

Installation Instructions Manual

Navien Air Conditioner NAE Series (24K/36K/48K/60K, R454B)

Model | NAE28V36-24K/36K
NAE28V60-48K/60K



ALWAYS read and follow this manual completely before using the Air conditioner. Save for future reference.

⚠ WARNING

FIRE OR EXPLOSION HAZARD

Improper installation, operation, or service can damage the Air conditioner, your home, and other property and can create hazards such as fire, burns, electric shock, and explosion, which can result in serious injury or death.

For use with R-454B indoor units only. Navien recommends installing only indoor and outdoor systems that are AHRI approved and compatible. Read the entire user guide before starting installation.

This appliance must be installed and serviced by a technician qualified under all local and national buildings codes.

Follow all safety codes. Wear safety glasses, protective clothing and work gloves. Use a quenching cloth for brazing operations. Have a dry powder or carbon dioxide fire extinguisher available. Read this manual thoroughly and follow all warnings or cautions contained in the literature and attached to the appliance. Refer to the latest version of your local building code and the National Electrical Code (NEC) NFPA 70. In Canada, refer to the latest version of the Canadian Electrical Code CSA 22.1.

Contents

Important Safety Information	3	6. Error codes	37
GENERAL	9	6.1 Alarm Table / Error Table	37
1. About the Air Conditioner	10	6.2 Troubleshooting Error Codes	40
1.1 Included Items	10	6.3 Minor Code	60
1.2 Dimensions	11	6.4 Care and Maintenance	62
1.3 Specifications	12	7. Appendixes	64
1.4 Components	13	7.1 Thermostat wiring	64
2. Installing the Air Conditioner	14	7.2 Wiring Diagram (NAE28V36)	65
2.1 Choosing an Installation Location	14	7.3 Wiring Diagram (NAE28V60)	66
2.2 Installing on a Solid, Mounting Pad	15	8. LIMITED WARRANTY NAVIEN, INC.	67
2.3 Tubing Visual Check	15		
2.4 Connecting the Refrigerant Line	16		
2.5 Installing the water line	17		
2.6 Installing a Buried-Lineset	17		
2.7 Vertical-line set	18		
2.8 Brazing the Refrigerant Line	20		
2.9 Connecting the Line Voltage	24		
2.10 Refrigerant Charging	25		
3. Operation the System and Setting the Dip Switch	28		
3.1 Setting the Dip Switch	28		
3.2 LCD Screen Display	29		
4. Installation Checklist	31		
5. Bluetooth Module	32		
5.1 Specifications	32		
5.2 Device Features	33		
5.3 Starting the Multikit App	34		
5.4 Installing the Bluetooth Module	34		
5.5 Troubleshooting	36		

Important Safety Information



The following Safety Alert Symbols are used in this manual. They are used to alert you to potential personal injury hazards. Obey all safety messages that follow this symbol to avoid possible serious injury or death. This Safety Alert Symbol precedes any safety message about risk of personal injury. It may also be accompanied by one of the following signal words.

If the information in these instructions is not followed exactly, a fire or explosion may result, causing property damage, personal injury or death.

DANGER

Indicates a hazardous situation that if not avoided will result in death or serious injury.

WARNING

Indicates a hazardous situation that if not avoided will result in death or serious injury.

CAUTION

Indicates a potentially hazardous situation that if not avoided could result in minor or moderate injury.

NOTICE

Indicates information considered important but not hazard-related (such as property damage).

DANGER

Electrical Shock Hazard



- Disconnect all remote electric power supplies before servicing. Follow proper locking/tagging procedures to ensure that the power supply will not be energized accidentally.
- After power is applied always wait a minimum of five minutes before working on any electrical. The five minutes is to allow voltage to dissipate from the inverter. Failure to do so may result in injury or death.
- If the supply cord is damaged, it must be replaced by the manufacturer, its service agent or similarly qualified persons in order to avoid a hazard.

WARNING

- This product may expose you to chemicals including lead and lead components, which are known to the State of California to cause cancer and, birth defects or other reproductive harm. For more information, please visit www.P65Warnings.ca.gov.

WARNING

- Installation and servicing of air conditioning equipment can be hazardous due to internal refrigerant pressure and live electrical components. Only trained and qualified service personnel should install, service and maintenance this equipment. Installation and service performed by unqualified persons can result in property damage, personal injury, or death.
- Product removal and recycling must be performed by a certified technician.
- The appliances are designed to be operated in outdoor area. If have to be installed indoor, the appliance shall be stored in a room without continuously operating open flames (for example an operating gas appliance) and ignition sources (for example an operating electric heater).
- The installation must comply with all provincial, state, and local codes as well as the National Electrical Code (U.S.) or Canadian Electrical Code (Canada).
- Before accessing the electrical terminals, all power circuits must be disconnected.

WARNING

The instructions shall state the substance of the following:

This appliance is not intended for use by persons (including children) with reduced physical, sensory or mental capabilities, or lack of experience and knowledge, unless they have been given supervision or instruction concerning use of the appliance by a person responsible for their safety. Children should be supervised to ensure that they do not play with the appliance.

WARNING

Refrigerant Oil

USE ONLY R-454B REFRIGERANT AND APPROVED COMPRESSOR OIL

- Attempting to repair central air-conditioning products may result in property damage, serious personal injury or death. Use only the service equipment approved for use with R-454B.
- This systems use POE oil (VG74, VG75 or equivalent), which can easily absorb moisture from the atmosphere. If the system is exposed to the atmosphere for more than 4 hours, the compressor oil must be changed.
- The filter drier must be replaced any time the refrigerant system is opened.

WARNING

Brazing required

- Brazing should only be done on refrigerant tubes that are open to the atmosphere or are properly exhausted.
- If using existing refrigerant lines, make sure that all joints are brazed, not soldered.

WARNING

- Do not use any means to accelerate the defrosting process or to clean, other than those recommended by the manufacturer.
- The appliance shall be stored in a room without continuously operating ignition sources (for example: open flames, an operating gas appliance or an operating electric heater.)
- Do not pierce or burn.
- Be aware that refrigerants may not contain an outdoor unit.

WARNING

Qualification of workers

Every working procedure like maintenance, service and repair operations that affects safety means shall only be carried out by competent persons. Examples for such working procedures are:

- Breaking into the refrigerating circuit;
- Opening of sealed components;
- Opening of ventilated enclosures.

WARNING

Checks to the area

Prior to beginning work on systems containing **FLAMMABLE REFRIGERANTS**, safety checks are necessary to ensure that the risk of ignition is minimized.

Work procedure

Work shall be undertaken under a controlled procedure so as to minimize the risk of a flammable gas or vapour being present while the work is being performed.

WARNING

When installing and repairing the system, comply with the following precautions prior to conducting work:

Contact a qualified installer, service provider, or distributor for information or assistance.

Qualified installers or agencies must use factory-approved kits or accessories when modifying this product.

Refer to the individual instructions packaged with the kits or accessories.

Have a dry powder or CO2 fire extinguisher available.

Work must be executed using a controlled procedure so as to minimize the risk of flammable gases or vapors while working.

All maintenance staff and others working in the local area must be instructed about the nature of the work being carried out. Work must not be done in confined spaces.

The area must be checked with an appropriate refrigerant detector prior to and during work, to ensure the technician is aware of potentially toxic or flammable substances. Ensure that the leak detection equipment being used is suitable for use with R-454B refrigerant, being non sparking, adequately sealed or intrinsically safe.

Any person carrying out work in relation to a refrigerant system which involves opening the sealed refrigerant system must use any sources of ignition in such a manner to eliminate any risk of fire or explosion. All possible ignition sources, including lit cigarettes, must be kept sufficiently far away from the places of installation, repair, removal and disposal, as refrigerant can possibly be released in the surrounding space. Prior to work taking place, the area around the equipment must be surveyed to make sure that there are no flammable hazards or ignition risks. "No Smoking" signs must be displayed.

WARNING

Ventilated area

- Ensure that the area is in the open or that it is adequately ventilated before opening the system or conducting any hot work. A degree of ventilation shall continue during the period that the work is carried out. The ventilation should safely disperse any refrigerant accidentally released and preferably expel it externally into the atmosphere.

WARNING

Checking the refrigerating equipment

- When electrical components are changed, they must be fit for the purpose and meet the correct specifications. At all times the manufacturer's maintenance and service guidelines must be followed. If in doubt, consult the manufacturer's technical department for assistance.
- Only appropriate tools designed for R454B A2L refrigerant should be used. For A2L refrigerants, non-sparking tools are required.
- The following checks must be applied to installations using flammable refrigerant.
 - The actual refrigerant charge is in accordance with the size of the room that the refrigerant containing components are installed in.
 - The ventilation machinery and outlets are operating adequately and are not obstructed.
 - The secondary circuit must be checked for the presence of refrigerant if a secondary refrigerating circuit is being used.
 - The markings on the equipment continue to be visible and legible. Markings and signs that are illegible must be corrected.
 - The refrigerating pipe or components are installed in a position where they are unlikely to be exposed to any substance that may corrode the refrigerant containing components, unless the components are constructed of materials that are inherently resistant to being corroded or are suitably protected against corrosion.
- Continuous air circulation required for proper functioning. Unit must be powered except for service.

WARNING

Checking to electrical devices.

- Repair and maintenance of electrical components must include initial safety checks and component inspection procedures. If a fault exists that could compromise safety, do not connect the electrical supply to the unit until it is satisfactorily dealt with. If the fault cannot be corrected immediately but it is necessary to continue operation, an adequate temporary solution should be used. This must be reported to the owner of the equipment so all parties are advised.
- Initial safety checks must include the following:
 - Discharging of capacitors: must be done in a safe manner to avoid possibility of sparking.
 - Ensuring no live electrical components or wiring is exposed while charging, recovering or purging the system.
 - There is continuity of earth grounding.

WARNING

Sealed electrical components must be replaced.

- During repairs to sealed components, all electrical supplies must be disconnected from the equipment being worked upon prior to any removal of sealed covers, etc. If it is absolutely necessary to have electricity supplied to the equipment during servicing, then a permanently operating form of leak detection must be located at the most critical point to warn of a potentially hazardous situation.
- Particular attention must be paid to the following to ensure that the casing is not altered in such a way that the level of protection is affected during work. Attention should be paid to not damaging cables, not creating excessive connections, avoiding the creation of terminals not made to the original specification, damaging seals, incorrect fitting of glands, etc.
- Ensure that the apparatus is mounted securely.
- Ensure that seals or sealing materials have not degraded to the point that they no longer prevent the ingress of flammable gases. Replacement parts must be in accordance with the manufacturer's specifications.

WARNING

Components must be intrinsically safe.

- Do not apply any permanent inductive or capacitance loads to the circuit without ensuring that this will not exceed the permissible voltage and current permitted for the equipment in use.
- Intrinsically safe components are the only types that can be worked on while live in the presence of a flammable atmosphere. The test apparatus shall be at the correct rating.
- Replace components only with parts specified by the manufacturer. Other parts may result in the ignition of refrigerant in the atmosphere from a leak.

WARNING

Cabling

All cables and wiring should be installed such that it is not subject to unnecessary wear, corrosion, excessive pressure, vibration, contact with sharp edges, or any other adverse environmental effects.

WARNING

This appliance is not intended for use by persons (including children) with reduced physical, sensory or mental capabilities, or lack of experience and knowledge, unless they have been given supervision or instruction concerning use of the appliance by a person responsible for their safety.

Children should be supervised to ensure that they do not play with the appliance.

WARNING

Detection of flammable refrigerants

- Under no circumstances should sources of ignition be used to search for or detect refrigerant leaks. Halide torches or any other detectors that use a naked flame must not be used.
- The following leak detection methods are deemed acceptable for all refrigerant systems:
 - Electronic leak detectors specifically designed to detect A2L refrigerants must be used to detect refrigerant leaks. (Detection equipment must be calibrated in a refrigerant-free area.) Ensure that the detector is not a potential source of ignition and is suitable for the refrigerant used. Leak detection equipment must be set to the LFL percentage of the refrigerant and must be calibrated to the refrigerant employed, and the appropriate percentage of gas (25 % maximum) is confirmed.
 - Leak detection fluids are also suitable for use with most refrigerants but the use of detergents containing chlorine must be avoided as the chlorine may react with the refrigerant and corrode the copper pipe-work.
 - Use either the bubble method or the fluorescent agent method for leak detection.
- If it is suspected that there is a leak, all flames must be removed/extinguished.
- If a refrigerant leak is found which requires brazing, all of the refrigerant must be recovered from the system, or isolated (by means of shut off valves) in a part of the system that is far from the leak. Removal of refrigerant must be performed according to specifications in the Removal and Evacuation section of this manual.
- Attention is drawn to the fact that additional transportation regulations may exist with respect to equipment containing flammable gas.
- The maximum number of pieces of equipment or the configuration of the equipment permitted to be transported together will be determined by the applicable transport regulations.
- Disposal of equipment using flammable refrigerants; See national regulations.
- The storage of the appliance should be in accordance with the applicable regulations or instructions, whichever is more stringent.

WARNING

Removal and evacuation

When opening the refrigerant system to make repairs or for any other purpose, the conventional procedures should be used. However, for flammable refrigerants it is important that the best practices be followed since flammable agents is a consideration.

The following procedure must be adhered to:

1. Safely remove refrigerant following local and national regulations
2. Evacuate.
3. Purge any tube or joint with an inert gas while brazing.
4. Continuously purge with inert gas when using the flame to open a refrigerant system.

The refrigerant charge must be recovered in appropriate recovery cylinders. The system must be purged with oxygen-free nitrogen to render the appliance safe for flammable refrigerants. This process might need to be repeated several times. Compressed air or oxygen must not be used for purging refrigerant systems.

For appliances containing flammable refrigerants, refrigerant purging must be achieved by breaking the vacuum in the system with oxygen-free nitrogen and continuing to fill it until the working pressure is achieved, then venting into the atmosphere, and finally pulling down to a vacuum. This process must be repeated until no refrigerant remains the system. When the final oxygen-free nitrogen charge is used, the system must be vented down to atmospheric pressure to enable work to take place.

The outlet for the vacuum pump must not be close to any potential ignition sources, and the area must be ventilated.

WARNING

Decommissioning

Before carrying out this procedure, it is essential that the technician is completely familiar with the equipment. It is recommended that all refrigerants have been safely removed. Prior to recovery, an oil and refrigerant sample should be taken for analysis if the recovered refrigerant is to be re-used. It is essential that electrical power is available before the task is commenced.

- Become familiar with the equipment and its operation.
- Isolate system electrically.
- Before attempting the procedure, ensure that:
 - Mechanical handling equipment is available, if required, for handling refrigerant cylinders.
 - All necessary personal protective equipment is available and being used correctly.
 - The recovery process is supervised at all times by a competent person.
 - Recovery equipment and cylinders conform to the appropriate standards.
- Pump down the refrigerant system, if possible.
- If it is not possible to use a vacuum, make a manifold so that the refrigerant can be removed from the various parts of the system.
- Make sure that the cylinder is situated on the scales before recovery takes place.
- Start the recovery machine and operate it in accordance with the instructions.
- Do not overfill cylinders (no more than an 80% of cylinder capacity).
- Do not exceed the maximum working pressure of the cylinder, even temporarily.
- When the cylinders have been filled correctly and the process has been completed, make sure that the cylinders and the equipment are removed from site promptly and all isolation valves on the equipment are closed.
- Recovered refrigerant must not be charged into another refrigerating system unless it has been cleaned and checked.

WARNING

Labelling

Equipment that has been de-commissioned and emptied of refrigerant must be labeled. The label must be dated and signed. Ensure that there are labels on the equipment stating the equipment contains flammable refrigerant.





WARNING

Recovery

- When removing refrigerant from a system, either for servicing or decommissioning, it is recommended that all refrigerant is safely reclaimed.
- When transferring refrigerant into cylinders, ensure that only appropriate refrigerant recovery cylinders are employed. Ensure that the correct number of cylinders for holding the whole system charge are available. All cylinders must be designated for the recovered refrigerant and labeled for that refrigerant. Cylinders must be complete with a pressure-relief valve and associated shut-off valves in good working order. Empty recovery cylinders must be flushed and, if possible, cooled before recovery occurs.
- The recovery equipment must be in good working order with a set of instructions concerning the equipment on hand, and the equipment must be suitable for the recovery of the flammable refrigerant. If in doubt, the manufacturer should be consulted. In addition, a set of calibrated weighing scales must be available and in good working order. Hoses must include leak-free couplings and be in good condition.
- The recovered refrigerant must be processed according to local regulations and be placed in the correct recovery cylinder, and the relevant waste transfer note attached. Do not mix refrigerants in recovery units and especially not in cylinders.
- If the compressors or compressor oils are to be removed, ensure that they have been flushed to an acceptable level to make certain that flammable refrigerant does not remain within the lubricant. The compressor body must not be heated by an open flame or other ignition sources to accelerate this process. When oil is drained from the system, it must be appropriately disposed of.

GENERAL

Marking and Instructions

 WARNING	This symbol denotes use of mildly flammable refrigerant.
 CAUTION	This symbol denotes that the operation manual should be read carefully.
 CAUTION	This symbol denotes that only service personnel should be handling the equipment in accordance with the installation manual.
 CAUTION	This symbol denotes that the information is available such as the operating manual or installation manual.

NOTICE

Effective January 1, 2023, all split-system and packaged Air conditioners must be installed pursuant to applicable the regional efficiency standards issued by the DOE.

All AHRI matched coils and air handler have a factory installed and calibrated TXV.

Units should only be installed with the approved indoor matches listed in the Air Conditioning, Heating and Refrigeration Institute (AHRI) Directory of Certified Products. Refer to <http://www.ahridirectory.org>.

This document is the property of the customer and should be kept with the unit. When you are finished, store this manual near the indoor unit for future reference.

GENERAL

- The maximum allowed elevation is 10,000 feet (3000 meters) above sea level.
- Locate unit away from windows, patios, decks, etc. where unit operation sounds may disturb customer.
- Ensure that the vapor and liquid tube diameters are appropriate for the unit's capacity.
- The maximum lineset length is 150 feet.
- The maximum vertical lift is 50 feet.







Move the equipment to its final location. Remove the carton, taking care not to damage the unit.

Inspecting the Equipment

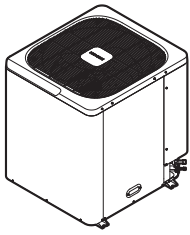
File a claim with the shipping company prior to installation if anything is missing or if the equipment was damaged. Locate the unit rating plate that contains information needed to properly install the unit. Check the rating Plate to be sure the unit matches the job specifications.

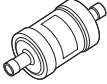
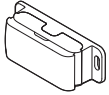
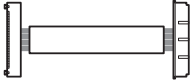
1. About the Air Conditioner

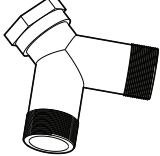
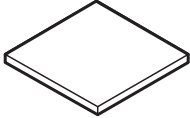
1.1 Included Items

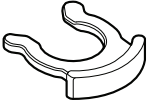
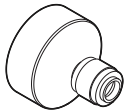
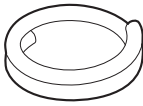
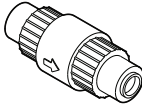
			
Air conditioner	Installation and Operation Manual Owner Manual	Filter Drier	Bluetooth Module (NAC-105M)
			
Bluetooth Cable*(4-wire, RS-485 connector)	Screw	Water Supply Hose	Outdoor Spigot Splitter
			
Pads	Hose clamp	Quick Connect Retaining Clip	Quick connect adapter
			
Drain Hose	Water Supply Strainer		

1.2 Dimensions

NAE28V36

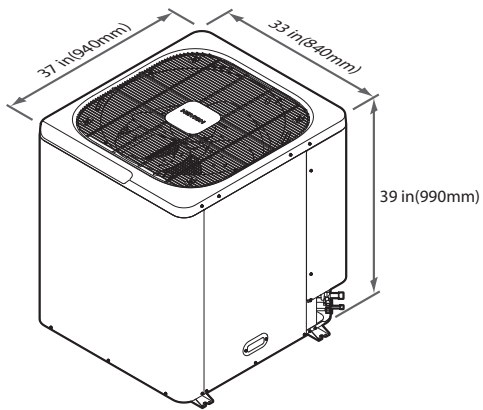

NAE28V60

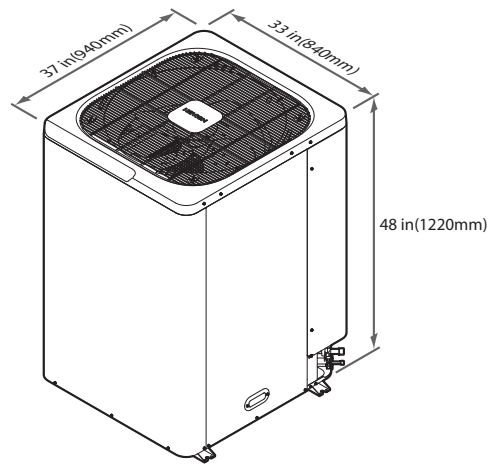

1.3 Specifications

The following table lists the specifications for the Air conditioner

	Unit	NAE28V36				NAE28V60			
Operating conditions	-	Hydro	Air	Hydro	Air	Hydro	Air	Hydro	Air
Cooling Capacity	BTU/h	24K		36K		48K		60K	
Maximum water usage	LPM	0.46	-	0.46	-	0.72	-	0.72	-
Sound Rating Level	dBA	63	73	63	73	67	75	67	75
Size(WxDxH)		33x37x39				33x37x48.6			
Compressor	type	Variable Speed Rotary							
	Maximum Rated current (MRC)	25				30			
Fan motor	Rated current (RLA)	1.0				1.0			
	Maximum Speed(rpm)	800				900			
	Motor H/P	1/3				1/3			
Refrigerant	Type	R454B							
	Charge lb (kg)	5.29 (2.4)				6.6 (3.0)			
Valve Connect	Vapor in O.D	3/4				7/8			
	Liquid in O.D	3/8							
Water Connect	Type	Fitting							
	Size	1/4"							
Drain hole size		18A							
Electrical Data	V -PH-HZ	230-1-60							
	Minimum Circuit Ampacity(MCA)	32.25				38.5			
	Max. Overcurrent Protection(A)	50				60			
	Min/Max Volts (V)	197/253							
Operating Temperature	Cooling Mode(°F)	55 – 126							

1.4 Components

The following diagram shows the key components of the AC

No.	Components
1	Rotary Compressor
2	High Pressure Sensor, Low Pressure Sensor
3	High Pressure Switch
4	Vapor Service Valve
5	Liquid Service Valve
6	Accumulator
7	Condenser
8	Motor
9	FAN Blade
10	Pre-filter

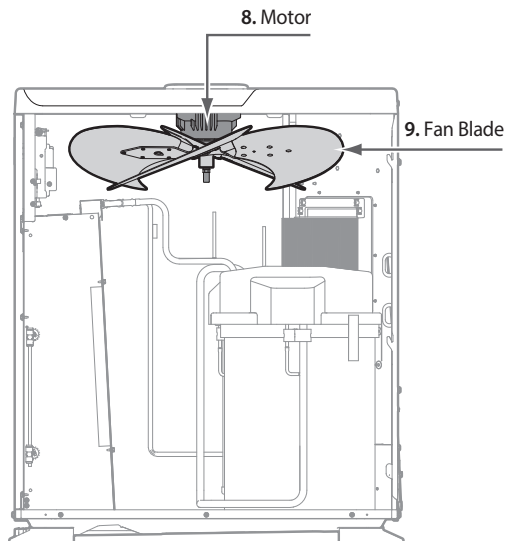
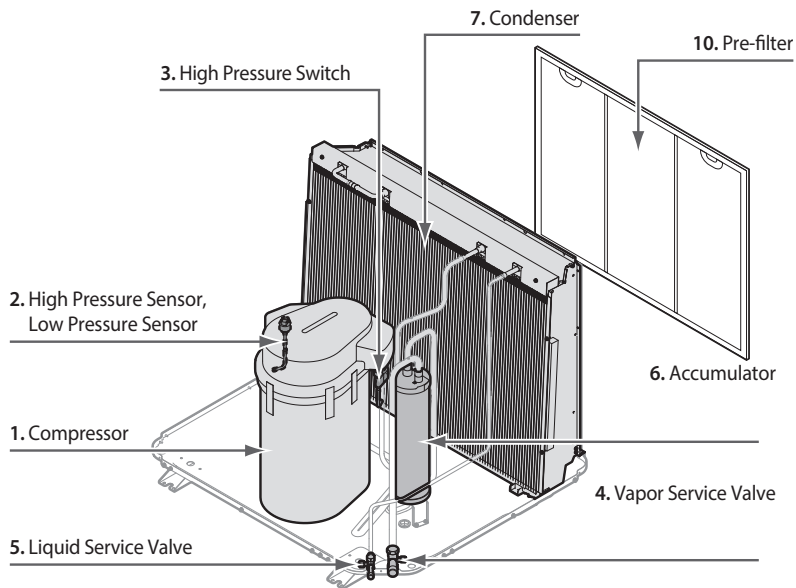

2. Installing the Air Conditioner

2.1 Choosing an Installation Location

Prepare the Unit for Installation

Check whether there is any damage and report any damage to the shipping company. Move to final location. Remove carton taking care not to damage unit.

Ensuring Adequate Space (Clearances)

When installing, allow sufficient clearance for airflow, wiring, refrigerant line set and service.

- Allow 24" (610 mm) clearance to service side of unit.
- Allow 48" (1220 mm) above unit.
- Maintain a distance of 24" (610 mm) between units or 18" (457 mm) if no overhang within 12 ft. (4 m).
- Locate the outdoor unit away from sleeping quarters to avoid disruptive noise.
- Allow 24" (610 mm) clearance to air inlet side of unit. (For maintenance of water piping modules and Condenser Coils)

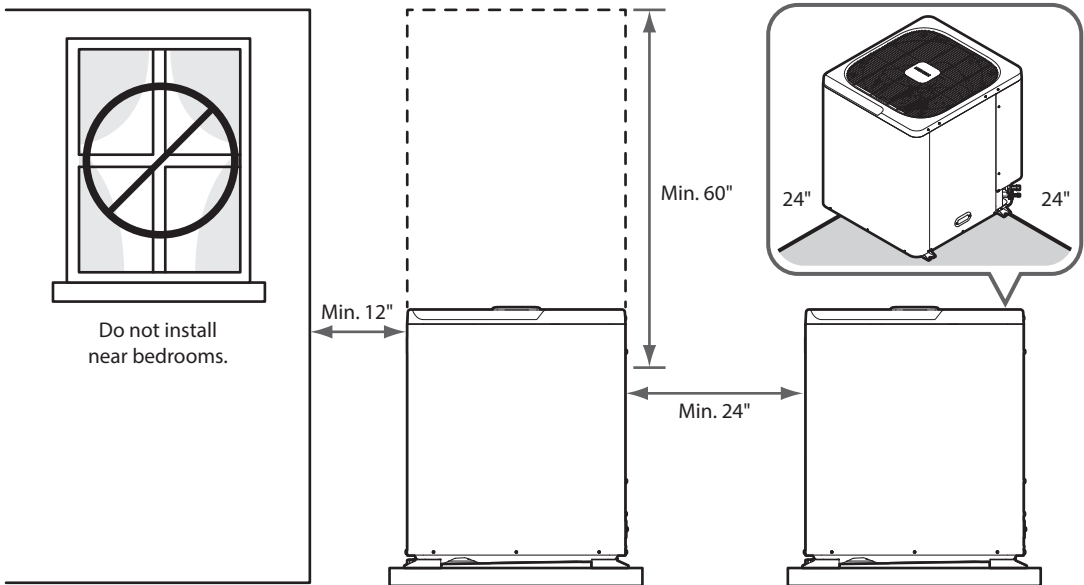

Location	Minimum Clearance Distance
Service Side	24" (610mm)
Above Unit	48" (1,220mm)
Between Units	24" (610mm)
Against Wall	12" (305mm)
Inlet Unit	24" (610mm)

- Position it so water, snow, or ice from the roof or eaves cannot fall directly on the unit.

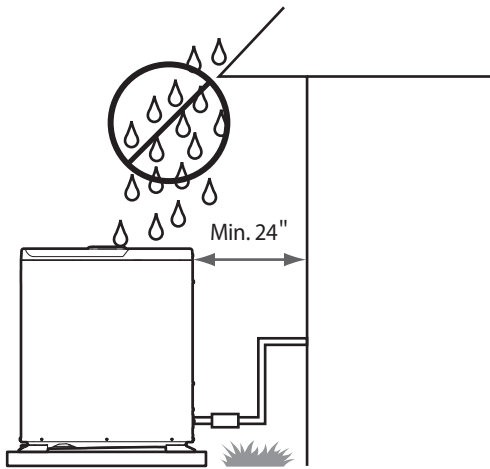

Corrosive Environments

Exposure to corrosive environment may shorten the service life of the unit, corrode metal parts, and/or negatively affect the unit's performance. Corrosive elements include but are not limited to:

- Seawater: sodium chloride, sodium hydroxide, sodium sulfate, and other compounds.
- Industrial/manufacturing plants: sulfur, chlorine, fluorine, fertilizers and various chemical pollutants.
- Supply water: copper, chlorine and other compounds.

If it is installed in an area that may be exposed to a corrosive environment, special attention should be paid to the placement and maintenance of the unit.

- Lawn sprinklers/hoses/waste water should not be sprayed directly on the outer panel of the unit for prolonged periods.
- In coastal areas: install the unit on the side away from the waterfront.
- Fences or shrubs can provide some shielding protection for the unit, but the minimum device clearance must still be maintained.
- Clean the outdoor coil and any exposed external surfaces once at least every one year or as necessary, depending on the conditions of the installation using only tap water.

2.2 Installing on a Solid, Mounting Pad

When installing the unit on a support pad (such as a concrete slab), consider the following:

- All sides of the pad must be at least 1-2 inches larger than the unit.
- The pad must be separated from any structure.
- Slab should have a slope tolerance away from the building of 1/4" per foot.
- The pad must be high enough above the ground for drainage.
- The location of the pad must comply with national, state and local regulations.
- Use the included rubber leveling pads to ensure the unit is level or slightly sloped towards the drain.

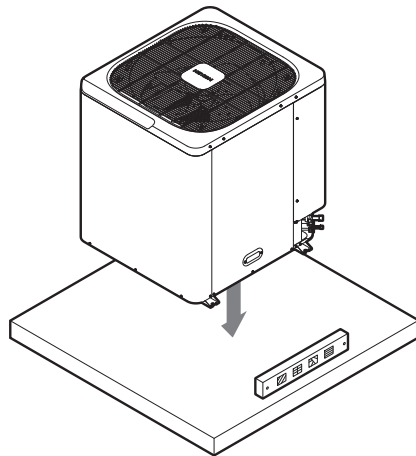

2.3 Tubing Visual Check

After setting the unit at the install location, check that the tubing in both the indoor and outdoor unit has not shifted during shipment. Ensure tubes are not rubbing against each other or any parts of the cabinet. Pay close attention to TXV feeder tubes, making sure wire ties on feeder tubes are secure and tight.

2.4 Connecting the Refrigerant Line

The piping material, routing, and installation must include protection from physical damage during operation and service while in compliance with national and local codes and standards for the installation site.

Outdoor units must be connected to the indoor section using field-supplied refrigerant grade copper tubing of the correct size and condition.

The suction line (larger of the two) must be entirely insulated.

Keep the line set tubing from coming in direct contact with the water pipes, ductwork, floor joists, wall studs, floors, or walls.

Do not suspend refrigerant tubing from joists and studs with a rigid wire or strap which comes in direct contact with any tubing.

When necessary, use hanger straps which are 1 in. (25 mm) wide and conform to the shape of the tubing insulation.

Ensure that the tubing insulation is pliable and completely surrounds the suction line.

Do not allow the copper suction and liquid line to come in direct contact with each other.

Run the refrigerant line set with as few bends as possible.

Model	Suction Line	Liquid Line
NAE28V36	3/4"	3/8"
NAE28V60	7/8"	3/8"

Secure the refrigerant line from the joists using isolators every 8 ft. Secure the Liquid Line directly to the Suction Line using tape, wire, or another appropriate method every 8ft.

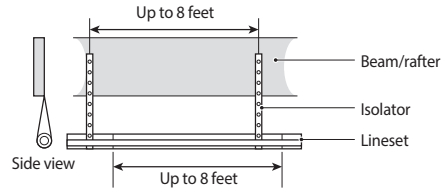

[Isolated from beam/rafter]

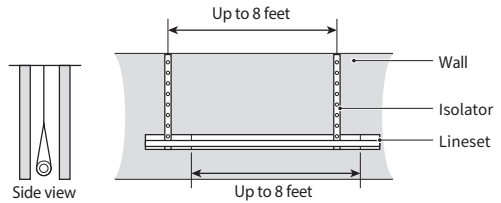

[Isolation on the wall]

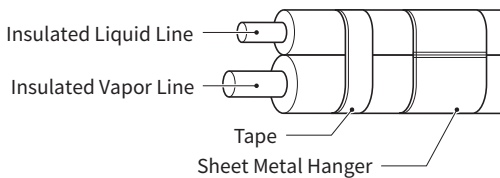
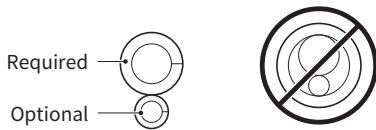

2.5 Installing the water line

2.5.1 Water supply line

1. The main water line to the product is connected to a water supply like an outdoor water spigot that ensures water pressure of 43 to 80 psi. (If water pressure is insufficient, install a pump.)
2. The main water supply distance from the product must be less than 33ft.
3. When connecting the water supply hose from the source to the unit, make sure it is fully inserted in to the supply fitting on the air conditioner.
4. After connecting the water supply hose, secure it with the supplied retaining clip to prevent it from coming off.
5. Connects to a single water tap exclusively for the product. (Do not use the water pipe connected to the product for any other purpose, such as car washing.)
6. Using a water supply that is pre-treated is recommended (Navien WEC or water softener).
7. Use the included water supply hose.

2.5.2 Drainage line

1. Connect the included drain hose to the Hydro AC drain.
2. Drain line must be installed without sharp bends or dents.
3. Install the drain line with a slope to ensure proper drainage.
4. Route the drain hose to a drain, lawn, or other location where drain water can be disposed.

2.6 Installing a Buried-Lineset

Use a PVC chase sealed at both ends with RTV or another pliable sealant.

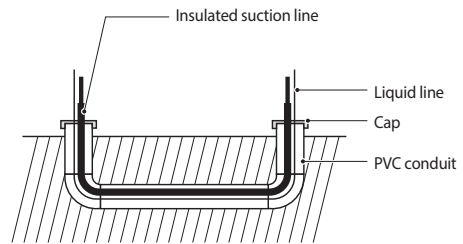

When passing refrigerant lines through a wall, seal the opening with RTV or another pliable silicon-based caulk.

Provisions must be made for the expansion and contraction of the line set.

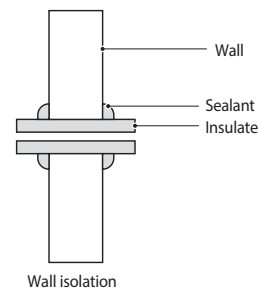

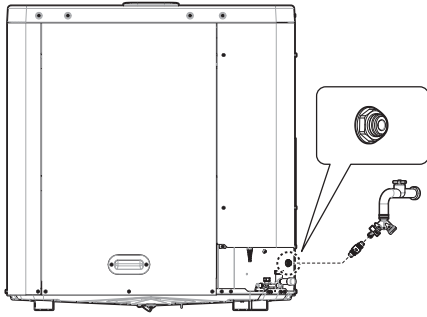

Water supply line

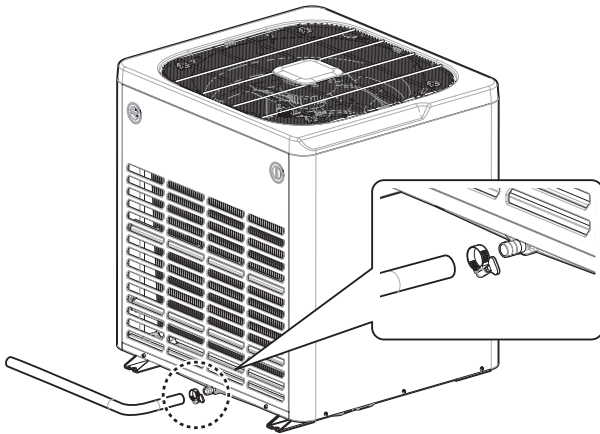

Drain line

2.7 Vertical-line set

Note that the length of the connecting line from the outdoor unit to the indoor unit cannot exceed 150 feet. If all long lines are horizontal, no additional measurements are required.

The vertical difference between the outdoor unit and indoor unit cannot exceed 50 feet. If there is a vertical height difference in a long line, it needs to be installed according to the following requirements.

Vertical Height Difference (h, ft.)	Description
$0 < h \leq 16.5$	No additional measurements are required
$16.5 < h \leq 33$	A suction line trap needs to be added in the middle of the height difference
$33 < h \leq 50$	Two suction line trap need to be added at an equal distance from each other in the height difference

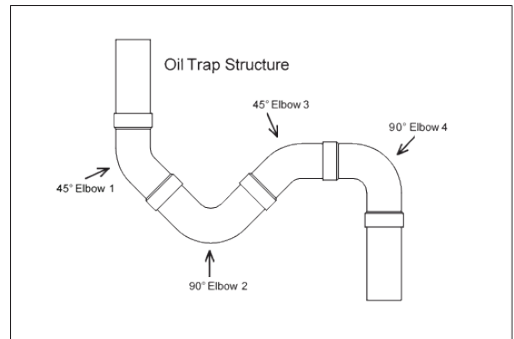

[Typical vertical suction trap configuration]

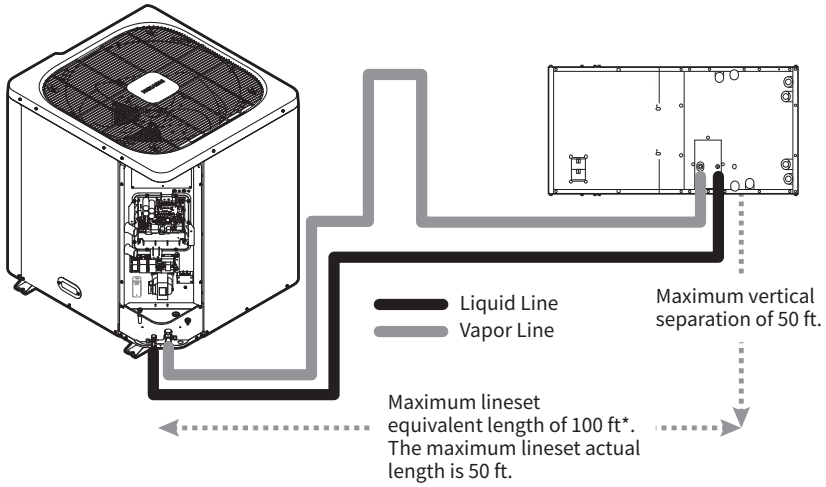

* Includes pressure losses of any elbow, bends, etc.

[Air Conditioner below Indoor Coil]

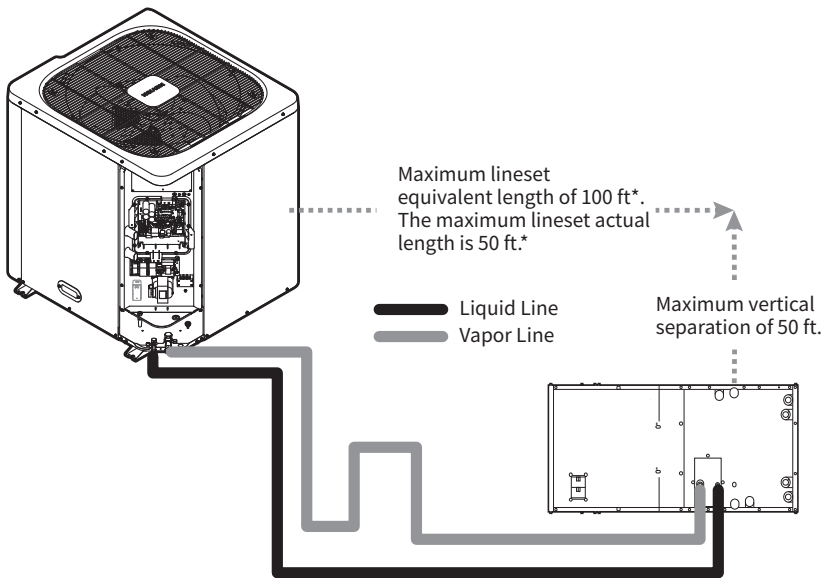

* Accounts for pressure losses of any elbow, bends, etc.

[Air Conditioner above Indoor Unit]

2.8 Brazing the Refrigerant Line

If the inside of refrigerant tubes or the indoor coil are opened to atmosphere, they must be evacuated to 500 microns to eliminate contamination and moisture.

Refrigerant pipe should be installed with the minimum length possible and practical for the application.

Piping should be protected from physical damage in operation and in service and be in compliance with national and local codes such as ASRHAЕ 15, ASHRAE 15.2, IAPMO Uniform Mechanical Code, ICC International Mechanical Code, or CSA B52.

All field joints shall be accessible for inspection prior to being covered or enclosed.

When installing the indoor and outdoor units at different elevations or levels, proper trapping must be used to prevent slugging or oil trapping, either of which can damage the system and shorten the service life of the equipment.

NOTICE

Service valves come from the factory closed and capped. Outdoor units are shipped with a refrigerant charge sealed in the unit. Leave the service valves closed until all other refrigerant system work is complete or the charge will be lost. Leave the plugs in place until line set tubing is ready to be inserted.

Reuse of the Existing Refrigerant Lines

If the existing line-set was used for any refrigerant other than what the unit is approved for, the appropriate recovery and flushing procedures must be performed. Flushing solution must be reclaimed in accordance with both national and local codes.

If reusing refrigerant line-set that the unit has been removed from it must be properly flushed and kept clean and free of foreign substances. The following precautions should be taken for the retrofit application that will use the existing refrigerant line-set:

- Make sure the refrigerant line size is correct.
- Make sure the refrigerant line has been properly flushed and is free of leaks, acid or oil

Brazing Connections

Remove caps or plugs. Clean line set tube ends with an emery cloth or steel brush. Remove any grit or debris and prevent it from entering the tube or fitting being cleaned. Connect vapor tube to fitting on outdoor unit vapor service valves. Connect liquid tubing to fitting on liquid service valve. Use only refrigerant grade copper tubing.

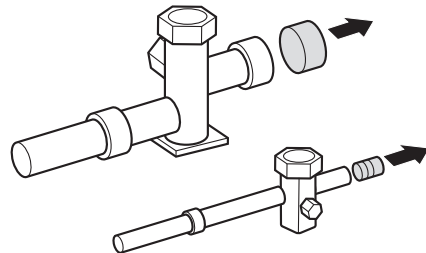

Purging Nitrogen

For the liquid and vapor service valves, be sure to remove the valve core from the Schrader port on the service valves BEFORE brazing. This helps prevent heat damage to the valve seals and helps expedite processing. Replace the valve cores when brazing is complete and the valves have completely cooled down.

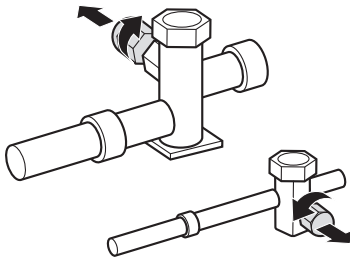

To prevent harmful oxidation from forming inside the tubing while brazing, purge the lineset with nitrogen while brazing. Let the regulated dry nitrogen flow (at 1 to 2 psig) through the refrigeration gauge set into the valve stem port connection on the liquid service valve and out of the vapor valve stem port on the manifold gauge set connections while brazing the line-set and filter drier. Apply heat absorbing paste or the heat sink product between the service valve and a braze joint. Wrap the service valves with a heat sink material such as a wet cloth. After wrapping the service valves with a wet cloth, the line-set can be brazed to the service valve using either the silver bearing or non-silver bearing brazing material.

Braze joints using a sil-fos or phos-copper alloy and continue dry nitrogen purging during brazing.

NOTICE

- Do not employ a soft solder (materials which melt below 800°F (427°C)).
- Do not remove the wet cloth until all brazing is completed.

⚠ WARNING

Fire, Explosion and Personal Safety hazard.

- Do not use oxygen to pressurize or purge refrigerant lines. Oxygen can react when exposed to sparks and cause fires or explosions.

Brazing the Refrigerant Line and the Filter Drier

All units are supplied with a filter drier. Braze the filter drier in the liquid line, taking care not to push the refrigerant line too hard through the stop in the filter drier (doing so will damage the filter). The filter drier can be installed adjacent to the indoor or outdoor unit.

Braze the refrigerant lines to the service valves. Continue the dry nitrogen purge.

While brazing the lineset to the service valves make sure not to overheat, burn or damage the outdoor ambient sensor which is located in the same area as the service valves.

NOTICE

- Do not remove the wet rag until all brazing is completed.
- Remove the wet cloth before stopping the dry nitrogen purge.

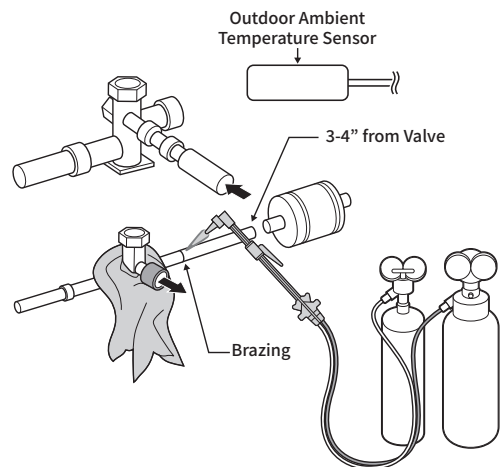

When replacing the filter drier, refer to Product Replacement Parts List for the appropriate part number. You can purchase replacement filter driers from your distributor or branch.

Outdoor unit Connected to Factory Approved R-454B Indoor Unit

When outdoor unit is connected to AHRI matched R-454B indoor unit, the outdoor unit contains the appropriate system refrigerant charge for operation with an AHRI rated indoor unit when connected by 15ft. of field-supplied or factory line-set tubing and the factory supplied filter drier.

Crimping Line Connections

If using mechanical or crimp-type line-set connections, follow the crimp tool manufacturer's instructions.

Note If the use of mechanical fittings leads to the failure of the fittings or unit, such failure will not be covered under the unit's limited warranty.

Pressure Test for Gross Leaks

The line set and indoor coil should be pressure tested with an inert gas such as nitrogen. Pressurized the system with the inert gas to the Low Side Test Pressure listed on the outdoor unit rating plate.

Perform a pressure check of the unit with a nitrogen charge of about 200 psi.

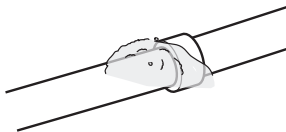
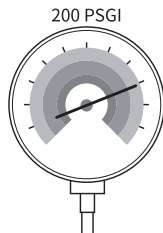

Use an approved leak check fluid that will not interfere with your electronic leak detector on each braze joint to check for gross leaks.

The nitrogen holding charge must NOT decrease in pressure for 1 hours, as indicated by the test gauge.

Leak Check

The deep vacuum method requires a vacuum pump capable of creating a 500micron vacuum and a vacuum gage capable of accurately measuring the vacuum's depth. The deep vacuum method is the most positive way of assuring a system is free of air and non-condensables. A tight dry system will hold a vacuum of 1000microns after approximately 7 minutes.

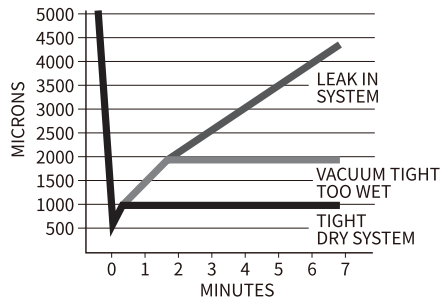
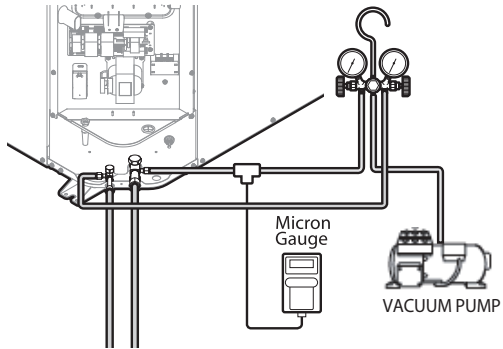

Evacuation

Use a electronic vacuum gauge that is calibrated in microns.

1. Connect the manifold gauge set to the service valve ports as follows:
 - Low pressure gauge to suction line service valve
 - High Pressure gauge to liquid line service valve
2. Connect the micron gauge and the vacuum pump (with the vacuum gauge) to the center port of the manifold gauge set.
3. Open both the manifold valves and turn the vacuum pump on.
 - Evacuate until the micron gauge reading is no higher than 350 microns, then close off the valve to the vacuum pump.
4. Observe the micron gauge. Evacuation is complete, if the micron gauge does not rise above 500microns in 1 minute and 1500microns in 10 minutes.
 - Once evacuation is complete, turn off the vacuum pump and micron gauge, and close the valves on the manifold gauge set.

Opening the Service Valve

⚠ WARNING

- Before opening the service valves, the leak inspection and evacuation must be completed.
- The suction service valve must be opened before the liquid service valve.
- When opening the liquid line service valve, extreme caution should be exercised. Failure to observe this warning will result in the release of system pressure, which could result in personal injury or property damage.

⚠ WARNING

EXPLOSION HAZARD

Never use air or any gas containing oxygen for leak testing or operating refrigerant compressors. Never allow compressor suction pressure to occur in a vacuum with service valves closed.

NOTICE

Do not apply excessive force, and do not use power tools for actuating valves.

1. Remove the valve cover from the suction service valve and the liquid service valve.
2. Insert the hex wrench into the valve stem completely and **slowly** back out counterclockwise until the valve stem just touches the bead (about 5 turns.)
3. After the suction service valve is fully opened replace the valve stem caps to prevent leakage. Tighten it with your fingers and turn it for another 1/6 turn using the appropriately sized wrench.
4. Repeat the same steps for the liquid line service valve.

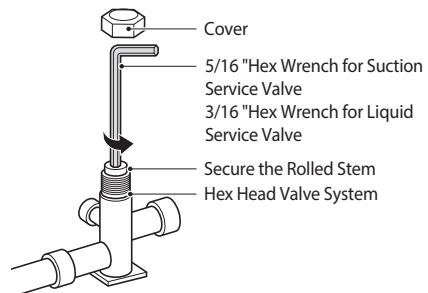

2.9 Connecting the Line Voltage

⚠ WARNING

ELECTRICAL SHOCK HAZARD.

- Before installing, modifying, or servicing the system, the main electrical disconnect switch must be in the OFF position. There may be more than one disconnect switch. Lock out and tag switch with a suitable warning label.
- The unit must be properly grounded in accordance with national and local codes.
- Before connecting the power supply, grounding is essential.

Be sure the field wiring complies with local and national fire, safety, and electrical codes, and the voltage to the system is within limits shown on the unit rating plate. Reference voltage on unit rating plate for the recommended circuit protection device.

Operation of the unit on improper line voltage will affect unit reliability and the overall service life of the equipment. See unit the rating plate. Do not install the unit in a place where the voltage may fluctuate above or below permissible limits.

Use copper wire only between the disconnect switch and unit.

Note Install a branch circuit disconnect of adequate size per NEC, to handle the unit's starting current. Locate the disconnect within sight of the unit and have it readily accessible, per Section 440-14 of the NEC. Refer to Product Data for the breaker sizing.

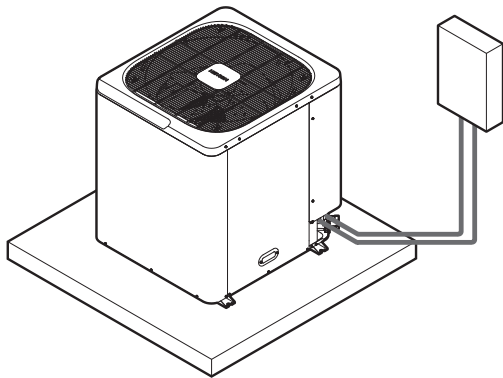

Route Ground and Power Wires, remove the access panel to gain access to unit wiring. Extend the wires from the disconnect through the power wiring hole provide and into the unit control box.

Remove the terminal strip protective cover and connect the ground and connect power wires to L1 and L2 as marked. The power supply wiring must comply with national, state and local regulations. Follow the unit wiring diagram located on the back side of the control box access panel, refer to "7.3 Wiring Diagram" on page 66.

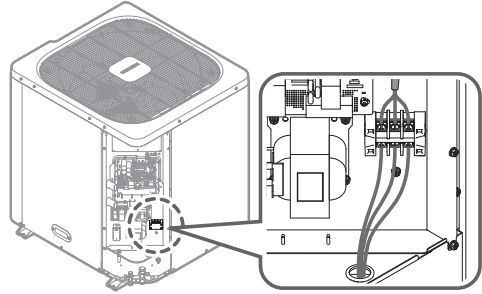

⚠ WARNING

Live Electrical Parts

- During the installation, testing, maintenance and troubleshooting of this product, it may be necessary to use live electrical parts. Failure to observe all electrical safety precautions when exposed to live electrical parts may result in death or serious injury.
- The high-voltage power supply must match the nameplate of the unit.

Control Wiring

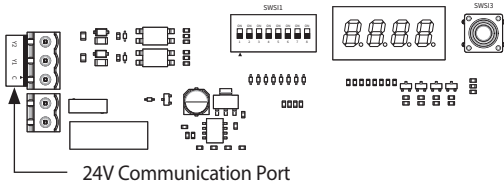

Route the 24 V control wires through the control wiring grommet and connect the leads to the low voltage terminal strip. Refer to “7.1 Thermostat Wiring Diagram” on page 64 for specific unit combinations.

Use solid core no. 18 AWG color-coded, insulated (35°C minimum) wire.

Note If the thermostat wire is longer than 100ft. (31m) unit, use no. 16 AWG color-coded thermostat wire to avoid excessive voltage drop.

Use the furnace transformer, air handler transformer, or accessory transformer for control power, 24 V/40 VA minimum. Make sure the available VA is adequate to support the total low voltage load.

Final Wiring Check

Referring to the unit nameplate, size the circuit, ensuring that the appropriate breaker is installed. Install a disconnect.

NOTICE

Check the factory wiring and field wire connections to ensure the terminations are secured properly. Check the wire routing to ensure that the wires are not in contact with the tubing, sheet metal, etc.

2.10 Refrigerant Charging

2.10.1 System Charge

Check the outdoor ambient temperature. Subcooling (cooling mode) is the only recommended charging method when the outdoor ambient temperature is higher than 55°F. For outdoor ambient temperature below 55°F, use the weigh-in charging method.

2.10.2 Refrigerant Charging: Subcooling Method

The only mode approved for verifying system charging is in “forced cooling mode”.

The outdoor temperature must be between 55°F and 120°F, and the indoor temperature should be between 68°F and 89°F. (The recommended indoor temperatures are between 70°F and 80°F.)

1. After powering the unit find SW1, on Dip SW1, Press the button for 3 seconds to enter Test Run Setting mode.
2. Create a cooling demand thermostat. (Y1 or Y1+Y2 signal conditions)
3. After initial startup of the outdoor unit, the fan and compressor will run at the speed determined for each model. While in Test Run Setting mode, water spray will be deactivated as charging must be done without water spray.
4. The current degree of subcooling is displayed on the display of the outdoor unit control panel.
5. After 5 minutes of operation, slowly fill the unit with refrigerant and, continuously monitor whether the subcooling value is within the range specified for the specific model.
6. After 20 minutes of operation, if the subcooling is within the specified range and remains stable for more than 5 seconds, the value on the display will blink.

2.10.3 Refrigerant Charging: Weigh-in method

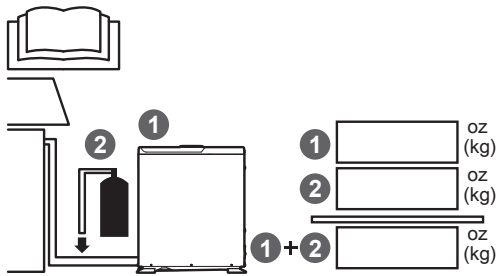

Use the weigh-in method anytime a system is being replaced and Unit should be operating to perform charge. At the equipment site or the operating conditions (indoor/outdoor temperatures) are not within the range for verification using the subcooling charging method.

The factory charge in the outdoor unit is sufficient for 15 ft of standard lineset. Additional 0.74 oz/ft refrigerant is needed when the length of the lineset is more than 15 ft.

New Installations — Calculating an additional charge for lineset greater than 15 ft.

1. Total length of line (ft) = _____(a)
2. Standard line setup (ft) = 15 (b)
3. (a) minus (b) = _____(c)
4. Refrigerant multiplier = 0.74 oz/ft (d)
5. Additional refrigerant quantity (c*d) = _____(e)*

* If the lineset is less than 15 feet, e=0

Sealed-System Repairs — Calculating the total system charge.

1. Total length of line (ft) = _____(a)
2. Standard line setup (ft) = 15 (b)
3. (a) minus (b) = _____(c)
4. Refrigerant multiplier = 0.74 oz/ft (d)
5. Additional refrigerant quantity (c*d) = _____(e)*
6. Factory filling quantity (nameplate) = _____(f)
7. Total system charge (e + f) = _____

* If the lineset is less than 15 feet, e = 0

When the weigh-in method is used, verify subcooling at a later time when ambient temperature exceeds 68°F.

NOTICE

In addition to conventional charging procedures, the following requirements shall be followed.

- Ensure that contamination of different refrigerants does not occur when using charging equipment.

Hoses or lines shall be as short as possible to minimize the amount of refrigerant contained in them.

- Cylinders shall be kept in an appropriate position according to the instructions.
- Ensure that the REFRIGERATING SYSTEM is grounded prior to charging the system with refrigerant.
- Extreme care shall be taken not to over charge the refrigerating system.

Subcooling – Ambient Temperature and Air conditioner Capacity						
Subcooling(°F)		Ambient Temperature(°F)				
		68~77	77~86	86~95	95~104	104~113
Model	2Ton	15±2	15±2	15±2	15±2	15±2
	3Ton	15±2	15±2	15±2	15±2	15±2
	4Ton	15±2	15±2	15±2	15±2	14±2
	5Ton	15±2	15±2	15±2	15±2	14±2

Subcooling – Liquid Line Temperature and Gauge Pressure								
Liquid Line Temp (°F)	Subcooling Value(°F)							
	11	12	13	14	15	16	17	18
	High Side Gauge Pressure (PSI)							
55	178	181	184	187	191	194	197	200
60	194	197	200	203	207	210	213	217
65	210	213	217	220	223	227	230	234
70	227	230	234	238	241	245	249	252
75	245	249	252	256	260	264	268	272
80	264	268	272	276	280	284	288	292
85	284	288	292	297	301	305	309	314
90	305	309	314	318	323	327	332	337
95	327	332	337	341	346	351	355	360
100	351	355	360	365	370	375	380	385
105	375	380	385	391	396	401	406	412
110	401	406	412	417	422	428	434	439
115	428	434	439	445	451	456	462	468
120	456	462	468	474	480	486	492	498
125	486	492	498	504	511	517	524	530

3. Operation the System and Setting the Dip Switch

3.1 Setting the Dip Switch

Setting the Dip Switch function

Function settings are set by checking Dip switches 1 to 4P.

Setting	Dip 1	Dip 2	Dip 3	Dip 4	Note
Refrigerant charging settings	ON	OFF	OFF	OFF	
Enter the service menu	OFF	ON	OFF	OFF	
Error reset	OFF	OFF	OFF	OFF	

* After setting each DIP switch, press the TACT switch for 3 seconds to enter.

Setting the Dip Switch Capacity

Capacity and Mode settings are set by checking Dip switches 5P to 8P.

Setting	Dip 5	Dip 6	Note
Capacity	OFF	OFF	24 kBTU/h
	ON	OFF	36 kBTU/h
	OFF	ON	48 kBTU/h
	ON	ON	60 kBTU/h
Setting	Dip 7	Dip 8	Note
Cooling Mode	OFF	OFF	Normal mode (default)
	ON	OFF	Mild mode
	OFF	ON	Comfort mode
	ON	ON	Normal mode

- 1) Normal mode : Cooling mode controlled by the normal compressor operating speed.
- 2) Mild mode : An operating mode that controls the compressor speed so that the lowest power consumption is achieved per unit operating hour.
- 3) Comfort mode : Among the cooling modes, this is the mode with the highest cooling and dehumidifying capacities.

* Cooling and Dehumidifying capacity : Mild ≤ Normal < Comfort

* Power consumption per unit operating hour : Mild ≤ Normal < Comfort



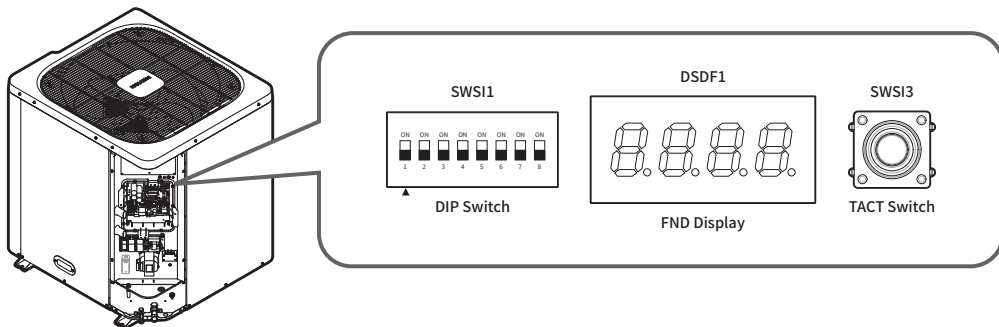





* This may vary depending on external environmental conditions.







3.2 LCD Screen Display

Normal operation

When an error occurs, after the issue has been identified and corrected perform an error reset (refer to 3.1)







Status Main	SEG Display	Description
When an error code occurs		When an outdoor unit error is detected, an error code is displayed State : Blinking
When an alarm code occurs		When an outdoor unit alarm is detected, an alarm code is displayed State : Blinking
During initialization		When power is supplied, the firmware version is displayed State : Blinking
During normal operation		Displays heat pump STATE State : Solid
When error is reset		Error Reset Release after 3 seconds of flashing
When a minor code occurs		A minor code is generated when no product error or alarm is displayed State : Blinking
When entering smart diagnostic mode		Smart diagnostic State : Solid
When entering service mode		Service mode operation State : Solid

Refrigerant Charging/Display

Display	Description
	<ul style="list-style-type: none"> Continually displays subcooling temperature After 20 minutes, the system calculates the subcooling temperature based on product capacity table (refer to 2.10). The display blinks if it is determined to be in the target subcooling range.
  	<ul style="list-style-type: none"> When the outside air temperature exceeds 120°F, [HI] will appear on the SEG display When the outside air temperature falls below 55°F, [LO] will appear on the SEG display When the Y1/Y2 signals are de-energized, [TH] will appear on the SEG display. When [HI]/[LO]/[TH] is determined, the display flashes for 3 seconds and then the operation is turned off.

Service Menu

Enter the service menu through the Dip switch settings (with Dip switch 2 turned on) and Press the SW_TACT button for 3 seconds to enter. See drawing on the page 28.

Standard display	Service Menu	Operation Menu
		
<ul style="list-style-type: none"> Press and hold SW_TACT button for 3 seconds to enter the service menu. 	<ul style="list-style-type: none"> Pump Down Setting Menu When the above state is displayed, press and hold SW_TACT button for 3 seconds to enter the Operation Menu - Pump Down 	<ul style="list-style-type: none"> Pump Down Operation Menu The pump down operation continues until the menu is deactivated by holding the SW_TACT button for 3 seconds.
		
	<ul style="list-style-type: none"> Forced Oil Recovery Setting Menu When the above state is displayed, press the SW_TACT button (3 sec) to enter the Operation Menu - Forced Oil Recovery 	<ul style="list-style-type: none"> Forced Oil Recovery Setting Menu Forced Oil Recovery is configured and the unit will exit Service Menu after blinking for 3 seconds.
		
	<ul style="list-style-type: none"> Service Menu Exit When the above state is displayed, press the SW_TACT button (3 sec) to exit the Service Menu and return to the standard display 	

4. Installation Checklist

After installing the Air Conditioner and indoor unit, review the following checklist. You should be able to answer "Yes" to all of the items on the checklist. If not, review the appropriate sections to complete the installation. To troubleshoot any operational problems refer to section "6. Troubleshooting Error Codes" on page 37.

If you have additional questions or need assistance with installation, contact Technical Support at 1-800-519-8794 or 1-949-420-0420, or refer to the technical support section of Navien's website (www.navieninc.com)

Surrounding Environment Checklist	Yes	No
Is the outdoor fan clear of any obstructions?		
Are the sides of the unit clear of all obstructions to airflow?		
Is the drain of the outdoor unit clear and unobstructed?		

Installation Checklist	Yes	No
Locate and level the unit.		
Check for proper wire size and fuse/circuit breaker. Consult local codes for the recommended wire size and the manual for proper fuse / circuit breaker.		
With the power turned off and locked out make sure all wiring connections are tight and properly secured, with the power turned back on check the incoming voltage and operating current are within specified limits. And the voltage and operating current are within the limits.		
All refrigerant lines are isolated, secured, and not in direct contact with each other or the structure.		
Check all braze connections for leaks. Record the additional refrigerant weight on a label next to the unit nameplate.		
Water is spraying from the nozzle.		
Drain line installed (no leaks from the drain adapter, adequate slope for water to drain out of the unit)		
Purge dry nitrogen while brazing		
Properly installed filter drier		
Evacuation to less than 500 microns for 1 min		
Target subcooling verified		

5. Bluetooth Module

5.1 Specifications

The Following table lists the specifications for the Bluetooth module.

Items	Description
Model	NAC-10SM
App	Navien Multikit App
Connection	RS-485, Bluetooth
Installation Mode	Charge Unit
Operation Ambient Temperature	-4 – 104°F
Bluetooth	<ul style="list-style-type: none">• Bluetooth V5.0• Frequency Range: 2,402-2,480 MHz• Channel: 40 channels for Bluetooth DTS• Max. transmit power: 7.544 dBm
Key Features	<ul style="list-style-type: none">• Accurate diagnostics• Check product information and error log• Technical graph: Visually check the product's status data• Monitoring(P&ID): Easily check each sensor's data on the product
Installation Location	Mounted in PCB

5.2 Device Features

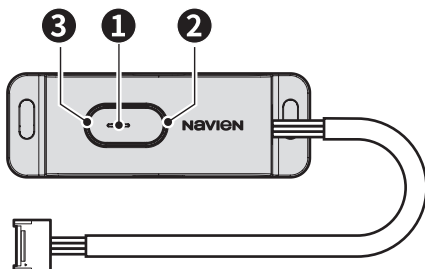

Part Name	Mode	Description	Operation	LED (Bluetooth / Wi-fi)
Button(1)	Boot Mode	Displays that module is booting up after initial power applied.	No button function	White LED on
	Standby Mode	Entering standby after initial power application	Press the button briefly to enter pairing mode.	LED off
	Pair Mode	Pairing with app via Bluetooth communication action	Long press of the button releases the pairing mode and enters standby mode.	Bluetooth LED (3) → Blinking blue LED
	Operation Mode	Bluetooth communication with app	Long press of the button releases the operation mode and enters standby mode.	Bluetooth LED (3) → Blue LED on
	Bluetooth module FOTA	When registering new F/W of Bluetooth module in app, FOTA proceeds	No button function	<ul style="list-style-type: none"> Bluetooth LED (3) → Blinking Blue LED Wi-Fi LED (2) → Blinking green LED
	Unit FOTA	When registering Unit's new F/W in APP, proceed with Unit's FOTA		
	Abnormal Mode	Error occurred	Long press of the button release the error and enters standby mode.	LED blinks red every 3 seconds

* FOTA: It is a form technology that receives firmware used in various equipment over the wireless network. (Used to perform system updates such as bugs, patches, adding new functions, operation system, etc.)

5.3 Starting the Multikit App

Download the Multikit app by searching “Navien Multikit” in the Google Play Store or Apple App Store. Once the download is complete, start the app.



[Navien Multikit App]

Note

Multikit app is used to interface with module. The Multikit app is designed to be used by contractors. It is not a consumer user app. For contractors, please refer to the unit information that can be checked through the Multikit app as shown in the table below.

Unit Information (Items contractors can check with the Multikit app)
NAE series A/C
<ul style="list-style-type: none">• Status values• Error history• Charge unit mode• Update to latest firmware• Smart diagnosis and Report issuance

For more information about the Multikit app, check the manual inside the app.

5.4 Installing the Bluetooth Module

Before starting installation, open the packaging and ensure that all items have been provided. Refer to “1.1 Included Items” on page 10.

5.4.1 Installing on the AC

1. Remove the electrical access cover from the AC.
2. Locate the wiring connection on the left side of the AC PCB.
3. Locate the screw holes on both sides on the bottom of the PCB.
4. Screw the Bluetooth module into two provided mounting holes as shown below using the provided screws.

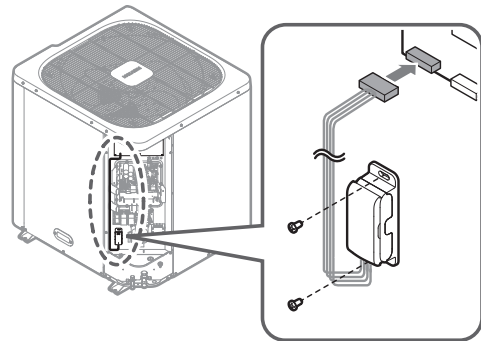

5. Connect the Bluetooth module’s RS-485 connector cable to the extension wires connected to the CNCM7 of the Air Conditioner control board.
6. Place the electrical access cover back on the Air Conditioner to enclose the PCB and Bluetooth module.

Note

The RS-485 connectors is already connected to the Bluetooth module.

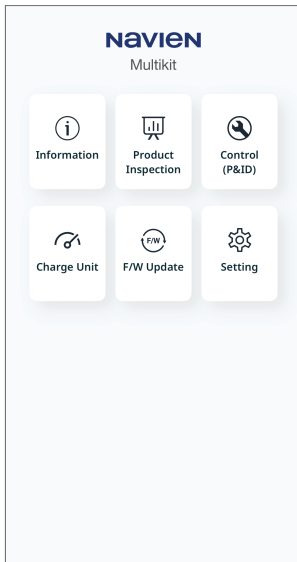

[Hydro A/C_Main page]

5.4.2 Pairing the Bluetooth Module with the Unit

NOTICE

To pair the Bluetooth module with the AC, Bluetooth on the smart device that will use the Multikit app must be turned on.

1. Start the Multikit app.
2. Select the model to connect from the 'select a Model' screen.
3. Press the Bluetooth module's pairing button briefly.
4. Once the Bluetooth connection is completed, the features available in the app will be displayed.

Note After the connection has been successfully made, the connected model information can be found in the information Tab. Detailed app screen images and menu items are provide in the app manual.

5.5 Troubleshooting

Items	Situation	Display LED	Solution
Module	The Bluetooth module is not turning on.	-	<ul style="list-style-type: none"> • Check the RS-485 connector. If the connector is not connected properly, reconnect it. • If the error continues to occur, replace the IoT module.
	When communication with the Wi-Fi module is interrupted for 30 seconds in a row.	LED red light	Press and hold the pairing button to release it.
Module, Device	When in operation mode, the device loses communication for 30 seconds in a row.	LED blinks red every 3 seconds	Press and hold the pairing button to release it.
Module, App	Bluetooth module and app are not connected properly.	-	<ul style="list-style-type: none"> • Restart pairing mode on the IoT module. • If the error continues to occur, replace the IoT module
App	<ul style="list-style-type: none"> • If there is no data displayed • If there is no data displayed on the graph • Data has stopped being displayed in monitoring (P&ID) 	-	<p>There are communication issues between the heat pump and IoT module.</p> <ul style="list-style-type: none"> • Check the RS-485 connector. If the connector is not connected properly, reconnect it. • Check for the cable damage. If the cable is damaged, replace it.

6. Error codes

6.1 Alarm Table / Error Table

Category	Alarm Code	Alarm Name	Reset
Cycle	251	PD protection operation	A
	252	PS protection operation	A
	253	TD protection operation	A
	254	CR protection operation	A
	255	CUR protection operation	A
	256	HEATSINK protection operation	A
	257	Compressor temperature abnormal	A
	258	TS protection operation	A
	259	Superheat protection operation	A
	260	HPS protection operation	A
Inverter	851	TRIP(Major) : Communication Error	A
	852	TRIP(Major) : Comp current sensor error	A
	853	TRIP(Major) : DC Link sensor error	A
	854	TRIP(Major) : PFCM current A error	A
	855	TRIP(Major) : PFCM current B error	A
	856	TRIP(Major) : Input voltage sensor error	A
	857	TRIP(Major) : Software comp over current	A
	858	TRIP(Major) : Over current with comp current limit	A
	859	TRIP(Major) : Over current with ID current limit	A
	860	TRIP(Major) : Hardware comp over current	A
	861	TRIP(Major) : PFC over current	A
	862	TRIP(Major) : Estimator fault	A
	863	TRIP(Major) : Comp starting error	A
	864	TRIP(Major) : Wire miss	A
	865	TRIP(Major) : Heatsink over temp	A
	866	TRIP(Major) : DC under voltage	A
	867	TRIP(Major) : DC over voltage	A
	868	TRIP(Major) : AC under voltage	A
	869	TRIP(Major) : AC over voltage	A
	870	TRIP(Major) : PFC unbalanced current	A
871	TRIP(Major) : Fan motor error 5min	A	
872	TRIP(Major) : Discharge FET error	A	
873	TRIP(Major) : Stator Overheat 5min	A	
874	TRIP(Major) : PBA over temp	A	

Category	Error Code	Error Name	Reset
Cycle	201	High Pressure (PD) protection - An error is triggered when Alarm 251 occurs four times cumulatively.	M
	202	Low pressure (PS) protection – An error is triggered when Alarm 252 occurs four times cumulatively.	M
	203	Compressor discharge temperature (TD) protection – An error is triggered when Alarm 253 occurs four times cumulatively.	M
	204	Compression ratio (CR) protection – An error is triggered when Alarm 254 occurs four times cumulatively.	M
	205	Overcurrent (CUR) protection – An error is triggered when Alarm 255 occurs four times cumulatively.	M
	206	HEATSINK protection – An error is triggered when Alarm 256 occurs four times cumulatively.	M
	207	Compressor temperature abnormality – An error is triggered when Alarm 257 occurs four times cumulatively.	M
	208	Compressor suction temperature (TS) protection – An error is triggered when Alarm 258 occurs three times cumulatively.	M
	209	Superheat protection – An error is triggered when Alarm 259 occurs three times cumulatively.	M
	210	High pressure switch (HPS) protection – An error is triggered when Alarm 260 occurs three times cumulatively.	M
Sensor	501	Temperature sensor (T_a, outdoor temperature) open/short	A
	505	Temperature sensor (TD, compressor discharge temperature) open/short	A
	506	Temperature sensor (TS, compressor suction temperature) open/short	A
	507	Temperature sensor (T_cond, condenser outlet temperature) open/short	A
	561	Pressure sensor (PD, compressor discharge pressure) open/short	A
	562	Pressure sensor (PS, compressor suction pressure) open/short	A
Communication	702	Outdoor unit ↔ Inverter driver communication failure	A
Inverter	801	TRIP(Major): Communication error – An error is triggered when Alarm 851 occurs four times cumulatively.	M
	802	TRIP(Major): Comp current sensor cumulative error – An error is triggered when Alarm 852 occurs four times cumulatively.	M
	803	TRIP(Major): DC Link sensor cumulative error – An error is triggered when Alarm 853 occurs four times cumulatively.	M
	804	TRIP(Major): PFCM current A cumulative error – An error is triggered when Alarm 854 occurs four times cumulatively.	M
	805	TRIP(Major): PFCM current B cumulative error – An error is triggered when Alarm 855 occurs four times cumulatively.	M
	806	TRIP(Major): Input voltage sensor cumulative error – An error is triggered when Alarm 856 occurs four times cumulatively.	M
	807	TRIP(Major): Software comp over current cumulative error – An error is triggered when Alarm 857 occurs four times cumulatively.	M
	808	TRIP(Major): Over current with comp current limit cumulative error – An error is triggered when Alarm 858 occurs four times cumulatively.	M

Category	Error Code	Error Name	Reset
Inverter	809	TRIP(Major): Over current with ID current limit cumulative error – An error is triggered when Alarm 859 occurs four times cumulatively.	M
	810	TRIP(Major): Hardware comp over current cumulative error – An error is triggered when Alarm 860 occurs four times cumulatively.	M
	811	TRIP(Major): PFC over current cumulative error – An error is triggered when Alarm 861 occurs four times cumulatively.	M
	812	TRIP(Major): Estimator fault cumulative error – An error is triggered when Alarm 862 occurs four times cumulatively.	M
	813	TRIP(Major): Comp starting error cumulative error – An error is triggered when Alarm 863 occurs four times cumulatively.	M
	814	TRIP(Major): Wire miss cumulative error – An error is triggered when Alarm 864 occurs four times cumulatively.	M
	815	TRIP(Major): Heatsink over temp cumulative error – An error is triggered when Alarm 865 occurs four times cumulatively.	M
	816	TRIP(Major): DC under voltage cumulative error – An error is triggered when Alarm 866 occurs four times cumulatively.	M
	817	TRIP(Major): DC over voltage cumulative error – An error is triggered when Alarm 867 occurs four times cumulatively.	M
	818	TRIP(Major): AC under voltage cumulative error – An error is triggered when Alarm 868 occurs four times cumulatively.	M
	819	TRIP(Major): AC over voltage cumulative error – An error is triggered when Alarm 869 occurs four times cumulatively.	M
	820	TRIP(Major): PFC unbalanced current cumulative error – An error is triggered when Alarm 870 occurs four times cumulatively.	M
	821	TRIP(Major): Fan motor error 5min cumulative error – An error is triggered when Alarm 871 occurs four times cumulatively.	M
	822	TRIP(Major): Discharge FET cumulative error – An error is triggered when Alarm 872 occurs four times cumulatively.	M
	823	TRIP(Major): Stator Overheat 5min cumulative error – An error is triggered when Alarm 873 occurs four times cumulatively.	M
824	TRIP(Major): PBA over temp cumulative error – An error is triggered when Alarm 874 occurs four times cumulatively.	M	
Unknown Cause	999	Error of unknown cause	M

*Cumulative count resets after one hour of continuous normal operation.

Note Manual(M) ,Auto(A)

6.2 Troubleshooting Error Codes

If you encounter an error code while using the product, refer to the diagnostic flowchart for step-by-step troubleshooting process.

6.2.1 Error 201 (PD protection operation cumulative error)

Error	Cause	Check Item
E201 A251	<ol style="list-style-type: none"> Occurs when the unit is charged with excessive refrigerant or the outdoor unit's heat exchange is not functioning properly May occur when the outdoor temperature is too high When service valves are closed There is excessive refrigerant 	<ol style="list-style-type: none"> Check the water injection Check the filter at the inlet of the outdoor heat exchanger Check the outdoor fan is operating normally Check for malfunction of the high pressure sensor Check the compressor

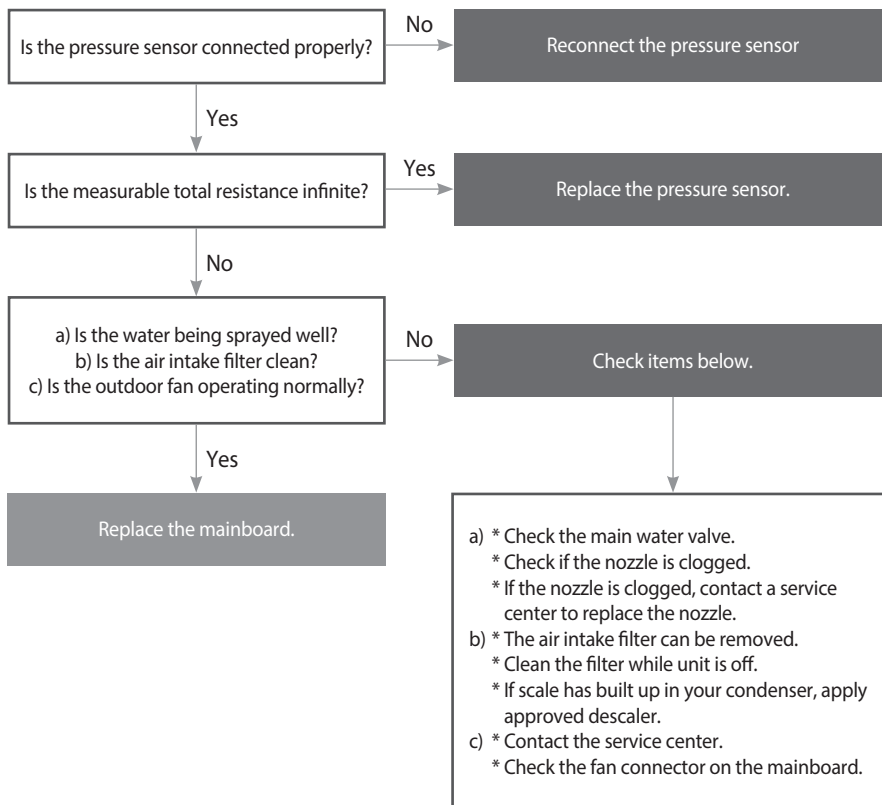

6.2.2 Error 202 (PS protection operation cumulative error)

Error	Cause	Check Item
E202 A252	<ol style="list-style-type: none"> 1. The refrigerant charge is insufficient or there is a leak 2. The refrigerant line is blocked 3. TXV malfunction 4. The outdoor temperature is too low 5. Airflow to the indoor unit is too low 	<ol style="list-style-type: none"> 1. Check the indoor unit airflow 2. Check the blockage of the indoor unit filter 3. Check the indoor fan is operating normally 4. Check the TXV 5. Check for refrigerant leaks 6. Check for malfunction of the low pressure sensor

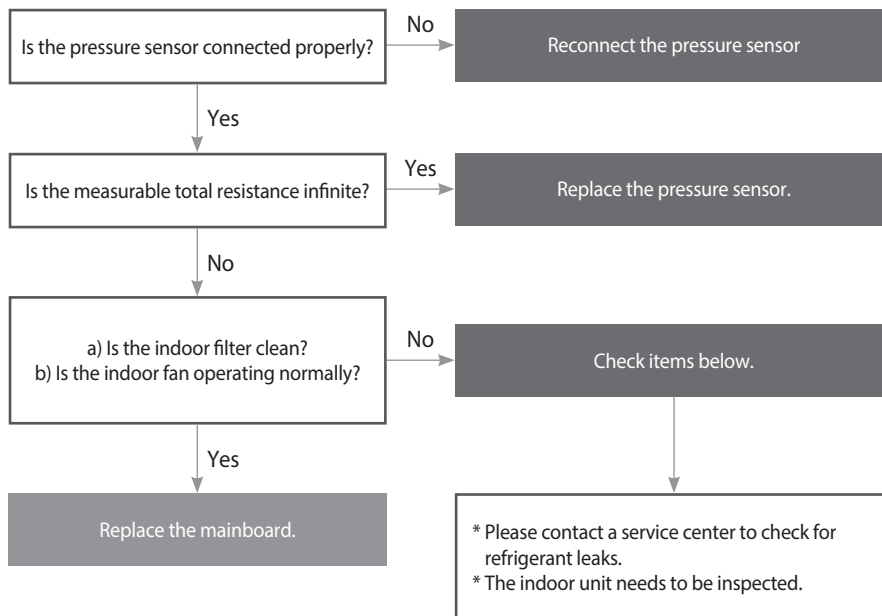

6.2.3 Error 203 (TD protection operation cumulative error)

Error	Cause	Check Item
E203 A253	<ol style="list-style-type: none"> 1. The refrigerant charge is insufficient 2. There is a leak 3. TXV malfunction 	<ol style="list-style-type: none"> 1. Check for refrigerant leaks 2. Check the TXV 3. Check the outdoor fan is operating normally 4. Check for malfunction of the TD sensor 5. Check the compressor

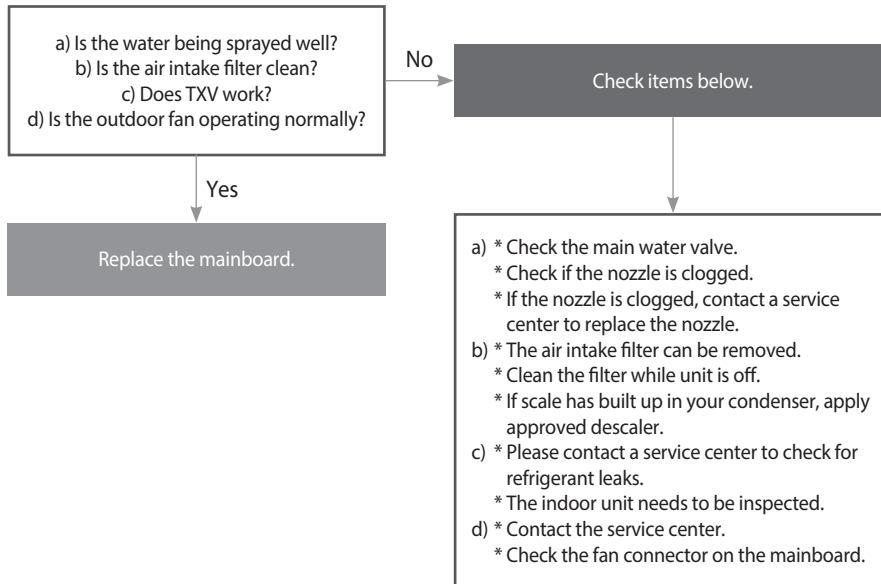

6.2.4 Error 204 (CR protection operation cumulative error)

Error	Cause	Check Item
E204 A254	<ol style="list-style-type: none"> 1. There is excessive refrigerant 2. When the outdoor heat exchange is not functioning 3. When the outdoor temperature is too high 	<ol style="list-style-type: none"> 1. Check the water injection 2. Check the filter at the inlet of the outdoor heat exchanger 3. Check the outdoor fan is operating normally 4. Check for malfunction of the high pressure sensor and low pressure sensor

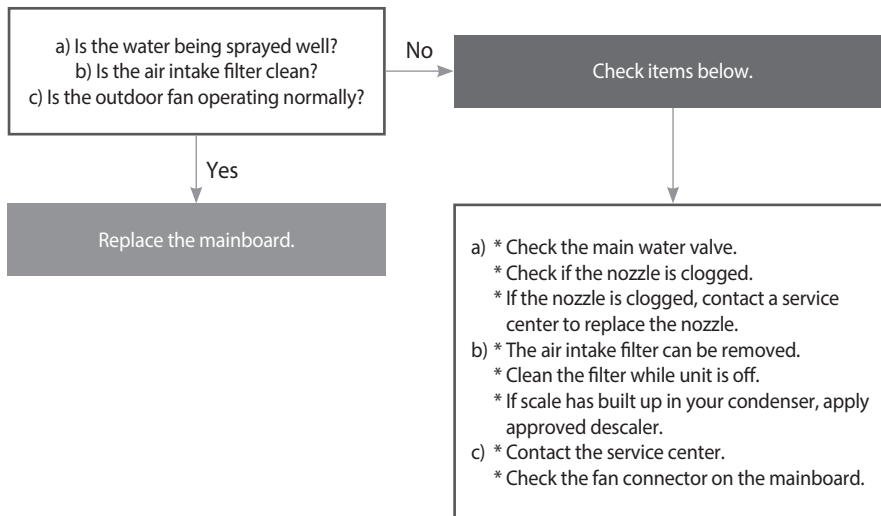

6.2.5 Error 205 (CUR protection operation cumulative error)

Error	Cause	Check Item
E205 A255	<ol style="list-style-type: none"> 1. When the compressor current is abnormally high 2. The refrigerant charge is excessive 3. When outdoor heat exchange is not functioning 4. TXV malfunction 	<ol style="list-style-type: none"> 1. Check the water injection 2. Check the filter at the inlet of the outdoor heat exchanger 3. Check the outdoor fan is operating normally 4. Check the compressor 5. Check the TXV

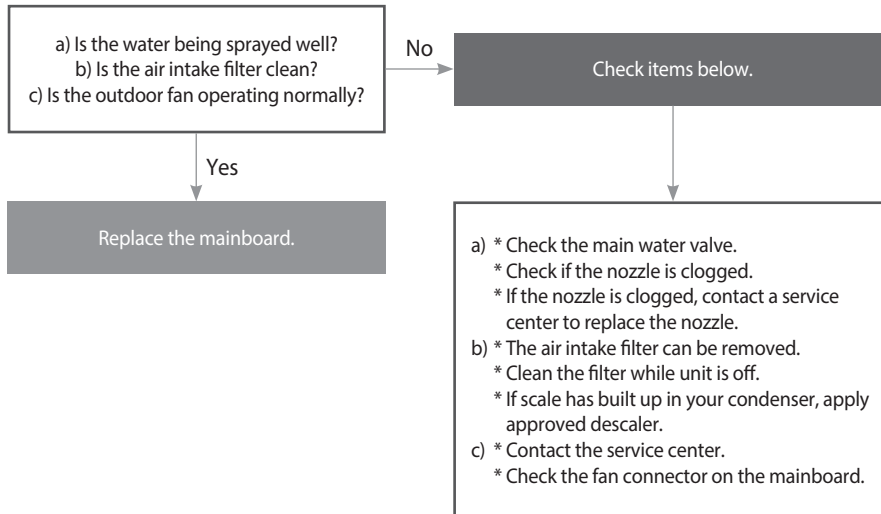

6.2.6 Error 206 (Heatsink protection operation cumulative error)

Error	Cause	Check Item
E206 A256	<ol style="list-style-type: none"> 1. Outdoor fan air flow is malfunctioning 2. Heat sink contamination 3. Inverter malfunction 	<ol style="list-style-type: none"> 1. Check the filter at the inlet of the outdoor heat exchanger 2. Check the outdoor fan is operating normally 3. Check the inverter heat sink conditions 4. Check for malfunction of the inverter

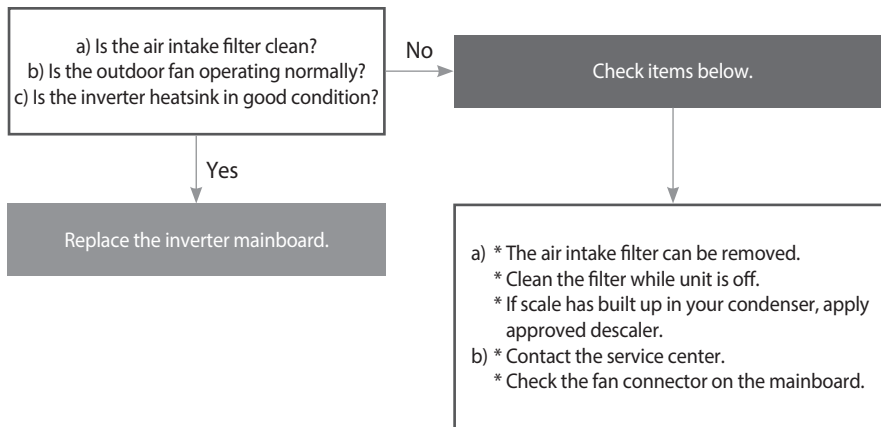

6.2.7 Error 207 (Compressor temperature abnormality cumulative error)

Error	Cause	Check Item
E207 A257	<ol style="list-style-type: none"> 1. Refrigerant leak 2. TXV malfunction 3. Compressor malfunction 	<ol style="list-style-type: none"> 1. Check for refrigerant leaks 2. TXV malfunction 3. Check for the malfunctioning of the compressor 4. Check for malfunction of the TD sensor and TS sensor 5. Check the inverter

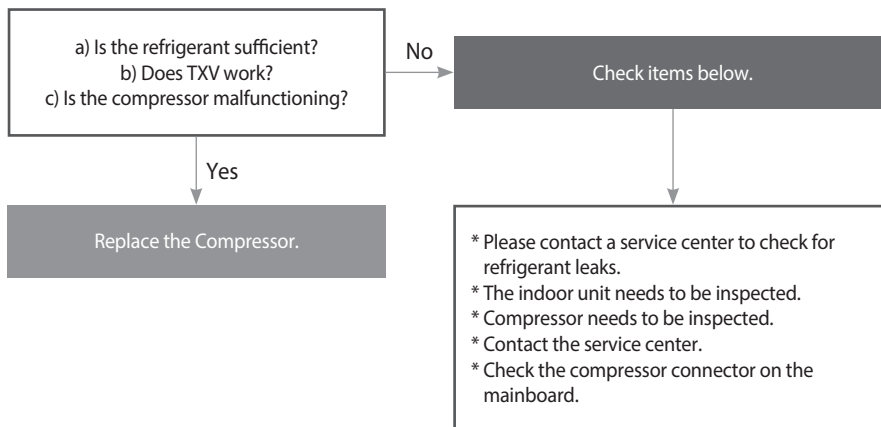

6.2.8 Error 208 (TS protection operation cumulative error)

Error	Cause	Check Item
E208 A258	1. The refrigerant charge is excessive 2. TXV malfunction	1. Check the TXV 2. Check the indoor fan is operating normally 3. Check for malfunction of the TS sensor

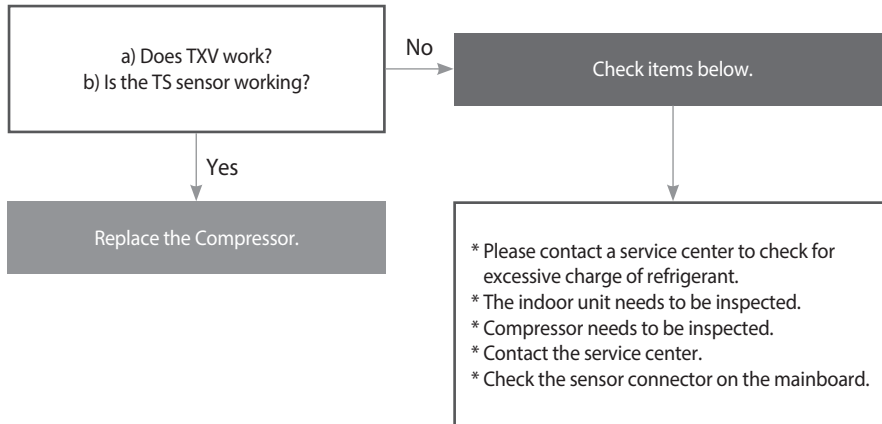

6.2.9 Error 209 (Superheat protection operation cumulative error)

Error	Cause	Check Item
E209 A259	<ol style="list-style-type: none"> 1. The refrigerant charge is excessive 2. Airflow to the indoor unit is too low or not functioning 3. TXV malfunction 	<ol style="list-style-type: none"> 1. Check the TXV 2. Check the filter at the inlet of the indoor heat exchanger 3. Check the indoor fan is operating normally 4. Check for malfunction of the low pressure sensor and TS sensor

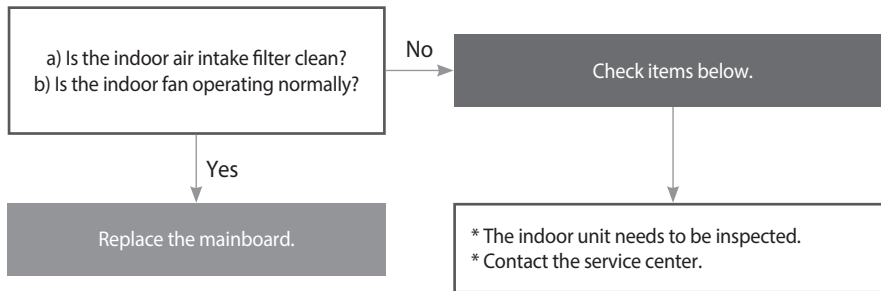

6.2.10 Error 210 (HPS protection operation cumulative error)

Error	Cause	Check Item
E210 A260	<ol style="list-style-type: none"> 1. Inverter malfunction 2. When outdoor heat exchange is not functioning 3. When the high pressure switch is malfunctioning 4. Overcharge of refrigerant 5. When the outside temperature is high 	<ol style="list-style-type: none"> 1. Check the filter at the inlet of the outdoor heat exchanger 2. Check the outdoor fan is operating normally 3. Check for malfunction of the inverter 4. Check for malfunction of the high pressure switch 5. Check the water injection

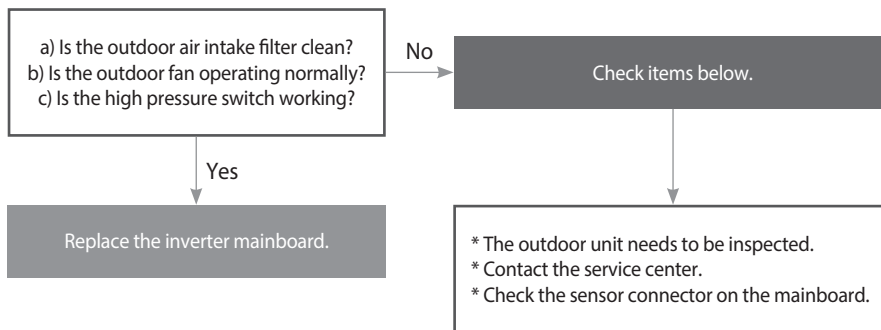

6.2.11 Error 501 (Outdoor Temp Sensor failure)

Error	Cause	Check Item
E501	1. Outdoor Temp sensor malfunction	1. Check and if found defective replace the outdoor sensor

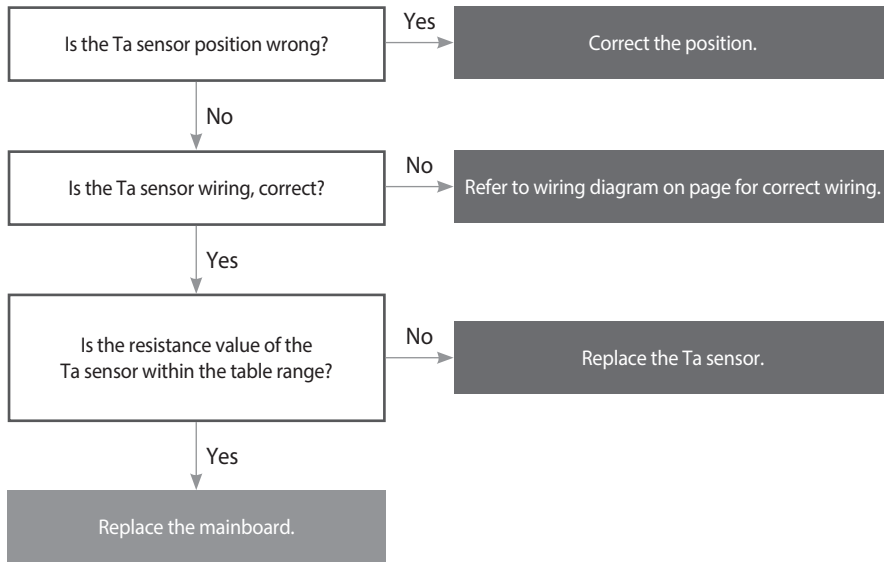

6.2.12 Error 505 (Compressor discharge Temp Sensor failure)

Error	Cause	Check Item
E505	1. Compressor discharge Temp sensor malfunction	1. Check and if found defective replace the compressor discharge temp sensor

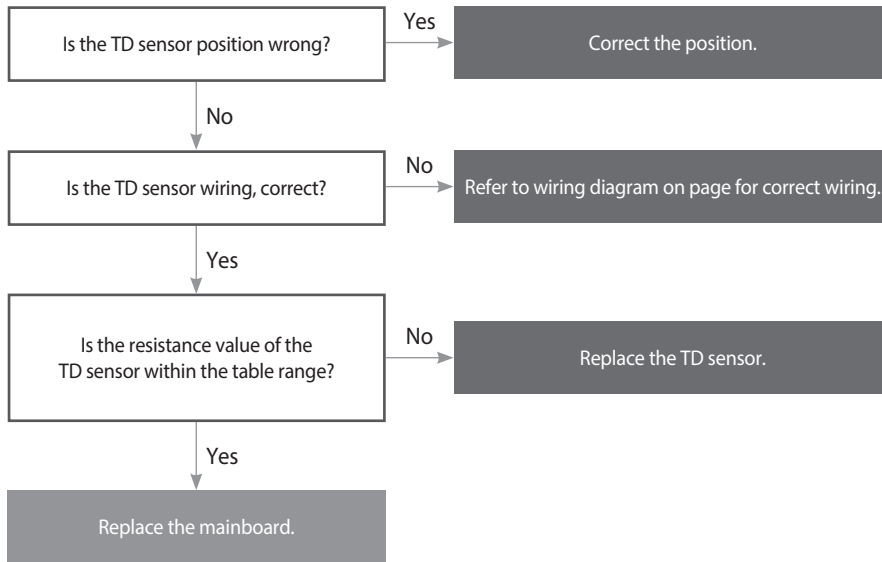

6.2.13 Error 506 (Compressor suction Temp Sensor failure)

Error	Cause	Check Item
E506	1. Compressor suction Temp sensor malfunction	1. Check and if found defective replace the compressor suction temp sensor

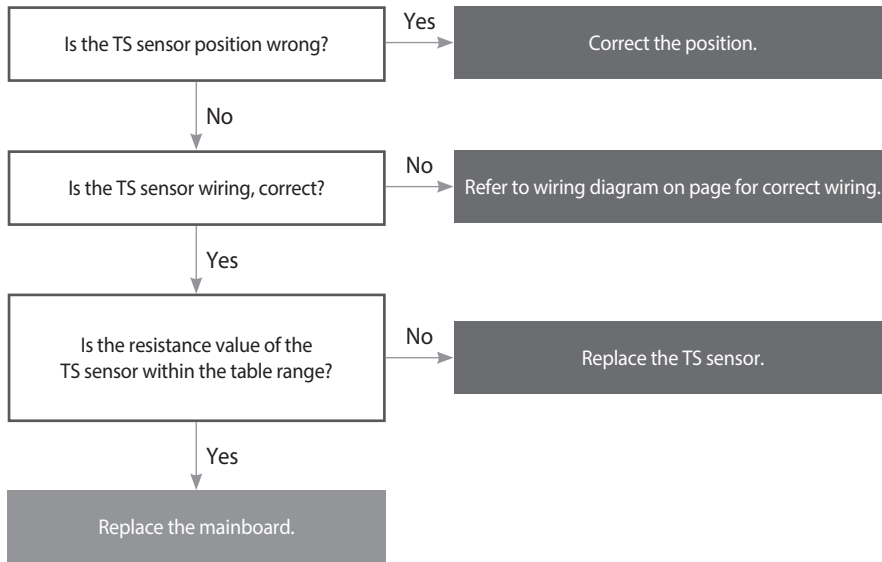

6.2.14 Error 507 (Condenser Temp Sensor failure)

Error	Cause	Check Item
E507	1. Condenser Temp sensor malfunction	1. Check and if found defective replace the condenser temp sensor

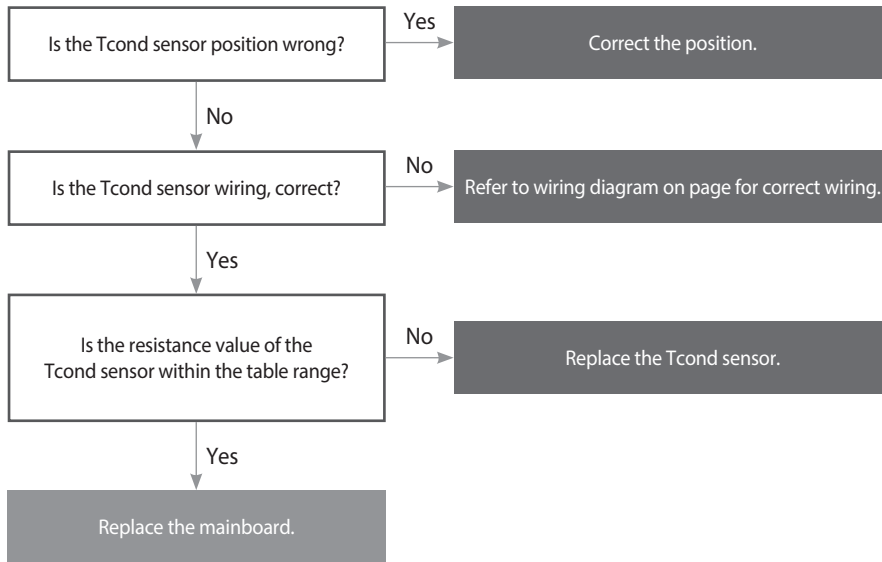

6.2.15 Error 561/562 (Compressor Pressure Sensor failure)

Error	Cause	Check Item
E561/562	1. Compressor high/low pressure sensor malfunction	1. Check and if found defective replace the compressor high/low pressure sensor

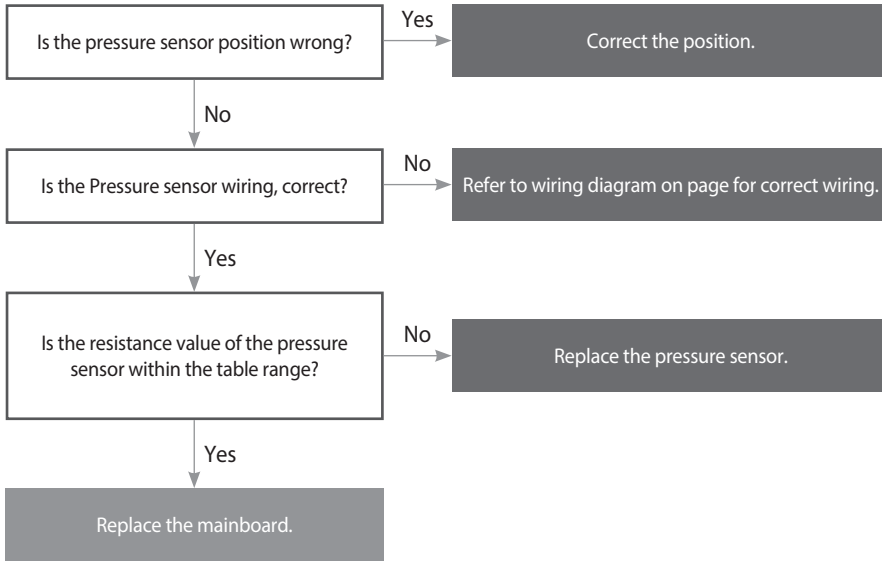

6.2.16 Error 702 (Outdoor unit ↔ Inverter driver communication failure)

Error	Cause	Check Item
E702	1. Inverter malfunction 2. Outdoor unit main controller malfunction 3. Communication connector malfunction	1. Check the inverter 2. Check the main controller 3. Replace the connector

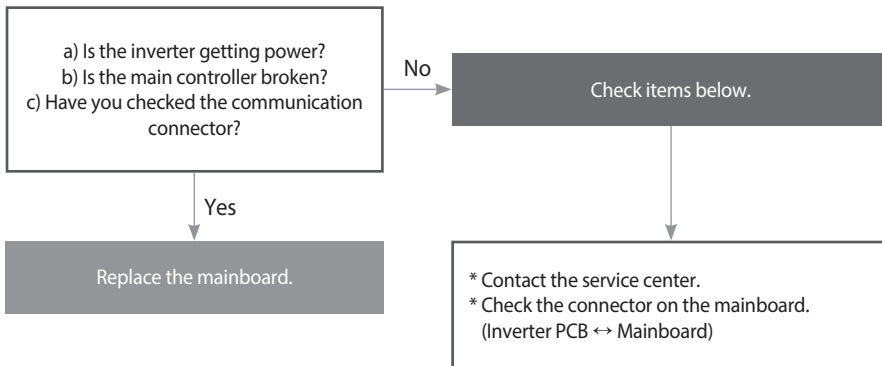

6.2.17 E801 TRIP: Communication error

Error	Cause	Check Item
E801	<ol style="list-style-type: none">1. Electrical noise2. Possible damage to inverter	<ol style="list-style-type: none">1. System will try to self-mitigate with repeated start attempts2. Replace inverter

6.2.18 E802 TRIP: Comp current sensor error

Error	Cause	Check Item
E802	Refer to Error code E205	Refer to Error code E205

6.2.19 E803 TRIP: DC Link sensor error

Error	Cause	Check Item
E803	<ol style="list-style-type: none">1. Sensor is broken or loose2. Input power is unstable, DC Link voltage is too high or too low3. Incorrect sensor value recognition due to firmware or board error	<ol style="list-style-type: none">1. Check sensor connector, replace if necessary2. Check input power3. Update firmware or replace inverter4. It may be a temporary problem, so reboot and check again

6.2.20 E804 TRIP: PFCM current A, B error

Error	Cause	Check Item
E804, E805	<ol style="list-style-type: none">1. Voltage imbalance or sudden voltage fluctuations2. PFCM internal or external current sensor failure, connector failure3. Inverter damage	<ol style="list-style-type: none">1. Check 3-phase power supply2. Check sensor connector, measure PFCM input and output current3. Check for overheating4. There may be temporary noise or sensor abnormality, so reboot and check again

6.2.21 E806 TRIP: Input voltage sensor error

Error	Cause	Check Item
E806	<ol style="list-style-type: none">1. Poor sensor or connector contact2. Unstable power supply, low/over voltage3. Momentary voltage increase or noise4. Inverter damage5. Leakage current due to poor grounding	<ol style="list-style-type: none">1. Check sensors and connectors2. Measure input voltage with a multimeter, check rated range3. Check EMI filter4. Replace inverter5. Measure ground resistance, re-ground6. Need to check if the error is due to temporary noise

6.2.22 E807 TRIP: Software comp over current error

Error	Cause	Check Item
E807	<ol style="list-style-type: none"> 1. Overcurrent 2. Current sensor error, damage, noise 3. Parameter setting error 4. Excessive load fluctuation 5. Inverter output instability 6. Early protection before hardware damage 	<ol style="list-style-type: none"> 1. Check compressor current (whether it exceeds the rating) 2. Check inverter and control board software 3. Check refrigerant light and blockage 4. Check power status 5. Replace inverter

6.2.23 E808 TRIP: Over current with comp, ID current limit error

Error	Cause	Check Item
E808, E809	<ol style="list-style-type: none"> 1. Outdoor Airflow too low or off 2. Incoming power supply voltage 3. Loose or incorrect wire connections 4. Phase imbalance 5. Refrigerant overcharge 6. Inverter damage 7. Compressor internal damage 	<ol style="list-style-type: none"> 1. Check ODU coil for clogging and clean if necessary; Troubleshoot ODU fan motor and make sure it is working 2. Check suction pressure transducer and suction temperature sensor 3. Inverter will reduce speed to a lower stage 4. Check voltage versus unit rating plate for allowable range 5. Check incoming power leads and leads to the compressor plug 6. Check compressor winding resistance or miswire of compressor leads at terminals U,V,W 7. Check refrigerant amount 8. Replace inverter 9. Replace compressor

6.2.24 E810 TRIP: Hardware comp over current error

Error	Cause	Check Item
E810	<ol style="list-style-type: none"> 1. Power instability, voltage drop 2. Inverter damage 3. Internal short circuit, sticking 4. Overload (refrigerant pressure abnormality, pipe blockage, oil shortage) 5. Refrigerant overfilling 6. Faulty connector 	<ol style="list-style-type: none"> 1. Check compressor current (whether it exceeds the rating) 2. Check compressor status (oil, status noise) 3. Check refrigerant amount and piping pressure 4. Check power and wiring status 5. Replace inverter 6. Replace compressor

6.2.25 E811 TRIP: PFC over current error

Error	Cause	Check Item
E811	<ol style="list-style-type: none"> 1. When the voltage is unstable or excessively high 2. Leakage current due to dust, moisture, etc. 3. Inverter damage 	<ol style="list-style-type: none"> 1. It may be a temporary error, so reboot and check 2. Check the input power 3. Replace inverter

6.2.26 E812 TRIP: Estimator fault error

Error	Cause	Check Item
E812	<ol style="list-style-type: none"> 1. Sensor failure (current sensor, voltage sensor failure) 2. Poor wire connection 3. Overload or compressor motor failure 4. Instability of input voltage 5. Noise and interference 	<ol style="list-style-type: none"> 1. Check the connection status of the motor and inverter and the sensor signal 2. Check if the voltage and current are stable 3. Apply the latest version of the inverter software 4. Initialize inverter 5. Replace inverter

6.2.27 E813 TRIP: Comp starting error

Error	Cause	Check Item
E813	<ol style="list-style-type: none"> 1. Poor power supply or voltage drop 2. Compressor internal abnormality 3. Overload protection device operation 4. Insufficient refrigerant or excessive load 5. Temperature sensor abnormality or inverter damage 6. Wiring fault and poor contact 	<ol style="list-style-type: none"> 1. Check the power voltage 2. Check the compressor parts 3. Check the wiring and connection status 4. Check the refrigerant status 5. Check the sensor 6. Replace the inverter

6.2.28 E814 TRIP: Wire miss error

Error	Cause	Check Item
E814	<ol style="list-style-type: none"> 1. Poor wiring connector contact 2. Missing wiring connection during installation 	<ol style="list-style-type: none"> 1. Check the wiring between the compressor, inverter, and control board 2. Check for damage to connectors 3. Check that all wires are properly connected

6.2.29 E815 TRIP: Heatsink over temp cumulative error

Error	Cause	Check Item
E815	Refer to Error code E210	Refer to Error code E210

6.2.30 E816 TRIP: DC under voltage error

Error	Cause	Check Item
E816	<ol style="list-style-type: none">1. Low supply line volt age(<197 VAC)2. Inverter internal damage	<ol style="list-style-type: none">1. Check supply voltage to ODU2. Replace inverter

6.2.31 E817 TRIP: DC over voltage error

Error	Cause	Check Item
E817	<ol style="list-style-type: none">1. High supply line volt age(<253 VAC)2. Inverter internal damage3. Compressor is suddenly unloaded	<ol style="list-style-type: none">1. Check supply voltage to ODU2. Replace inverter3. Check that the service valves are fully open

6.2.32 E818 TRIP: AC under voltage error

Error	Cause	Check Item
E818	<ol style="list-style-type: none">1. Low supply line volt age2. Inverter internal damage	<ol style="list-style-type: none">1. Check supply voltage to ODU2. Replace inverter

6.2.33 E819 TRIP: AC over voltage error

Error	Cause	Check Item
E819	<ol style="list-style-type: none">1. High supply line volt age2. Inverter internal damage3. Compressor is suddenly unloaded	<ol style="list-style-type: none">1. Check supply voltage to ODU2. Replace inverter3. Check that the service valves are fully open

6.2.34 E820 TRIP: PFC unbalanced current error

Error	Cause	Check Item
E820	<ol style="list-style-type: none">1. Power supply unstable or unbalanced2. Wire connection bad or open3. PFC circuit internal component defect4. Current imbalance5. Sensor abnormality	<ol style="list-style-type: none">1. Load status check2. PFC circuit component check3. Wiring connection status and contact failure check4. Power voltage and current status measurement

6.2.35 E821 TRIP: Fan motor error 5min cumulative error

Error	Cause	Check Item
E821	<ol style="list-style-type: none">1. Fan blade bent/out of balance2. Fan blade restricted3. Fan motor miswiring4. Inverter damage	<ol style="list-style-type: none">1. Check outdoor fan blade2. Check outdoor fan blade clearance3. Check outdoor fan motor connectors and harness4. Replace outdoor fan motor5. Replace inverter

6.2.36 E822 TRIP: Discharge FET error

Error	Cause	Check Item
E822	<ol style="list-style-type: none">1. FET self-damage (overheating, overcurrent, overvoltage, etc.)2. Poor connection3. Abnormal current flow4. Aging of components	<ol style="list-style-type: none">1. Check circuit and wiring (around FET)2. Check FET temperature and condition3. Recheck connections

6.2.37 E823 TRIP: Stator Overheat 5min error

Error	Cause	Check Item
E823	<ol style="list-style-type: none">1. There is a demand for stator heat but MOC doesn't detect it2. Damaged inverter	<ol style="list-style-type: none">1. Check Compressor winding resistance or miswire compressor leads at terminals U,V,W2. Replace Inverter

6.2.38 E824 TRIP: PBA over temp error

Error	Cause	Check Item
E822	Refer to Error code E210	Refer to Error code E210

6.3 Minor Code

Category	Minor Code	Minor Name	Reset
Heat Exchange	101	Condenser heat exchange abnormal alarm	A/M
Water Supply	301	Supply solenoid valve stuck alarm	A/M
	302	Drain solenoid valve stuck alarm	A/M
	303	Water supply abnormality alarm	A/M
Sensor	563	Water Pressure sensor open/short alarm	A
HW/SW	601	EEPROM	M
	602	Nor FLASH	M
Inverter	881	TRIP(Minor) : IPM temp sensor error	X
	882	TRIP(Minor) : PFCM temp sensor error	X
	883	TRIP(Minor) : ID current limit minor	X
	884	TRIP(Minor) : comp current limit minor	X
	885	TRIP(Minor) : AC over voltage	X
	886	TRIP(Minor) : PFC over current	X
	887	TRIP(Minor) : Input Current Limit	X

*Inverter minor codes refer to the error code contents

6.3.1 R101: Condenser heat exchange abnormal alarm

Alarm	Cause	Check Item
R101	<ol style="list-style-type: none"> 1. Condenser clogged with foreign matter, scale, etc 2. Fan motor failure 	<ol style="list-style-type: none"> 1. Check the heat exchanger surface 2. Check fan motor operation

6.3.2 R301 : Supply solenoid valve stuck alarm

Alarm	Cause	Check Item
R301	<ol style="list-style-type: none"> 1. Supply solenoid valve failure 	<ol style="list-style-type: none"> 1. Check the supply solenoid valve(On/Off) 2. Check the water pressure sensor

6.3.3 R302 : Drain solenoid valve stuck alarm

Alarm	Cause	Check Item
R302	<ol style="list-style-type: none"> 1. Drain solenoid valve failure 2. No power supply due to short circuit, missing, defective terminal block 	<ol style="list-style-type: none"> 1. Check the drain solenoid valve(On/Off)

6.3.4 R303 : Water supply abnormality alarm

Alarm	Cause	Check Item
R303	<ol style="list-style-type: none"> 1. Water is locked to prevent freezing and is not turned on when the season is ON 2. Consumer intentionally locks the water supply 3. Water cut-off 4. Sol Valve is stuck and remains in the OFF state 5. No power supply due to short circuit, missing, defective terminal block 6. Cannot be switched OFF due to sticking after drying operation 7. A small amount of foreign matter is stuck in the diaphragm, causing a small amount of water to leak from the drain valve 8. A large amount of foreign matter is stuck in the diaphragm, causing a large amount of water to leak from the drain valve 	<ol style="list-style-type: none"> 1. Check the supply solenoid valve (On/Off) 2. Check the drain solenoid valve (On/Off) 3. Check main water line

6.3.5 R563 : Water Pressure sensor open/short alarm

Alarm	Cause	Check Item
R563	<ol style="list-style-type: none"> 1. Water pressure sensor malfunction 	<ol style="list-style-type: none"> 1. Check and replace the water pressure sensor

6.3.6 R601 : EEPROM

Alarm	Cause	Check Item
R601	<ol style="list-style-type: none"> 1. Power instability or noise 2. Mainboard damage 	<ol style="list-style-type: none"> 1. It may be temporary, so reboot and check 2. Replce mainboard

6.3.7 R602 : NORFLASH

Alarm	Cause	Check Item
R602	<ol style="list-style-type: none"> 1. Power instability or noise 2. Mainboard damage 	<ol style="list-style-type: none"> 1. It may be temporary, so reboot and check 2. Replce mainboard

6.4 Care and Maintenance

For continued high performance and minimizing possibility of equipment failure, annual maintenance must be performed on this equipment. The frequency of maintenance may vary by region and water quality.

Precautions

WARNING

- Any maintenance and cleaning of outdoor units should only be carried out by qualified maintenance personnel.

WARNING

Electric Shock

- Disconnect the power before carrying out any repairs or maintenance.
- When servicing the unit control, label all wires before disconnecting them. Wiring errors can lead to improper and dangerous operation.

CAUTION

Contains high pressure refrigerant

The system contains high-pressure oil and refrigerant. Before opening the system, recover the refrigerant to release the pressure.

CAUTION

- Do not use chemicals or chemically treated cloth to clean the unit.
- Do not use benzene, paint thinner, polishing powder or other solvents to clean this unit.

Repairing Refrigerant Circuit

When opening the refrigerant circuit to make repairs, or for any other purpose, the following procedures must be used.

- Safely recover the refrigerant using a recovery pump certified for flammable refrigerants.
- Purge the refrigerant circuit with nitrogen gas.
- Evacuate the refrigerant circuit to 1500 microns.

NOTICE

Open the circuit by cutting or brazing.

Break the vacuum with a nitrogen purge of the refrigerant circuit ensuring that the outlet of the vacuum pump is not near a potential ignition source.

Replace the filter drier any time the refrigerant circuit is opened up.

Pre-Season Inspection and Maintenance

At the start of each cooling season, do the following:

- Turn off the unit and disconnect the power supply.
- Check for damaged wires and leaks.
- Clean indoor and outdoor coils as necessary.
- Clean the ODU and IDU drain pans.
- Clean the ODU pre-filter.
- Ensure proper refrigerant level.
- Check for leaks, proper airflows, and that condensate drains are clear.
- Check the air filters.
- Replace the water treatment filter to prevent scale build-up and cleaning of the nozzles.
- Annual service is strongly recommended. Product performance and lifespan may be reduced if not regularly maintained.

Notice at the beginning of the Cooling Season

- 1) Check to assure the air inlet/outlet of the units are not blocked.
- 2) Check that the ground connection is secure.
- 3) Check if the condenser air filter screen is clean and properly installed.
- 4) If starting up after a long-term shut down, turn the power switch to "ON" at least 8 hours before operation to preheat the crankcase of the compressor.
- 5) Make sure outdoor and indoor air filters are clean.

Maintenance at the End of the Using Season

- 1) Cut off the main power of air conditioner.
- 2) Clean the dust and sundries in outdoor unit.
- 3) Disassemble the strainer, drain the water inside, and reassemble.

Annual Coil Cleaning

User's should not power off the unit.

Step 1: Disconnect power to the unit. This should be done before any service work on any electrical equipment. In addition, appropriate personal protective equipment (safety glasses, gloves, etc.) should be worn.

Step 2: Remove surface debris — Remove surface dirt, leaves, fibers, etc. with a vacuum cleaner (preferably with a brush or other soft attachment rather than a metal tube). Blow compressed air from the inside out, and use a non-metallic soft-bristle brush to help with heavier particles, if necessary. Do not impact or scrape the coil with the vacuum tube or air nozzle.

Step 3: Rinse Do not use any chemicals (including those advertised as coil cleaners) to wash microchannel heat exchangers, as they can cause corrosion. Rinse only. Hose the microchannel heat exchanger off gently, preferably from the inside out and top to bottom, running the water through every fin passage until it comes out clean.

Microchannel fins are stronger than traditional tube-and-fin coil fins, but still need to be handled with care. Be careful not to damage the coil with **the metal end of the hose while cleaning the coil.**

7. Appendixes

7.1 Thermostat wiring

1Cool

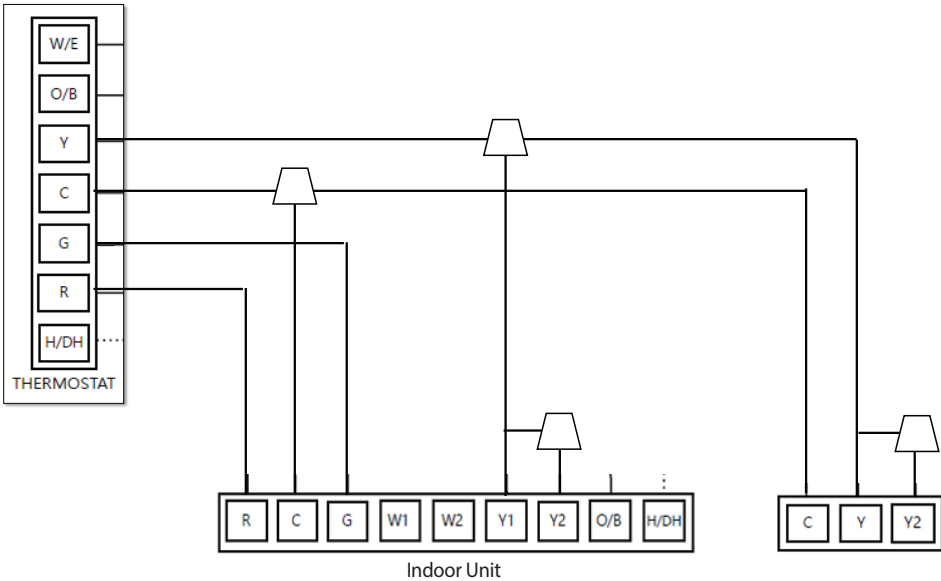

2Cool

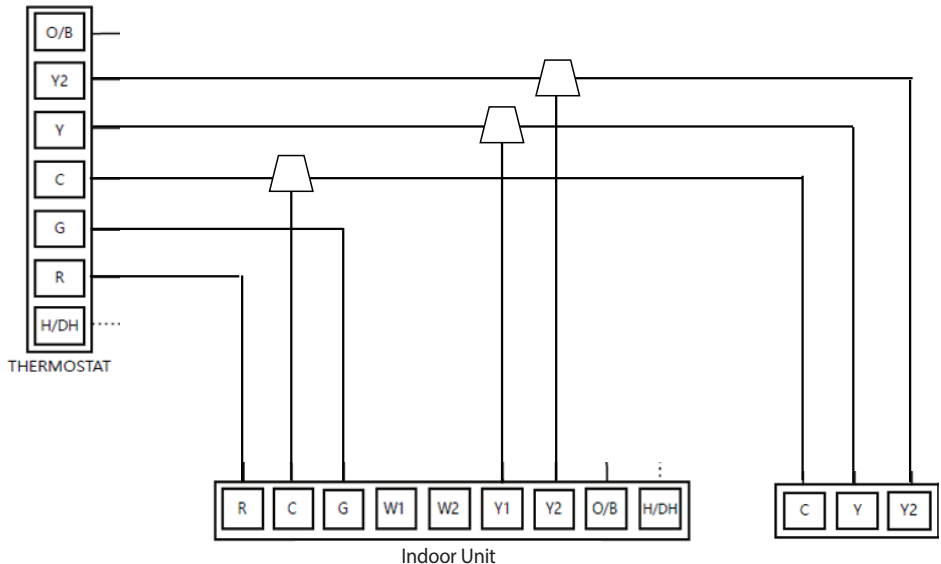

7.2 Wiring Diagram (NAE28V36)

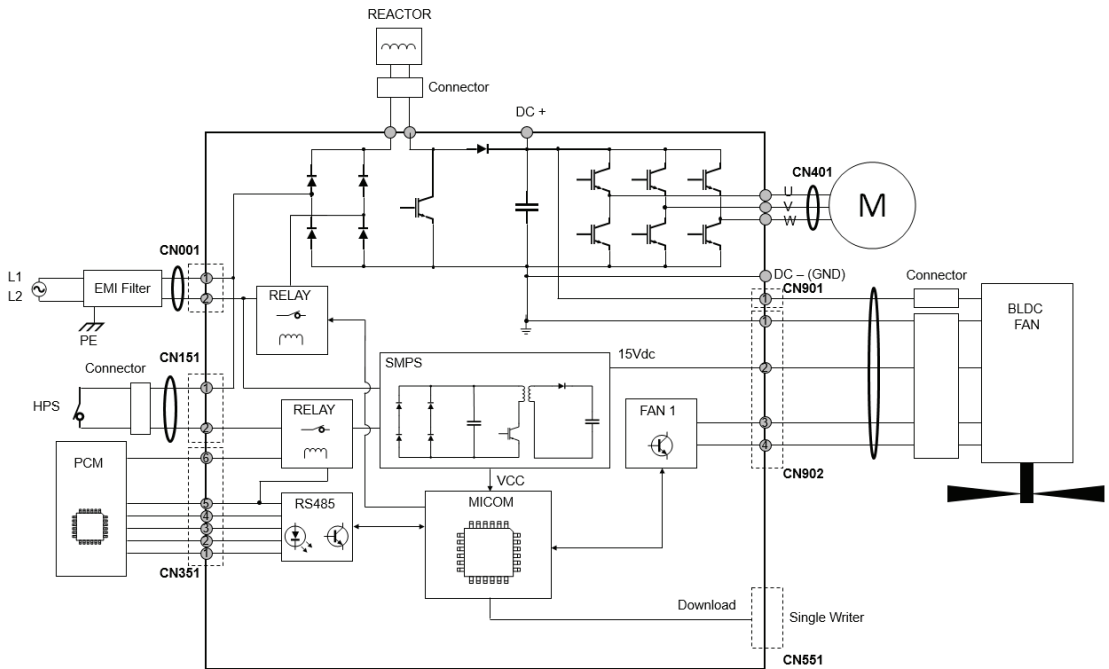
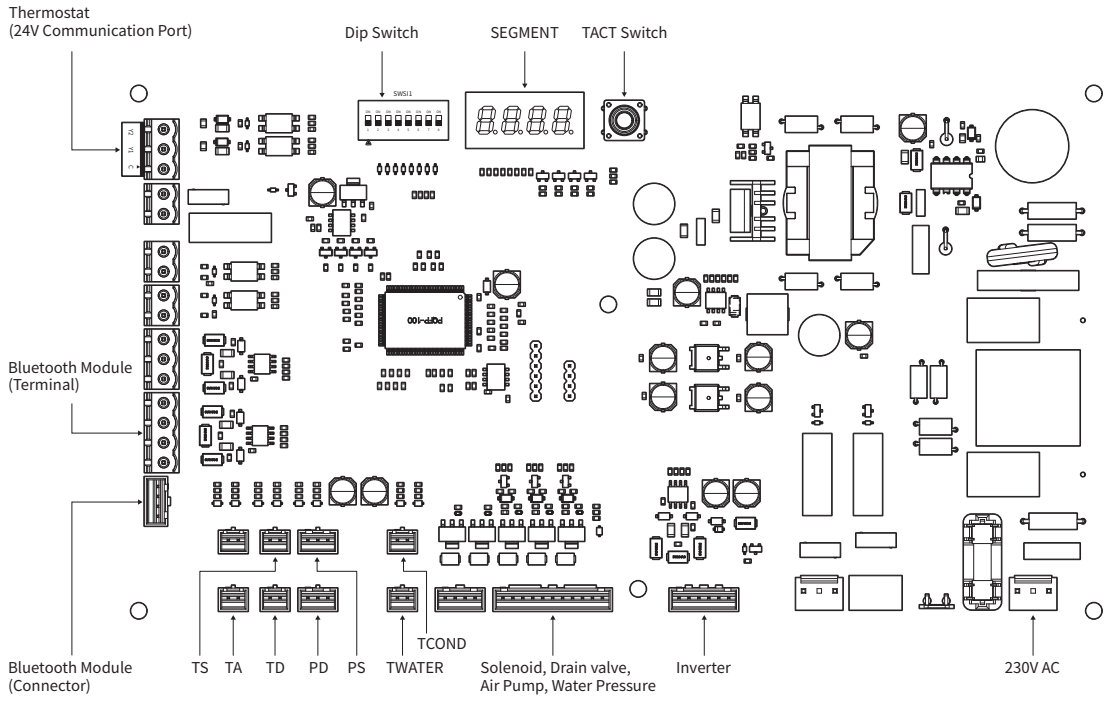

7.3 Wiring Diagram (NAE28V60)

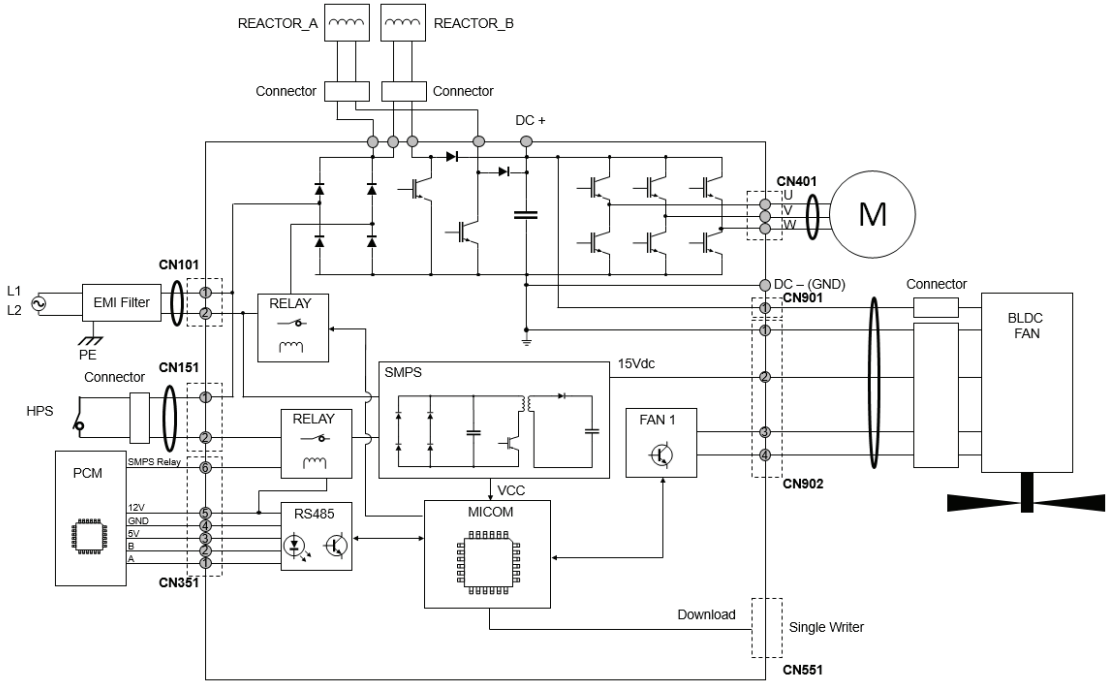
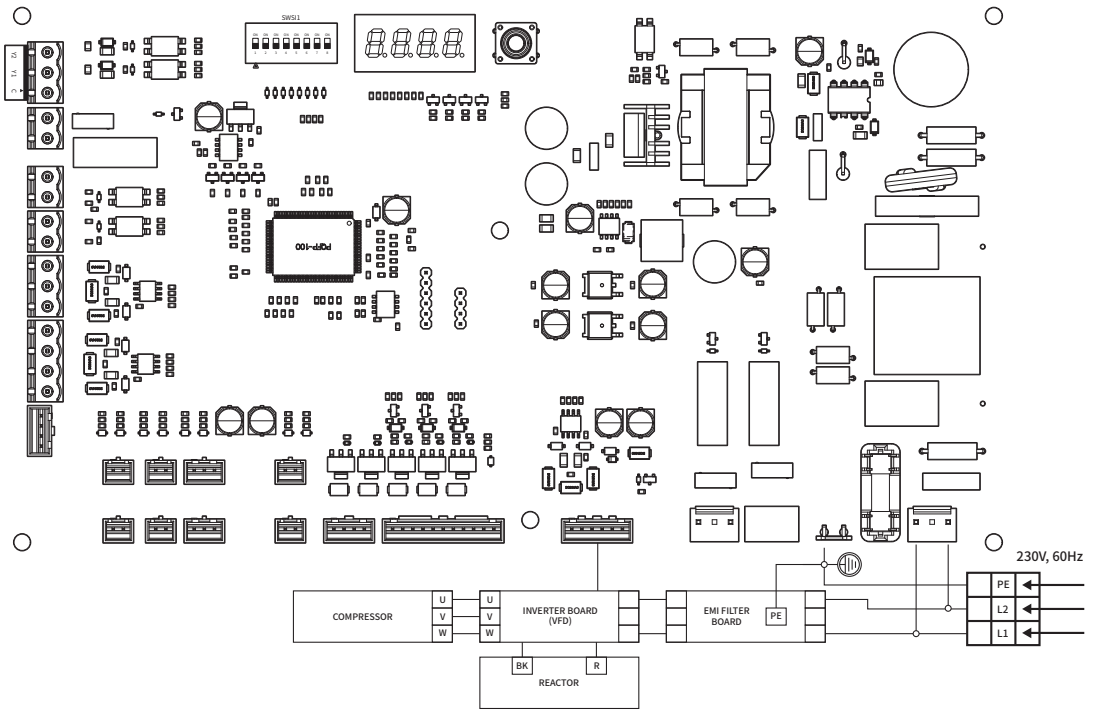

8. LIMITED WARRANTY NAVIEN, INC.

This Limited Warranty is provided by Navien, Inc. ("Navien") to cover only labor and parts for the Navien NAE Series Heat Pump ("Product") as originally installed in a Navien AHRI system.

How Long is the Coverage?

The warranty periods begin from the date of original installation ("Commencement Date"), and proof of such date must be provided to Navien. When the Product is installed in new construction, the Commencement Date shall be the date that the end-user takes title to the property. If proof of the installation date is unavailable, then the original installation date shall be deemed to be six months after the unit's manufacture date. If the Product is registered online within 60 days of the Commencement Date, the base limited warranty term shall be extended from "Non-Registered" to "Registered" as shown in the Coverage Table. Any Product not properly registered online within 60 days of the Commencement Date shall be subject to the "Non-Registered" base limited warranty. You may register the unit and receive an email confirmation for your records at <https://www.navieninc.com/register>.

What is Covered?

Subject to the terms and conditions set forth in this limited warranty, Navien will repair or furnish a replacement Part¹, at no charge, for installation by a qualified HVAC service provider, if the Part fails due to a manufacturing defect under normal use and maintenance. Purchaser must pay for any and all shipping and handling charges and other warranty service costs for the replacement Part. If a Part is not available, Navien will, at its option, a) provide a free suitable Part or b) provide a credit in the amount of the then factory selling price for a new suitable substitute Part that Purchaser may use towards the retail purchase price of a new Navien product. Any new Product purchase shall be at Purchaser's sole cost and expense including, but not limited to, all shipping, removal, and installation costs and expenses. Navien will pay reasonable labor charges for the repair subject to Navien's prior written approval and in accordance with Navien's schedule of approved labor allowances for a period of 90 days from the date of original installation. All repair Parts must be genuine Navien Parts unless otherwise authorized by Navien. All repairs and replacements must be performed by an individual or servicing company that is qualified to do the type of repair. During the applicable warranty period, replacement of the Product or Part requires Navien's direct prior written approval, and no third party is authorized to provide such approval on behalf of Navien. The replacement Part or Product will be warranted only for the unexpired portion of the applicable warranty period for the original Part or Product. Warranty rights will not be diminished or affected for residents of any jurisdiction, such as California and Quebec, that prohibit warranty benefits conditioned on registration.

Transfer of Warranty to Subsequent Owners

When ownership is transferred to a subsequent owner, while the Product remains at the site of original installation, warranties are reduced to the "Non-Registered"⁴ duration listed in the table below.

NAE-Coverage Table for Labor and Parts Only			
Residential ²			Commercial
Parts ¹	Registered ³	10years	1year
	Non-Registered ⁴	5years	
Labor	90days		

Definitions:

Parts¹ – Refers to all internal functional components of the unit.

Residential² – Refers to a Single-Family, residential application.

Registered³ – Refers to coverages for units registered within 60 days of the Commencement date.

Non-Registered⁴ – Refers to coverages for units registered 61 days or more after the Commencement Date.

Eligibility Requirements

To be covered under this limited warranty, the Product or Parts must meet the following requirements: (i) The Product must be in the same location where it was originally installed; (ii) The Product must be properly installed, operated, and maintained by a licensed HVAC service provider in accordance with the specifications or installation, operation, and maintenance instructions provided by Navien, and you must upon request, present written maintenance records, (iii) The Product or Parts replaced under this limited warranty must be given to the servicing provider for return to Navien; and (iv) All claims under this limited warranty must be filed within 30 days of the failure date.

How do I get service?

You must contact the original installer of your Product who must then contact Navien to report the issue. If you cannot find or do not wish to use the original installer, you may choose any service provider who is qualified to complete the necessary repair. Your service provider must contact and obtain approval from Navien's Technical Support team at 800-519-8794 or an authorized Navien distributor prior to commencing any warranty service. The installer and/or service provider must comply with Navien's warranty service and return procedures as available on Navien's website.

What is not covered?

Navien's Limited Warranty shall be void in the event of an occurrence of any of the following:

- Improper installation, including but not limited to, installation in violation of applicable rules, laws or building codes, incorrect refrigerant type, reinstallation at another location, etc.
- Failure to install the unit by a qualified HVAC installer.
- Accident, abuse or misuse including but not limited to installation for non-recommended uses, failure to follow or comply with the Manual, etc.
- Improper maintenance including but not limited to, operating in corrosive atmospheric elements, including but not limited to, chlorine, fluorine, salt, sulfur, recycled waste water, urine, fertilizers, rust, or other damaging substances or chemicals.
- Modification, alteration, addition of non-approved components, or misapplication of the Product in any manner.
- Damage or problems caused by electrical surges, flooding, fire, freezing, abnormal external temperature, force majeure, riot, act of war, or any acts of God.
- Performance problems caused by improper use of refrigerant lines, filter drier, electric service voltage, wiring, fusing or any other components, parts or specifications.
- Vibration and noise unless caused by a defect in materials or workmanship. Any other causes other than defects in materials or workmanship.
- Operating the Product at temperatures outside the factory calibrated temperature limits and/or exceeding the maximum setting of the high limit control.
- Installation at any location outside the United States or Canada.
- Conversion from R-454B refrigerant to other refrigerants or attempt to operate with a type of refrigerant not specified for the Air Conditioner.
- Accidental or intentional damage.
- Failure to perform normal maintenance as described in the manual, such as cleaning of the heat exchangers, unit cleaning and/or filter replacement.
- Parts or accessories not supplied or designated by the manufacturer.
- Any damage, or the need for any repairs, caused by frozen or broken heat exchanger, moisture intrusion, mold or other biological growth.
- Changes in the appearance of the unit that do not affect its performance.
- Replacement of fuses and replacement or resetting of circuit breakers.
- There is no warranty on any Product purchased through the internet or from any installer that obtained the Product from a supplier or distributor not authorized by Navien.
- Purchase of Product made on an uninstalled basis, whether direct, online or through a secondary or auction market.

Warranty Limitations

EXCEPT AS EXPRESSLY PROVIDED HEREIN, THERE ARE NO OTHER WARRANTIES, EXPRESSED OR IMPLIED, INCLUDING, BUT NOT LIMITED TO WARRANTIES OR MERCHANTABILITY OR FITNESS FOR A PARTICULAR PURPOSE, WHICH EXTEND BEYOND THE DESCRIPTION OF THE WARRANTY HEREIN AND FURTHER NAVIEN SHALL NOT BE LIABLE FOR INDIRECT, INCIDENTAL, SPECIAL, CONSEQUENTIAL, PUNITIVE OR OTHER SIMILAR DAMAGES THAT MAY ARISE, INCLUDING LOST PROFITS, DAMAGE TO A PERSON OR PROPERTY, LOSS OF USE, INCONVENIENCE, OR LIABILITY ARISING FROM IMPROPER INSTALLATION, SERVICE OR USE OF THE PRODUCT. ANY IMPLIED WARRANTIES OF MERCHANTABILITY AND FITNESS ARISING UNDER STATE LAW ARE LIMITED IN DURATION TO THE PERIOD OF COVERAGE PROVIDED BY THIS WARRANTY, UNLESS THE PERIOD PROVIDED BY STATE LAW IS LESS.

No one is authorized to make any other warranties on behalf of Navien. Some states do not allow the exclusion or limitation of incidental or consequential damages, or how long an implied warranty lasts, so the above limitation may not apply to you.

This Limited Warranty gives you specific legal rights and you may also have other rights which vary from state to state. If this Product is considered a consumer product, please be advised that some local laws do not allow exclusions or limitations on incidental or consequential damages, or limitations on how long a warranty lasts; or how long an implied warranty lasts, so that the above limitations may not apply to you. Refer to your local laws for your specific rights under this limited warranty. If you have any questions regarding this limited warranty, please contact your original installation dealer, or any participating dealer, should your original installation dealer no longer be available. No action arising out of any claimed breach of this limited warranty may be brought by the Purchaser (or any subsequent purchaser retaining the balance of a properly transferred limited warranty) more than one (1) year after the cause of action or claim has arisen.

Memo

Installation Instructions Manual

Getting Service

All repairs require pre-authorization by Technical Support.

- Request for your installer or any licensed professional to contact Technical Support at 1-800-519-8794 Option 2 once at the installation site.
- A short list of independent service providers in your area can be found on the website: www.navieninc.com/installers.

When seeking service, have the following information at hand:

- Model number
- Serial number
- Date purchased
- Installation location and type
- Error code, if any appears on the front control panel display.

Version: 1.0 (July, 2025)



Navien, Inc.
800.519.8794 www.navieninc.com
20 Goodyear, Irvine, CA 92618