

# Installation Manual

## NPE Condensing Water Heaters

### Model

NPE-180A2  
NPE-210A2  
NPE-240A2  
NPE-180S2  
NPE-210S2  
NPE-240S2  
  
NPE-150S2



ALWAYS read and follow this manual completely before using the water heater. Save for future reference.

Tested and Certified to NSF/ANSI 372 for lead free\* compliance.

\* The wetted surface of this product contacted by consumable water contains less than one quarter of one percent (0.25%) of lead by weight.

### **WARNING**

If the information in these instructions is not followed exactly, a fire or explosion may result, causing property damage, personal injury, or death.

**Do not store or use gasoline or other flammable vapors and liquids in the vicinity of this or any other appliance.**

#### **WHAT TO DO IF YOU SMELL GAS**

- Do not try to light any appliance.
- Do not touch any electrical switch; do not use any phone in your building.
- Immediately call your gas supplier from a neighbor's phone. Follow the gas supplier's instructions.
- If you cannot reach your gas supplier, call the fire department.

**Installation and service must be performed by a qualified installer, service agency or the gas supplier.**

**The installation must conform with local codes or, in the absence of local codes, the National Fuel Gas Code, ANSI Z223.1/NFPA 54 and/or CSA B149.1, Natural Gas and Propane Installation Code.**

**When applicable, the installation must conform with the Manufactured Home Construction and Safety Standard, Title 24 CFR, Part 3280 and/or CAN/CSA Z240 MH Series, Manufactured Home.**

**Do not install this water heater in a recreational vehicle, trailer, boat or other moving vehicles as it will result in a Carbon Monoxide Poisoning Hazard.**

# Contents

## 1. Important Safety Information 3

## 2. About the Water Heater 6

2.1	Included Items	6
2.2	Accessories	6
2.3	Specifications	7
2.4	The Front Panel	8
2.5	Components	9
2.6	Dimensions	12
2.7	Rating Plate	14

## 3. Installing the Water Heater 15

3.1	Choosing an Installation Location	15
3.2	Mounting the Water Heater to the Wall	18
3.3	Connecting the Gas Supply	19
3.4	Connecting the Water Supply	25
3.5	Connecting the Condensate Drain	38
3.6	Venting for Combustion Air	41
3.7	Connecting the Power Supply	59
3.8	Setting the DIP Switches	61

## 4. Configuring the Remote Controller System 63

4.1	Included Items	63
4.2	Accessories	63
4.3	Connecting the Extension Cable	63
4.4	Attaching the Wall Mounting Bracket	63
4.5	Remote Controller	64
4.6	Multi Remote Controller System	65
4.7	Entering Lock Mode	67
4.8	Setting the Clock	67
4.9	Setting the Recirculation Timer	68
4.10	Starting Recirculation	69
4.11	Canceling all Timer Settings	69

## 5. Installing a Cascade System 70

5.1	Connecting Water Supplies	70
5.2	Connecting the Communication Cables	72

## 6. Installing a Common Vent System 74

6.1	About the Common Vent System	74
-----	------------------------------	----

6.2	Navien Common Vent Collar Kit (Back-draft Damper)	80
6.3	Starting the Common Vent System	81
6.4	Connecting and Terminating the Vent Pipe	85
6.5	Installing a Condensate Drain	86
6.6	Setting up the Common Vent System	87
6.7	Common Vent Termination Clearances	87
6.8	Maintenance	88

## 7. Operating the Water Heater 90

7.1	Turning the Water Heater On or Off	90
7.2	Start-Up Wizard	90
7.3	Adjusting the Water Temperature	91
7.4	Accessing the Basic Menu Items	92
7.5	Accessing Advanced Menu Items	98

## 8. Appendixes 108

8.1	Gas & High Altitude Conversion	108
8.2	Flushing the Heat Exchanger	116
8.3	Technical Data	117
8.4	Wiring Diagram	120
8.5	Ladder Diagram	121
8.6	Component Assembly Diagrams and Parts Lists	122
8.7	Installation Checklist	135
8.8	Navien H2Air Add-on Controller Kit (Optional)	137
8.9	AHU Application with RS-485 Communication (optional)	139
8.10	Requirements for the State of Massachusetts	140

## 9. LIMITED WARRANTY NAVIEN, INC. 141

Product Installation Information	
Model	
Date Purchased	
Gas Type	
Serial Number	

# 1. Important Safety Information



The following Safety Alert Symbols are used in this manual. They are used to alert you to potential personal injury hazards. Obey all safety messages that follow this symbol to avoid possible serious injury or death. This Safety Alert Symbol precedes any safety message about risk of personal injury. It may also be accompanied by one of the following signal words.

If the information in these instructions is not followed exactly, a fire or explosion may result, causing property damage, personal injury or death.

## DANGER

Indicates a hazardous situation that if not avoided will result in death or serious injury.

## WARNING

Indicates a hazardous situation that if not avoided could result in death or serious injury.

## CAUTION

Indicates a potentially hazardous situation that if not avoided could result in minor or moderate injury.

## **NOTICE**

Indicates information considered important but not hazard-related (such as property damage).

## WARNING

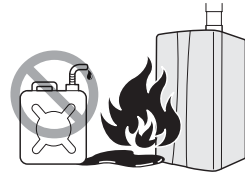

### **If you smell gas:**

- Do not try to light any appliance.
- Do not touch any electrical switches or use landline phones.
- From a neighbor's phone, call your gas provider and follow their instructions.
- If you cannot reach your gas provider, call the fire department.

### **Do not use or store flammable products, such as gasoline, solvents, or adhesives in the same room or area as the water heater.**

- The water heater has a main burner flame that can turn on at any time and can ignite flammable vapors. Vapors from flammable liquids can explode and catch fire, causing death or severe burns.
- Vapors cannot be seen and are heavier than air. They can travel long distances along the ground and can be carried from other rooms to the water heater's main burner flame by air current.
- Keep all flammable products far away from the water heater and store them in approved containers. Keep the containers closed tightly and out of the reach of children and pets.

## **⚠ WARNING**

To prevent death, serious injury, or property damage:

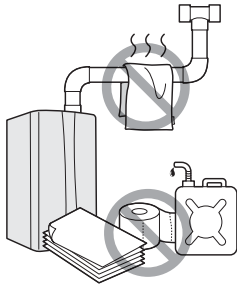

- **Do not store or use gasoline or other flammable liquids near this water heater.**  
Doing so may result in fire or explosion.
- **Do not place combustibles, such as newspapers or laundry, near the water heater or venting system.**  
Doing so may result in a fire.
- **Do not place or use hair sprays, spray paints, or any other compressed gases near the water heater or venting system, including the vent termination.**  
Doing so may result in fire or explosion.
- **Do not remove the front cover unless the power to the water heater is turned off or disconnected.**  
Failure to do so may result in electric shock.
- **Do not operate the water heater with the front cover opened.**  
Doing so may result in fire or carbon monoxide (CO) poisoning, which may result in property damage, personal injury, or death.
- **Do not operate this water heater without proper venting.**  
Doing so may result in fire or carbon monoxide (CO) poisoning, which may result in property damage, personal injury, or death.
- **Do not touch the power cord or internal components of the water heater with wet hands.**  
Doing so may result in electric shock.

California law requires the following Prop 65 warning to be provided:

## **⚠ WARNING**

Cancer and Reproductive Harm -  
[www.P65Warnings.ca.gov](http://www.P65Warnings.ca.gov)

## **⚠ WARNING**

To prevent death, serious injury, or property damage:

- **Do not turn on the water heater unless the water and gas supplies are fully opened.**  
Doing so may damage the water heater.
- **Do not turn on the water if the cold water supply shut-off valve is closed.**  
Doing so may damage the water heater.
- **Do not use this water heater for anything other than its intended purpose, as described in this manual.**
- **When servicing the controls, label all wires prior to disconnecting them.**  
Failure to do so may result in wiring errors, which can lead to improper or dangerous operation. Verify proper operation after servicing.
- **Do not use unapproved replacement or accessory parts.**  
Doing so may result in improper or dangerous operation and will void the manufacturer's warranty.
- **Do not place anything in or around the vent terminals, such as a clothes line, that could obstruct the air flow in or out of the water heater.**
- **This water heater has been approved for use in the USA and Canada only.**  
Using the water heater in any other country will void the manufacturer's warranty.

## **⚠ DANGER**

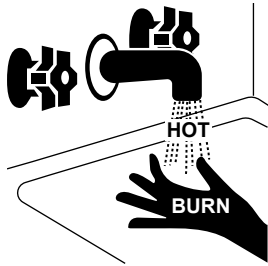

Water temperatures over 125°F (52°C) can cause severe burns instantly or death from scalds. Children, disabled and elderly are at highest risk of being scalded. Feel water with your elbow before bathing or showering. Temperature limiting valves are available, contact a licensed plumber for more information.

### **To prevent burns:**

- Use the lowest operating temperature setting necessary to provide comfortably-hot water.
- If your household has children or elderly or disabled residents, consider using a lower temperature setting.
- Check local codes for maximum water temperature setting allowed when used in nursing homes, schools, day care centers and other public applications.
- Do not leave children, the elderly, or disabled persons unsupervised.
- Do not allow small children to play unsupervised in the bathroom.
- Do not allow anyone to change the water temperature while hot water is running.
- Read all the instructions in this manual carefully before changing the temperature setting.
- Feel the water before using it on children, the elderly, or the disabled.
- If it is necessary to set the water temperature above 125°F (52°C), consider installing a thermostatically-controlled mixing valve or temperature-limiting valve. Contact a licensed plumber or your local plumbing authority for more information.

## **⚠ DANGER**

This water heater's water temperature is set to 120°F (49°C) at the factory for your safety and comfort. Increasing the temperature increases the risk of accidental scalding. Water temperatures at or above 125°F (52°C) can cause instant scalding, severe burns, or death. Before you decide to change the temperature setting, read the following table carefully.

Water Temperature	Time in which a young child can suffer a full thickness (3rd degree) burn
160°F (70°C)	Less than 1 second
140°F (60°C)	1 second
130°F (55°C)	10 seconds
120°F (49°C)	10 minutes
100°F (37°C)	very low scald risk

## **SAVE THESE INSTRUCTIONS**

### **⚠ DANGER**

Indicates a hazardous situation that if not avoided will result in severe injury or death.

### **⚠ WARNING**

Indicates a hazardous situation that if not avoided could result in death or serious injury.

### **⚠ CAUTION**

Indicates a potentially hazardous situation that if not avoided could result in minor or moderate injury.









### **NOTICE**

Indicates information considered important but not hazard-related (such as property damage).

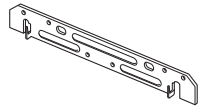
## 2. About the Water Heater

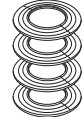
### 2.1 Included Items

When you open the box, you will find the following items with the water heater. Check the box for each of the following items before installing the water heater.





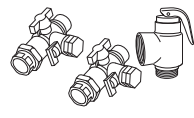

	
Installation Manual	Quick Installation Guide
	
Wall Mounting Bracket	Tapping Screws & Anchors
	
2 in. Vent Termination Caps	2 in. Wall Flanges
	
High Altitude Conversion Kit (Natural Gas Only)*	Propane Gas & High Altitude Conversion Kit*
	
HotButton Controller	

\* High Altitude Conversion kit and Propane Gas & High Altitude Conversion Kit are attached to the inside of the product case after the front cover has been removed.

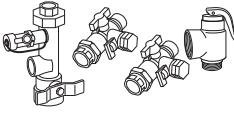
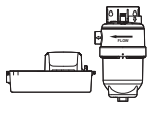
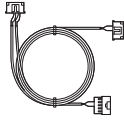
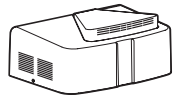
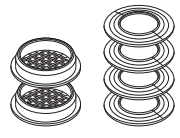
### 2.2 Accessories

The following optional accessories are available for the water heater:

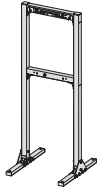
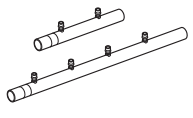
	
Remote Controller	Plumb Easy Valve Set with PRV

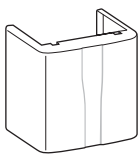
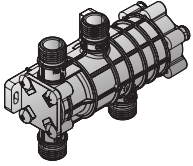
	
NPE-A2 Plumb Easy 3 Valve Set (for recirculation)	Condensate Neutralizer
	
Ready-Link Communication Cable	Outdoor Vent Kit
	
3 in. Wall Flanges & Vent termination Caps	External Pump Connector (<150 W, 1.5 A)
	
H2Air Add-on Controller Kit	Navi-Link (Wi-Fi Control System)
	
Ready-Link Rack	Ready-Link Manifold
	
HotButton Push Button	HotButton Wall Plate
	
Pipe Cover	NaviCirc

## 2.3 Specifications

The following table lists the specifications for the water heater. Additional specifications about water, gas, electric, and air supplies (venting) appear in the Installation section.





Item		NPE-150S2	NPE-180A2	NPE-180S2	NPE-210A2	NPE-210S2	NPE-240A2	NPE-240S2
Heat Capacity (Input)	Natural Gas, Propane Gas	18,000-120,000 BTU/H	10,000-150,000 BTU/H		12,000-180,000 BTU/H		13,300-199,900 BTU/H	
Uniform Energy Factor	UEF (for NG & LP)	0.93	0.95	0.96	0.95	0.96	0.95	0.96
EnergyStar Approved Models		No	Yes					
Flow Rate (DHW)	35 °F (19 °C) Temp Rise	6.8 GPM (25.8 L/m)	8.4 GPM (32 L/m)		10.1 GPM (38 L/m)		11.2 GPM (42 L/m)	
	45 °F (25 °C) Temp Rise	5.3 GPM (20 L/m)	6.5 GPM (25 L/m)		7.8 GPM (30 L/m)		8.7 GPM (33 L/m)	
	67 °F (36 °C) Temp Rise	3.4 GPM (13 L/m)	4.3 GPM (16 L/m)	4.4 GPM (17 L/m)	5.0 GPM (19 L/m)	5.3 GPM (20 L/m)	5.6 GPM (21 L/m)	5.8 GPM (22 L/m)
Dimensions		17.3 in. (W) x 27.4 in. (H) x 13.2 in. (D)						
Weight		62 lbs (28 kg)	73 lbs (33 kg)	68 lbs (31 kg)	77 lbs (35 kg)	73 lbs (33 kg)	77 lbs (35 kg)	73 lbs (33 kg)
Installation Type		Indoor or Outdoor Wall-Hung						
Venting Type		Forced Draft Direct Vent						
Ignition		Electronic Ignition						
Water Pressure		15-150 PSI						
Natural Gas Supply Pressure (from source)		3.5 in. WC-10.5 in. WC						
Propane Gas Supply Pressure (from source)		8 in. WC-13in. WC						
Natural Gas Manifold Pressure (min/max)		-0.04 in. WC/-0.40 in. WC	-0.03 in. WC/-0.55 in. WC		-0.03 in. WC/-0.76 in. WC		-0.03 in. WC/-0.96 in. WC	
Propane Gas Manifold Pressure (min/max)		-0.03 in. WC/-0.40 in. WC	-0.02 in. WC/-0.55 in. WC		-0.02 in. WC/-0.76 in. WC		-0.02 in. WC/-0.96 in. WC	
Minimum Flow Rate		0.5 GPM (1.9 L/m), < 0.01 GPM (0.04 L/m) option for "A2" models*						
Connection Sizes	Cold Water Inlet	¾ in. NPT						
	Hot Water Outlet	¾ in. NPT						
	Gas Inlet	¾ in. NPT						
Power Supply	Main Supply	120 V AC, 60 Hz						
	Maximum Power Consumption	200 W (max 2 A), 350 W (max 4 A) with external pump connected						
Materials	Casing	Cold Rolled Carbon Steel						
	Heat Exchangers	Primary Heat Exchanger: Stainless Steel Secondary Heat Exchanger: Stainless Steel						
Venting	Exhaust	2 in. or 3 in. PVC, CPVC, Approved Polypropylene, Stainless Steel 2 in. or 3 in. Special Gas Vent Type BH (Class II, A/B/C)						
	Intake	2 in. or 3 in. PVC, CPVC, Approved Polypropylene, Stainless Steel 2 in. or 3 in. Special Gas Vent Type BH (Class II, A/B/C)						
	Vent Clearances	0 in. to combustibles						
Safety Devices	Flame Rod, APS, Ignition Operation Detector, Water Temperature High Limit Switch, Exhaust Temperature High Limit Sensor, Power Surge Fuse, Burner High Limit Fuse, Vent Installation Detector (VID)							

\* Available for "A2" models when the optional ComfortFlow recirculation is active. Energy consumption will increase when the system is configured for circulation.

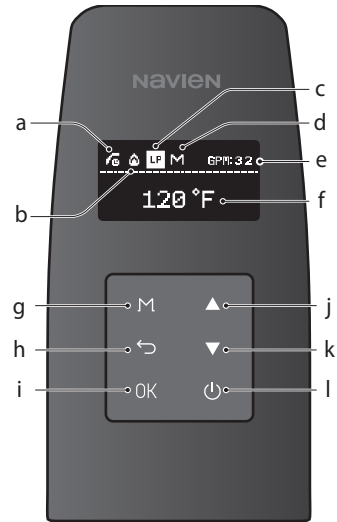
## 2.4 The Front Panel

The front panel allows you to adjust the water temperature and view the operating status or error codes. Remove the protective sheet from the front panel before using it.



a	   SH	<b>Recirculation/Space Heating</b> Displays recirculation (Always On/Intelligent/Weekly/HotButton) and space heating (with optional H2Air kit) status.	b	 	<b>Combustion/Error</b> Displays combustion/error status.
c	LP	<b>Gas</b> Displays when the unit is configured for propane gas.	d	MS	<b>Main/Sub</b> Displays whether the water heater is a main or a sub unit of the cascade system.
e	GPM: 3.2	<b>Status/Flow</b> Displays the operation status (including Stand-by) and current flow rate.	f	120 °F	<b>Hot Water Temperature Setting</b> Displays the hot water temperature setting.
g	M	<b>Menu button</b> Access to the Main menu screen.	h		<b>Back button</b> Access to the previous screen.
i	OK	<b>OK button</b> Access to the selected item.	j		<b>Up button</b> Increases the temperature setting, parameter or moves up.
k		<b>Down button</b> Decreases the temperature setting, parameter or moves down.	l		<b>Power button</b> Turns the water heater on or off.

## 2.5 Components

The following diagram shows the key components of the water heater. Component assembly diagrams and particular parts lists are included in the Appendixes.

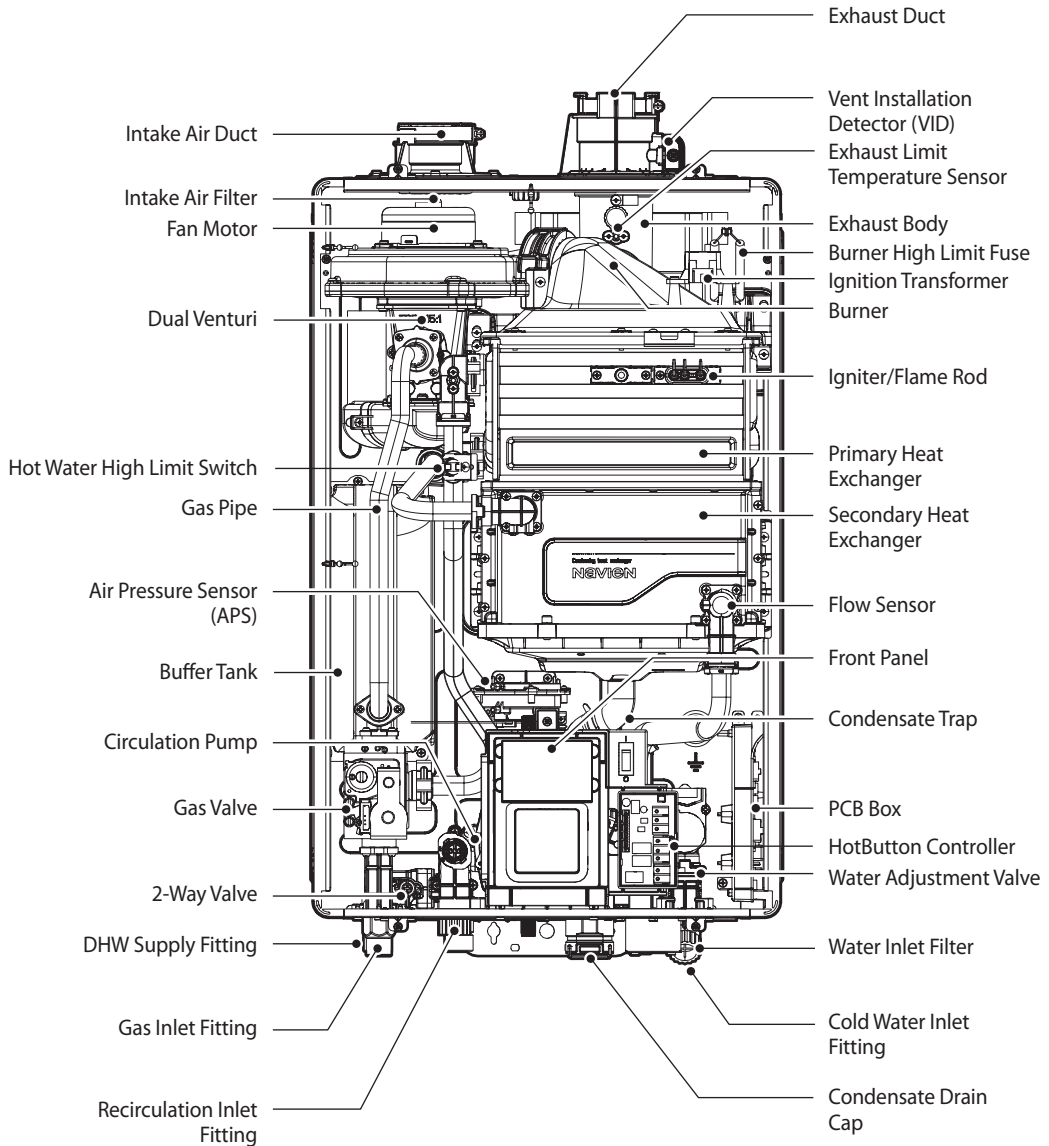

**[NPE-180A2/ 210A2/ 240A2]**

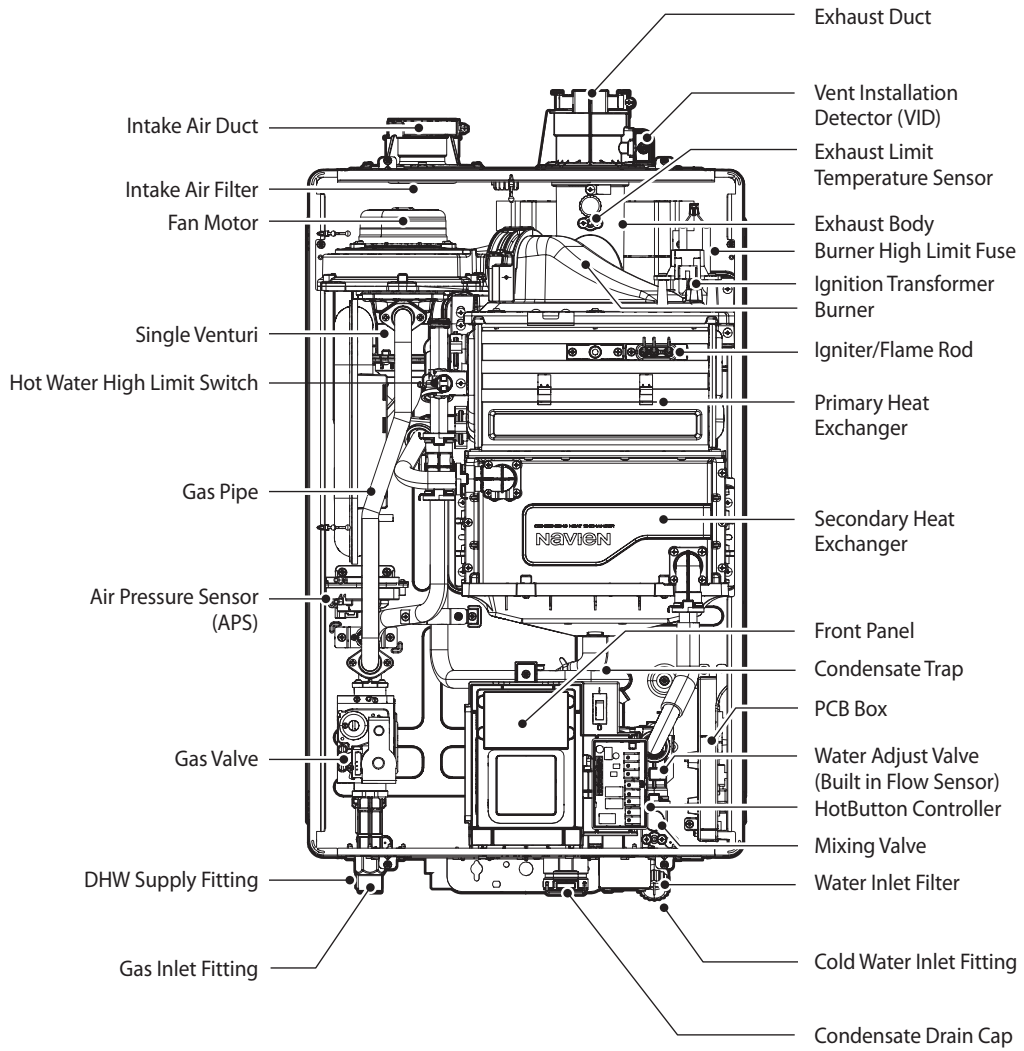

**[NPE-150S2]**

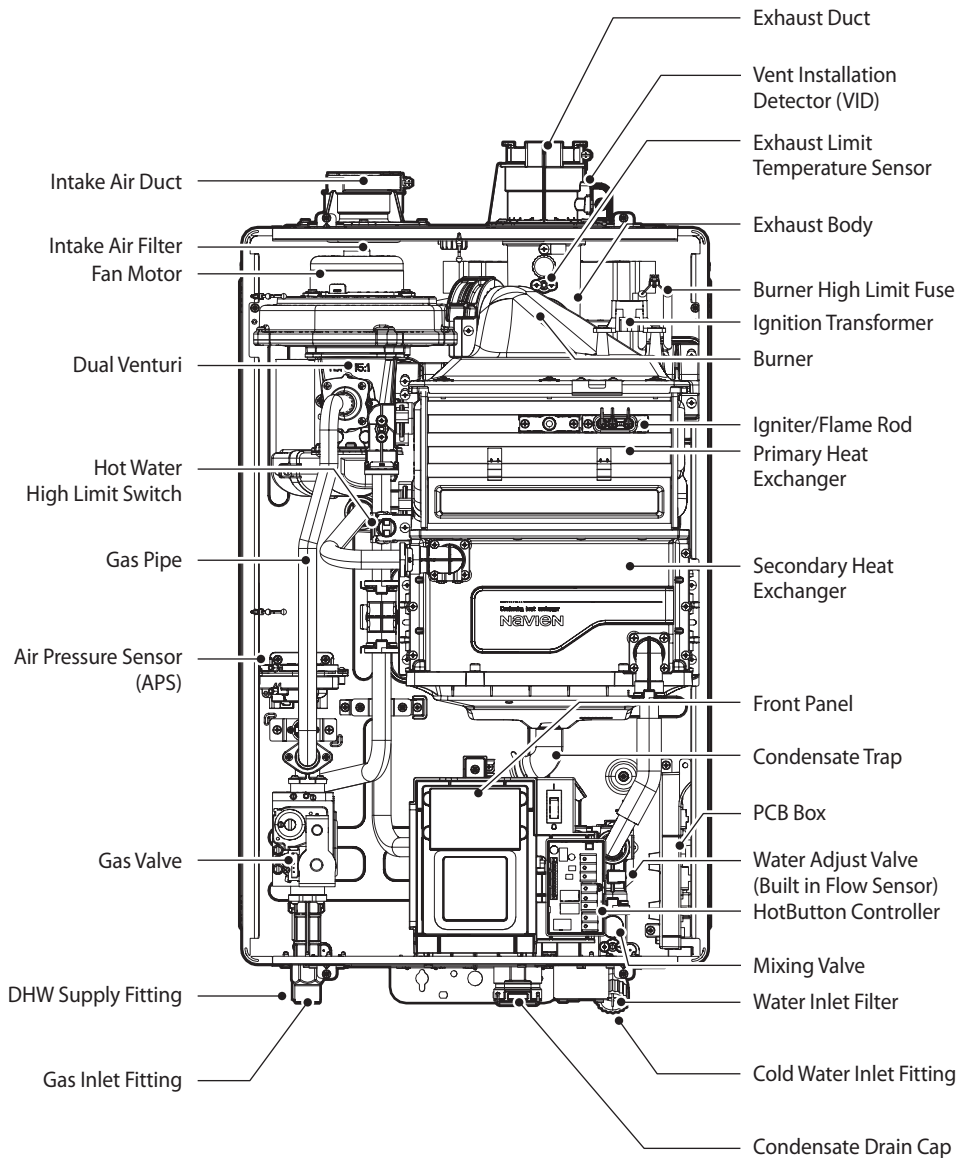

**[NPE-180S2/ 210S2/ 240S2]**

## 2.6 Dimensions

The following diagrams show the dimensions of the water heater and the table lists the supply.

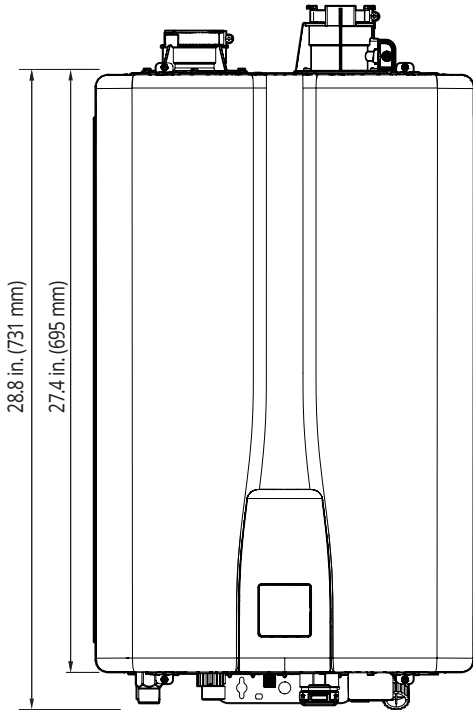

### Supply Connections

	Description	Diameter
A	Air Intake	2 in.
B	Exhaust Gas Vent	2 in.
C	Hot Water Outlet	¾ in.
D	Gas Inlet	¾ in.
E	Recirculation Inlet	¾ in.
F	Condensate Outlet	½ in.
G	Cold Water Inlet	¾ in.

### Overhead View

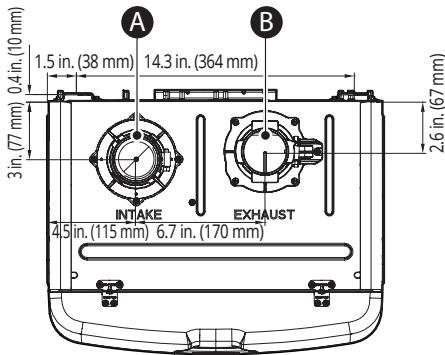

### Supply Connections

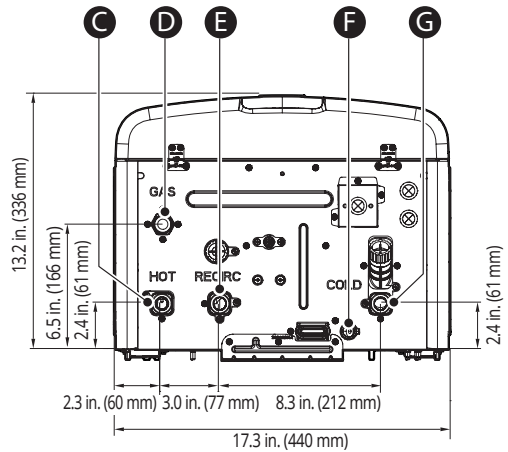

**[NPE-180A2/ 210A2/ 240A2]**

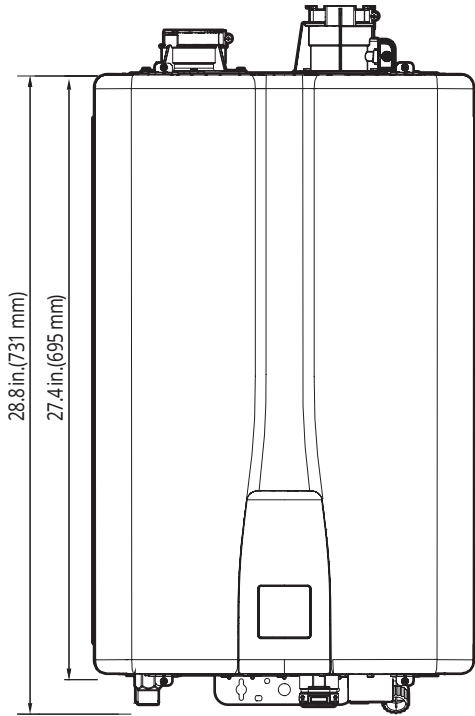

### Supply Connections

	Description	Diameter
A	Air Intake	2 in.
B	Exhaust Gas Vent	2 in.
C	Hot Water Outlet	¾ in.
D	Gas Inlet	¾ in.
E	Condensate Outlet	½ in.
F	Cold Water Inlet	¾ in.

### Overhead View

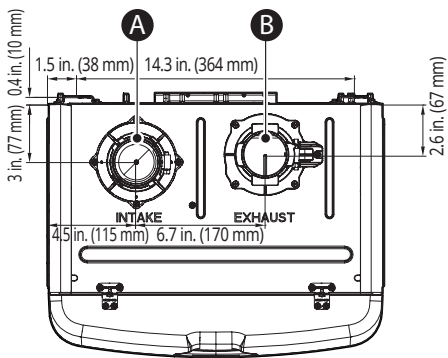

### Supply Connections

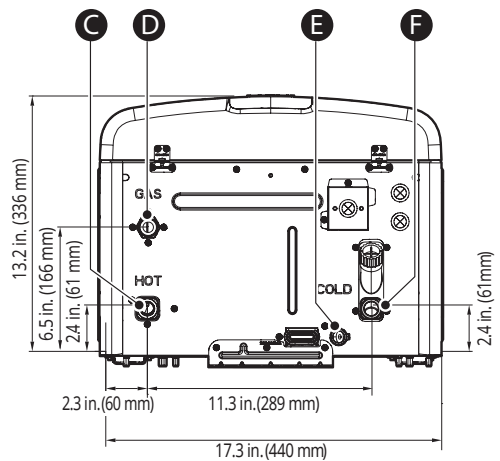

[NPE-150S2/180S2/210S2/ 240S2]

## 2.7 Rating Plate

Water heaters come from the factory configured for use with Natural Gas (NG). If conversion to Propane Gas is required, the included Propane Gas & High Altitude Conversion Kit must ALWAYS be used. Refer to the Propane Gas & High Altitude Conversion Guide for more information.

**Note** The Propane Gas & High Altitude Conversion Kit is attached to the interior of the water heater cabinet. You will need to remove the front cover to access the Propane Gas & High Altitude Conversion Kit. If you need assistance, please call a licensed professional or Navien Technical Support at 1-800-519-8794.

### **⚠ DANGER**

To prevent death, serious injury or property damage:

**Before starting the installation**, check the Rating Plate located on the side of the water heater to ensure that the water heater matches the gas type, gas pressure, water pressure, and electrical supply available in the installation location.

**If the water heater does not match each of these ratings, do not install the water heater.** Using a different gas type will result in abnormal combustion and malfunction of the water heater.

- ONLY a licensed professional should connect the gas supply.
- ALWAYS leak test the appliance and the gas connections before operating the appliance.
- This water heater cannot be converted from natural gas to propane without a Navien Propane Gas & High Altitude Conversion Kit. NEVER attempt a field conversion of this water heater without using the Navien Propane Gas & High Altitude Conversion Kit. Doing so will result in dangerous operating conditions and will void the warranty.

**Navien Inc. is not liable for any property damage, personal injury or death resulting from improper conversions.**

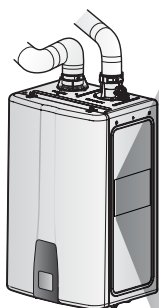

### Rating Plate, \*Plaque Signalétique

**Direct Vent Automatic Instantaneous Water Heater** \*Chauffe-eau instantané automatique à évent direct  
**For Indoor, Outdoor or Manufactured Home Installation** \*Pour une installation à l'intérieur, à l'extérieur ou dans une maison préfabriquée  
**FOR EITHER DIRECT VENT INSTALLATION OR FOR INSTALLATION USING INDOOR COMBUSTION AIR** (See manufacturer's installation instruction). \*POUR UNE INSTALLATION À ÉVENT DIRECT OU POUR UNE INSTALLATION AVEC AIR DE COMBUSTION INTÉRIEUR (Voir les instructions d'installation du fabricant).

Navien, Inc.  
 20 Goodyear, Irvine, CA 92618  
 Tel. 1-800-519-8794

Model No., \*Numéro de modèle  
 NPE-240A2

Max. Input Rating, \*Entrée GPL max.  
 199,900 Btu/h

Recovery Rating, \*Calibre de recouvrement

Max. Inlet Gas Pressure, \*Pression max. de gaz d'entrée

Min. Inlet Gas Pressure, \*Pression min. de gaz d'entrée

Manifold Pressure, \*Pression d'admission

Electrical Rating, \*Régime nominal électrique

Max. Water Pressure, \*Pression d'eau max.

Category of water heater, \*Catégorie de chauffe-eau

Type of Gas, \*Type de gaz

Natural Gas

Min. Input Rating, \*Débit calorifique max.

13,300 Btu/h

235 Gallons/Hour, \*gallons/heures

10.5 Inches W.C., \*pouces W.C.

3.5 Inches W.C., \*pouces W.C.

-0.96 Inches W.C., \*pouces W.C.

AC \*c.a. 120 Volts 60Hz, less than 2 amperes, \*Utilise moins de 2A

150 psi \*lipo<sup>2</sup>

Category IV CSA/ANSI Z21.10.3 · CSA 4.3-2019

Orifices necessary for Propane conversion are provided. \*Les injecteurs nécessaires à la conversion au GPL sont fournis.

Minimum ambient temperature at the installation location. \*Température ambiante minimale sur le lieu de l'installation 32 °F

Failure to use the correct gas can cause problems which can result in death, serious injury or property damage. \*Le fait de ne pas utiliser le bon gaz peut causer des problèmes qui peuvent mener à la mort, causer des blessures graves ou endommager la propriété.

Consult your installation manual for more information. \*Consultez votre manuel d'installation pour plus d'information.

Suitable for combination water (potable) heating and space heating and not suitable for space heating applications only.

\*Convient au chauffage combiné de l'eau (potable) et des locaux, mais non au chauffage des locaux seulement.

Suitable for commercial installations. \*Convenable pour installations commerciales.

This appliance is certified for use at altitudes up to 4,500 ft (1,370 m) in accordance to the latest CAN/CGA 2.17-High Altitude Installation

procedures at normal manifold pressure. This appliance has also been tested up to 10,100 ft (3,078 m). For installations at altitudes up to

10,100 ft (3,078 m), follow the directions provided in the High Altitude Installations sections of the Installation Manual.

\*Cet appareil est certifié pour une utilisation à des altitudes de 0 à 4 500 pieds (1 370 m) conformément aux toutes les procédures d'installation à

haute altitude CAN/CGA 2.17 à une pression normale. Cet appareil a été testé jusqu'à 10 100 pieds (3 078 m). Pour les instructions d'installation

à une altitude supérieure à 10 100 pieds (3 078 m), suivez les instructions fournies dans la section des installations à haute altitude du manuel d'installation.

This appliance must be installed in accordance with local codes, or in the absence of local codes, the National Fuel Gas Code, ANSI

Z223.1/NFPA 54 or the CSA B149.1, Natural Gas and Propane Installation Code. \*Cet appareil doit être installé selon les règlements locaux,

ou en l'absence de tels règlements, selon le National Fuel Gas Code, ANSI Z223.1/NFPA 54, ou les, Code d'installation du gaz naturel et du

propane, CSA-B149.1.

This appliance must be installed in accordance with the Manufactured Home Construction and Safety Standard, Title 24 CFR,

Part 3280 or the Canadian standard CSA Z240 MH Series, Manufactured Homes. \*Cet appareil doit être installé conformément à la

norme Manufactured Home Construction and Safety Standard, Title 24 CFR, Part 3 280 ou aux normes canadiennes de la série CSA

Z240 MH (maisons préfabriquées).

**FOR YOUR SAFETY \*POUR VOTRE SÉCURITÉ**

Do not store or use gasoline or other flammable vapors and liquids in the vicinity of this or any other gas appliances. \*Ne rangez

pas et n'utilisez pas d'essence ou d'autres liquides ou vapeurs inflammables près de cet appareil ou de tout autre appareil électroménager.



## 3. Installing the Water Heater

### 3.1 Choosing an Installation Location

When choosing an installation location, you must ensure that the location provides adequate clearance for the water heater, adequate venting and drainage options, and sufficient access to gas, water, and electrical supplies. Carefully consider the following factors when choosing an installation location:

#### **WARNING**

- Review all of the installation information in this manual before starting installation. Consider all the requirements for venting, piping, condensate removal, and wiring.
- Do not install this water heater in a recreational vehicle, trailer, boat or other moving vehicles as it will result in a Carbon Monoxide Poisoning Hazard.

**Note** If the water heater is installed in Massachusetts, see "Requirements for the State of Massachusetts" on page 140.

### About Water Quality

Proper maintenance of the water heater is required when water quality does not meet EPA standards. Damage caused by poor water quality is not covered under warranty. The following table shows the maximum contaminant levels allowed, based on the EPA National Secondary Drinking Water Regulations (40 CFR Part 143.3). If you suspect that your water is contaminated in any way, discontinue use of the water heater and contact an authorized technician or licensed professional.

Contaminant	Maximum Allowable Level
Total Hardness	Up to 200 mg/l (12 grains/gallon)
Aluminum	0.05 to 0.2 mg/l
Chloride	Up to 250 mg/l
Copper	Up to 1.0 mg/l
Iron	Up to 0.3 mg/l
Manganese	Up to 0.05 mg/l
pH	6.5 to 8.5
Sulfate	Up to 250 mg/l
Total Dissolved Solids (TDS)	Up to 500 mg/l
Zinc	Up to 5 mg/l
Chlorine	Up to 4 mg/l

If your local water is hard, please review the following recommended treatment and flushing guidelines.

Hardness Level		Treatment Method	Flush Frequency*
Soft	0-4 grains/gal (0-60 mg/L)	None	None
Moderately Hard	4-7 grains/gal (61-120 mg/L)	Water Softener** or Navien PeakFlow is Recommended	Once/Year
Hard	7-9 grains/gal (121-160 mg/L)	Water Softener** or Navien PeakFlow is HIGHLY Recommended	Residential: Once/Year Commercial: Twice/Year
Very Hard	9-12 grains/gal (161-200 mg/L)	Water Softener** or Navien PeakFlow is HIGHLY Recommended	
Extremely Hard	>12 grains/gal (200 mg/L)	Water Softener** or Navien PeakFlow is Required	

\* **Flushing is recommended if a treatment device is not installed.** This procedure should be performed using white vinegar or solutions that are specifically formulated for use on tankless water heaters. See page 116 in the Appendix for more information on flushing the heat exchanger.

\*\*Check local codes for any restrictions on use of water softeners.

## Access to Utilities

- Water – the installation location should be near where the domestic water supply enters the building.
- Gas – the installation location should be near where the gas supply enters the building.
- Electricity – the installation location should be near where the electrical supply enters the building.

## Humidity and Contact with Water

When installing the water heater, avoid places with excessive humidity. The water heater has electric gas ignition components. Moisture can get inside the water heater and damage the ignition system. The water heater must be installed in a way to ensure that the gas ignition system components are protected from water (dripping, spraying, rain, etc.) during operation and service.

## Adequate Drainage

The water heater produces a significant amount of condensate during operation. The water heater should be located near a suitable drain and where damage from a possible leak will be minimal.

**Note** Installing the water heater in a location without a drain will void the warranty and **Navien will not be responsible for water damages that occur as a result.**

For more information about condensate drainage, refer to “3.5 Connecting the Condensate Drain” on page 38.

The water heater must be located in an area where leakage of the unit or connections will not result in damage to the area adjacent to the appliance or to lower floors of the structure. When such locations cannot be found, installation of an adequately drained drain pan under the water heater is highly recommended. When installing the drain pan, ensure that the installation does not restrict combustion air flow.

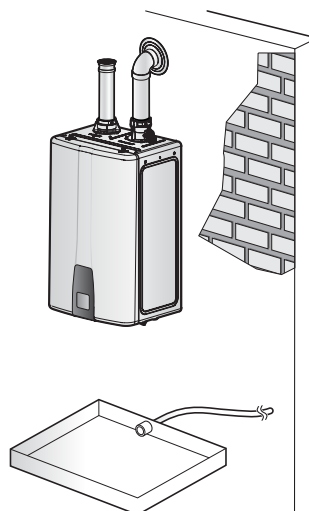

## Adequate Venting and Ventilation

Select a location that minimizes the length of the intake and exhaust vent piping. Consider venting restrictions caused by windows, doors, air intakes, gas meters, foliage, and other buildings. For more information about venting, refer to “3.6.1 Venting the Water Heater” on page 42.

To ensure adequate venting and ventilation, follow these guidelines:

- Maintain proper clearances from any openings in the building.
- Install the water heater with a minimum clearance of 12 in. (300 mm) above an exterior grade or as required by local codes.
- Do not enclose the vent termination.
- Install the exhaust vent in an area that is free from obstructions and does not allow the exhaust to accumulate.
- Do not install the water heater where moisture from the exhaust may discolor or damage walls.
- Avoid installations of the water heater in bathrooms, bedrooms, or any other occupied rooms that are normally kept closed or that are not adequately ventilated.
- Install a carbon monoxide detector in the dwelling area nearby the appliance. Refer to manufacturer’s instructions as well as the Consumer Product Safety Commission (CPSC) and Environmental Protection Agency (EPA) recommendations for proper use of carbon monoxide alarms.

## Proximity to Fixtures and Appliances

Install the water heater near fixtures that deliver or use hot water, such as bathroom, kitchen, and laundry room faucets. Select a location that minimizes the water piping required between major fixtures. If the distances are long or if the water heater requires “instant” hot water, we recommend running a recirculation line back to the water heater from the furthest fixture. Insulate as much of the hot water supply and recirculation lines as possible. For more information about the water supply, refer to “3.4 Connecting the Water Supply” on page 25.

## Adequate Installation Clearances

Install the water heater in an area that allows for service and maintenance access to utility connections, piping, filters, and traps. Based on the installation location, ensure the following clearances are maintained:

Clearance from:	Indoor Installation	Outdoor Installation
Top	9 in. (229 mm) minimum	36 in. (900 mm) minimum
Back	0.5 in. (13 mm) minimum	0.5 in. (13 mm) minimum
Front	4 in. (100 mm) minimum	24 in. (600 mm) minimum
Sides	3 in. (76 mm) minimum	3 in. (76 mm) minimum
Bottom	12 in. (300 mm) minimum	12 in. (300 mm) minimum

## Clean, Debris and Chemical-Free

### Combustion Air

- Do not install the water heater in areas where dust and debris may accumulate or where hair sprays, spray detergents, chlorine, or similar chemicals are used.
- Do not install the water heater in areas where gasoline or other flammables are used or stored.
- Ensure that combustible materials are stored away from the water heater and that hanging laundry or similar items do not obstruct access to the water heater or its venting.

#### **Note**

The combustion air must be free of flammable vapors or corrosive chemical fumes. Common corrosive chemical fumes to avoid include fluorocarbons and other halogenated compounds such as Freon, trichloroethylene, perchloroethylene, chlorine, all of which can be found in refrigerants or solvents. When these chemicals burn, they produce acids that corrode the stainless steel heat exchanger, gaskets, and the flue and vent system.

- In commercial locations, do not install the water heater in areas with greasy fumes or heavy amounts of steam or take measures to prevent fumes and steam from entering the water heater.

## High Altitude Installations

This unit may be installed at elevations up to 10,100 ft (3,078 m) for use with natural gas and propane gas. The Panel Setting should be set as described in "Setting Up the Altitude" on page 61.

Natural gas units require the use of a Natural Gas High Altitude Conversion Kit if installed at an elevation of 5,400 ft (1,646 m) or higher.

### WARNING

- ALWAYS read and follow the Natural Gas High Altitude Conversion Guide when installing the gas orifice included with the kit in order to prevent death, serious injury or property damage.
- The front cover will need to be removed from the water heater to access the High Altitude Conversion Kit.
- Do NOT install this water heater at elevations above 10,100 ft (3,078 m).

## Coastal Installations

For installations in sea or marine environments, the salty air can cause corrosion to the water heater. The water heater should be protected and enclosed to minimize exposure to the corrosive atmosphere. Damage due to a corrosive environment is not covered under warranty.

## Operating Temperature

The recommended ambient temperature at the installation location is above 32°F (0°C) and below 125°F (52°C).

**Note** Any damage to the water heater due to freezing temperatures will not be covered under the Navien Limited Warranty.

## 3.2 Mounting the Water Heater to the Wall

Navien water heaters come with an upper mounting bracket that is pre-drilled at 16 in. on center for easy installation on standard wall studs. If the strength of the wall is insufficient or if the framing is non-standard or uneven, reinforce the area before installing the water heater.

**Note** Avoid installation on common walls as the unit will make some operational noises while it is running.

### WARNING

- **The water heater is heavy.** Always lift the unit with assistance. Be careful not to drop the water heater while lifting or handling it to avoid bodily injury or damage to the unit.
- Install the water heater in the upright, vertical position. Installation in any other orientation will result in improper water heater operation and property damage, and could result in serious personal injury or death.

### **NOTICE**

- Ensure that the structure of the installation location is sturdy enough to support the full weight of the installed water heater, including the water contained in the heat exchanger and related piping.
- The wall must be vertical, and it must be capable of carrying the weight of the water heater.
- Do not mount the water heater to dry wall that has not been reinforced.
- **Do not** rest the water heater on the bottom end after removing it from the shipping carton. Doing so may result in excessive pressure on protruding pipes and cause product damage. If you must put the water heater down, lay it on its back or put it inside the protective shipping base.

To mount the water heater to the wall:

1. Drill holes into studs and drill holes into the drywall for plastic anchors. Insert anchors into drywall. Affix the bracket securely to the wall and ensure that it is level and that it can support the weight of the water heater.
2. Secure one screw to hold Wall Mounting Bracket. Check that the bracket is level then secure the remaining three screws.
3. With assistance from another person, lift the water heater slightly above hooks on the mounting bracket. Slowly lower until water heater is resting on the mounting bracket hooks. When mounted with the mounting bracket, the back of the water heater will have a  $\frac{5}{8}$  inch (16 mm) clearance from the wall.
4. Install two screws (not included) through the bracket at the bottom of the water heater to secure it to the wall.

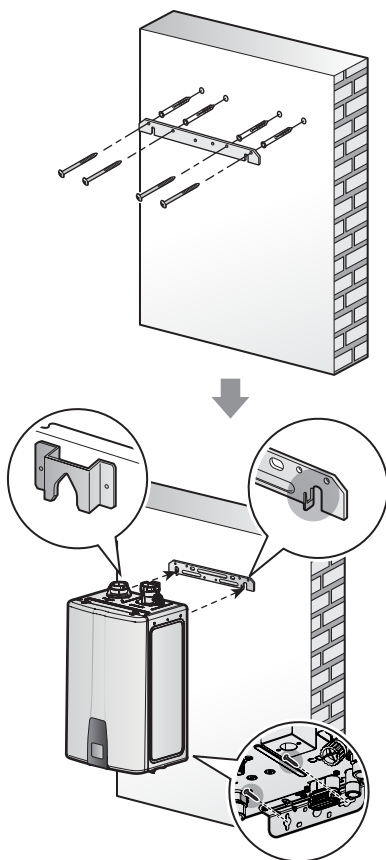

### 3.3 Connecting the Gas Supply

#### **! WARNING**

- **E773 - Improper Gas Type Detection Warning**

This error code activates when the unit detects a discrepancy between the gas type set during installation and the gas type connected to the unit. This function may not detect all abnormal gas connections and that the #1 DIP switch (Set of 8 Switches) setting must be verified on the unit before use. The unit may take some time to detect the gas type discrepancy as it depends on the gas flow rate and the exhaust outlet temperature. The error code may activate with the correct gas type and gas type setting due to varying measuring tolerances in the unit.

If the error code persists when the DIP switch setting matches the connected gas type, contact Navien Technical Support.

- Using a different gas type will result in abnormal combustion and malfunction of the product.

To prevent death, serious injury or property damage:

- ALWAYS check the Rating Plate located on the side of the product matches the gas type, gas pressure, water pressure, and electrical supply available for the unit.
- CHECK the #1 DIP switch setting on the Front panel matches the type of gas supplied to the unit (OFF for Natural Gas and ON for Propane Gas).

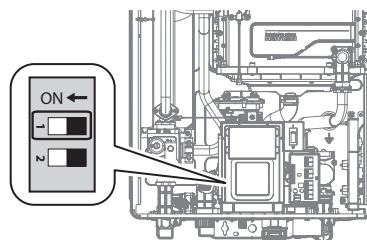

Switch	Function	Setting	
1	Gas Type	Natural Gas	OFF
		Propane Gas	ON

## **⚠ WARNING**

- Before connecting the gas supply, determine the gas type and pressure for the water heater by referring to the rating plate. Use only the same gas type indicated on the rating plate. Using a different gas type will result in abnormal combustion and malfunction of the water heater. Gas supplies should be connected by a licensed professional only.
- To avoid damaging the connectors on the water heater, use two wrenches when tightening pipings to the water heater. Use one wrench to prevent the connector at the water heater from turning, and use the other wrench to tighten the connection. Damaged connectors may result in system leaks.
- Properly support the piping with hangers. Do not allow the piping to be supported by the water heater or its accessories.
- Ensure that the gas piping is protected from physical damage and freezing, where required. Failure to follow these instructions could result in gas leakage, and result in fire, explosion, property damage, severe personal injury, or death.
- The appliance and its gas connection must be leak tested before placing the appliance in operation.
- To avoid danger from explosion and fire, do not use flame to check for a gas leak. Perform a bubble test on the joints to check for gas leaks. If a leak exists, bubbles will form at the leaking joint. A gas leak could result in substantial property damage, severe personal injury, or death.
- This water heater cannot be converted from natural gas to propane or vice versa without a Navien gas conversion kit. Do not attempt a field conversion of this water heater without a Navien gas conversion kit. Doing so will result in dangerous operating conditions and will void the warranty.

### **Note**

The Gas Conversion Kit is located inside the water heater cabinet. You will need to remove the front cover to access the Propane Gas & High Altitude Conversion Kit.

Navien recommends connecting the water heater as the first water heater downstream of the gas meter, to ensure a sufficient gas supply.

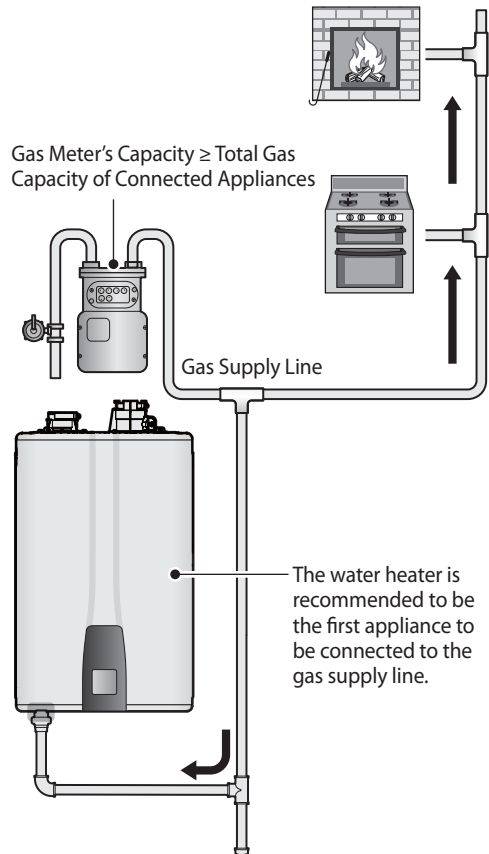

To connect the gas supply:

1. Determine the gas type and pressure for the water heater by referring to the rating plate.
2. Perform a pressure test on the main gas supply line.
3. Purge the gas line of any debris.
4. Determine the proper size and type for the gas line. Refer to the tables that follow.
5. Install certified full shut-off valves on the gas supply line and water heater.
6. Connect the gas supply line.
7. Test the supply line, all connection points, and the water heater for gas leaks.
8. Refer to the gas regulator manufacturer or local codes for recommended distances from the regulator to the appliance.

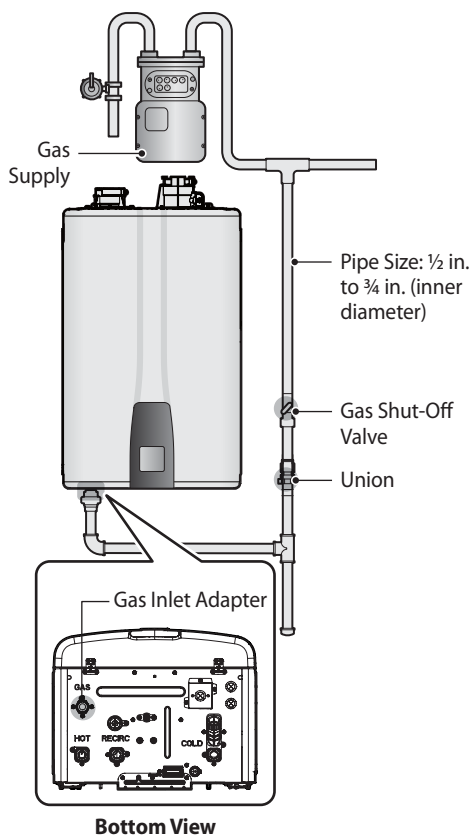

**Note**

- Tighten the water heater connection valves with care to avoid damage.
- The gas connection fitting on all water heaters is 3/4 in.
- 1/2 in. rigid pipe can be used; refer to the sizing tables on the preceding pages for limitations. DO NOT use 1/2 in. corrugated connectors or tubing as noise may occur.

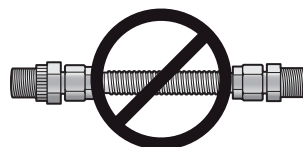

[Corrugated Connector]

- When using flexible gas lines, ensure that the pipe's inner diameter and connector is sufficient to supply the required BTUs. Also, ensure that the flexible line has no crimps or tight bends in it, as this will restrict gas flow.
- When using rigid pipe, Navien recommends the installation of a union on the gas supply line close to the water heater, to facilitate any future maintenance or service.
- Check with the local jurisdiction to verify whether the use of 1/2 in. gas pipe is approved in the area.

## NOTICE

Prior to using an excess flow valve (EFV) in the gas line, check the manufacturer's minimum and maximum flow capacity rating. An improperly sized EFV will not allow for a full flow of gas to the water heater and may cause improper operation.

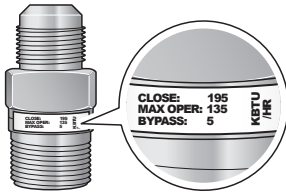

Excess Flow Valve

Typical Propane Gas piping examples:

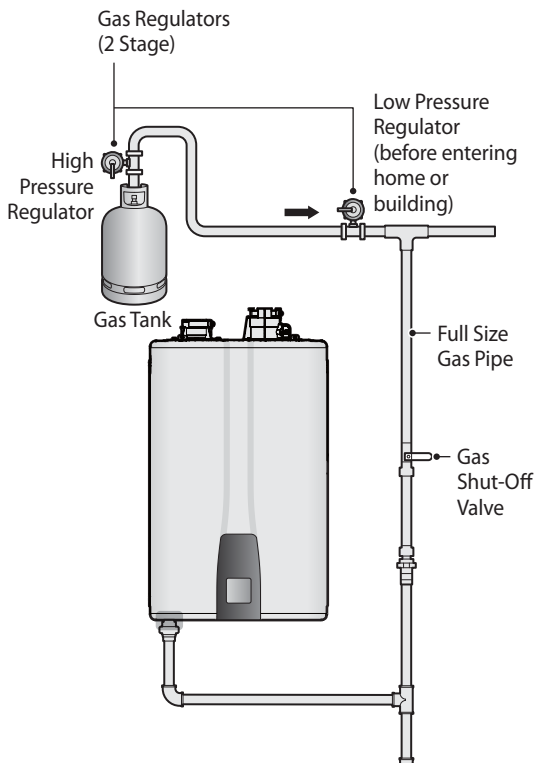

[2 Stage System with Multiple Regulators (Recommended)]

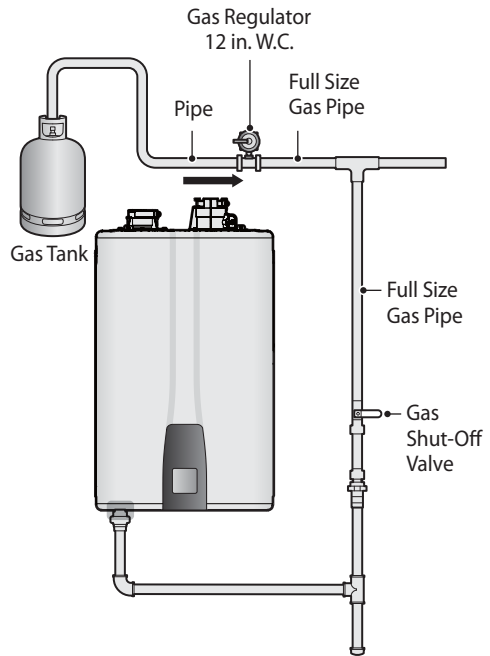

[Single Regulator System]

### Note

If installation requires the use of gas pressure regulators, follow all regulator manufacturers requirements and recommendations for sizing and proper installation.

### 3.3.1 Gas Pipe Sizing Tables (Referenced from Current National Fuel Gas Code)

These tables are for reference only. Please consult the gas pipe manufacturer for actual pipe capacities.

#### Maximum Natural Gas Delivery Capacity

In Cubic Feet (ft<sup>3</sup>) per Hour (0.60 Specific Gravity; 0.5 in. WC Pressure Drop). Contact your gas supplier for BTU/ft<sup>3</sup> ratings. Use 1,000 BTU/ft<sup>3</sup> for simplified calculations. This table is recommended for supply pressures less than 6 in. WC.

Pipe Size	Length (including fittings)										
	10 ft (3 m)	20 ft (6 m)	30 ft (9 m)	40 ft (12 m)	50 ft (15 m)	60 ft (18 m)	70 ft (21 m)	80 ft (24 m)	90 ft (27 m)	100 ft (30 m)	125 ft (38 m)
¾ in.	360	247	199	170	151	137	126	117	110	104	92
1 in.	678	466	374	320	284	257	237	220	207	195	173
1 ¼ in.	1,390	957	768	657	583	528	486	452	424	400	355
1 ½ in.	2,090	1,430	1,150	985	873	791	728	677	635	600	532
2 in.	4,020	2,760	2,220	1,900	1,680	1,520	1,400	1,300	1,220	1,160	1,020
2 ½ in.	6,400	4,400	3,530	3,020	2,680	2,430	2,230	2,080	1,950	1,840	1,630
3 in.	11,300	7,780	6,250	5,350	4,740	4,290	3,950	3,670	3,450	3,260	2,890
4 in.	23,100	15,900	12,700	10,900	9,660	8,760	8,050	7,490	7,030	6,640	5,890

In Cubic Feet (ft<sup>3</sup>) per Hour (0.60 Specific Gravity; 3.0 in. WC Pressure Drop). Contact your gas supplier for BTU/ft<sup>3</sup> ratings. Use 1,000 BTU/ft<sup>3</sup> for simplified calculations. This table is recommended for supply pressures of 6 in. WC or greater.

Pipe Size	Length (including fittings)										
	10 ft (3 m)	20 ft (6 m)	30 ft (9 m)	40 ft (12 m)	50 ft (15 m)	60 ft (18 m)	70 ft (21 m)	80 ft (24 m)	90 ft (27 m)	100 ft (30 m)	125 ft (38 m)
½ in.	454	312	250	214	190	172	158	147	138	131	116
¾ in.	949	652	524	448	397	360	331	308	289	273	242
1 in.	1,787	1,228	986	844	748	678	624	580	544	514	456
1 ¼ in.	3,669	2,522	2,025	1,733	1,536	1,392	1,280	1,191	1,118	1,056	936
1 ½ in.	5,497	3,778	3,034	2,597	2,302	2,085	1,919	1,785	1,675	1,582	1,402
2 in.	10,588	7,277	5,844	5,001	4,433	4,016	3,695	3,437	3,225	3,046	2,700
2 ½ in.	16,875	11,598	9,314	7,971	7,065	6,401	5,889	5,479	5,140	4,856	4,303
3 in.	29,832	20,503	16,465	14,092	12,489	11,316	10,411	9,685	9,087	8,584	7,608
4 in.	43,678	30,020	24,107	20,632	18,286	16,569	15,243	14,181	13,305	12,568	11,139

## Maximum Liquefied Propane Delivery Capacity

In Thousands of BTU/H (0.5 in. WC Pressure Drop)

Pipe Size	Length (including fittings)												
	10 ft (3 m)	20 ft (6 m)	30 ft (9 m)	40 ft (12 m)	50 ft (15 m)	60 ft (18 m)	80 ft (24 m)	100 ft (30 m)	125 ft (38 m)	150 ft (45 m)	175 ft (53 m)	200 ft (60 m)	250 ft (76 m)
½ in.	291	200	160	137	122	110	101	94	89	84	74	67	62
¾ in.	608	418	336	287	255	231	212	197	185	175	155	140	129
1 in.	1,150	787	632	541	480	434	400	372	349	330	292	265	243
1 ¼ in.	2,350	1,620	1,300	1,110	985	892	821	763	716	677	600	543	500
1 ½ in.	3,520	2,420	1,940	1,660	1,480	1,340	1,230	1,140	1,070	1,010	899	814	749
2 in.	6,790	4,660	3,750	3,210	2,840	2,570	2,370	2,200	2,070	1,950	1,730	1,570	1,440

### 3.3.2 Measuring the Inlet Gas Pressure

#### **⚠ WARNING**

The water heater cannot function properly without sufficient inlet gas pressure. Measuring the inlet gas pressure should be performed by a licensed professional only.

- The inlet gas pressure must be maintained between 3.5 in. and 10.5 in. WC for natural gas and between 8.0 in. and 13 in. WC for liquefied propane.
- The appliance and its individual shutoff valve must be disconnected from the gas supply piping system during any pressure testing of that system at test pressures in excess of ½ psi (3.5 kPa). The appliance must be isolated from the gas supply piping system by closing its individual manual shutoff valve during any pressure testing of the gas supply piping system at test pressures equal to or less than ½ psi (3.5 kPa).

#### **Note**

If gas pressure is out of the acceptable range or an excessive pressure drop is observed, contact the gas supplier or a qualified installer to supply proper gas pressure to the unit.

To measure the inlet gas pressure:

1. Shut off the manual gas shut-off valve on the gas supply line.

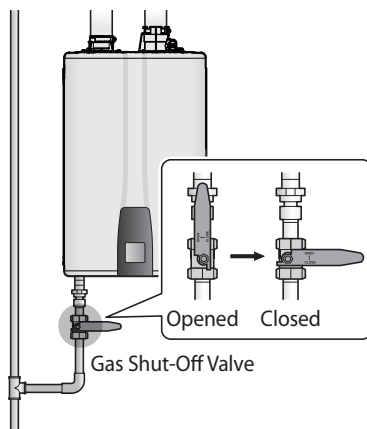

- Open a hot water faucet. The water heater should turn on and the gas in the gas supply line will be purged.
- Leave the faucet on until the water heater shuts down due to a lack of gas supply, and then turn off the hot water faucet.
- Remove the water heater front cover by loosening the 4 Phillips head screws securing it to the case.

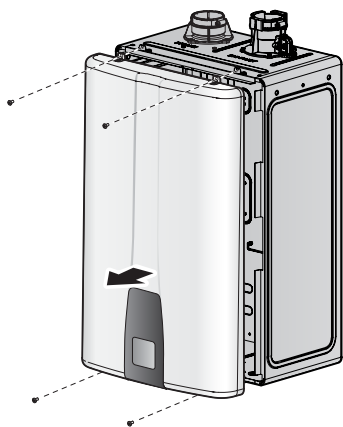

- Loosen the screw indicated in the figure below and connect a manometer to the pressure port. Reset the manometer to zero before use.

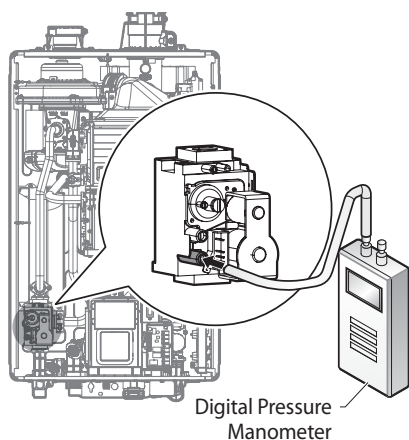

- Re-open the manual gas shut-off valve and check for leaks.
- Open multiple fixtures that have high flow rates, such as bathtub and shower faucets, to ramp the water heater up to its maximum firing rate.

- When the water heater reaches its maximum firing rate, check the inlet gas pressure reading on the manometer. The gas pressure must fall within the ranges specified on page 24.

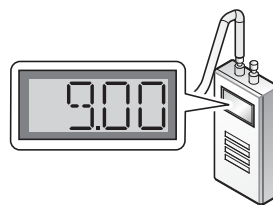

### 3.4 Connecting the Water Supply

The water fittings on the water heater are  $\frac{3}{4}$  in. If the installation site only has  $\frac{1}{2}$  in. plumbing throughout, it is not necessary to upsize the water lines to  $\frac{3}{4}$  in, if you are installing a single water heater. When installing multiple water heaters, the number of water heaters and pipe sizing required will depend on the total hot water demand. For information about pipe sizing for multiple water heaters, refer to "4.6.1 Initially Setting the Multi Remote Controller System" on page 65.

#### Note

Using  $\frac{1}{2}$  in. water lines may reduce the overall flow rate of the system and overall capability of the water heater.

When connecting the water supply, follow these guidelines:

- Do not remove the factory installed recirculation inlet cap unless a return line is connected to this fitting. Water leakage will occur if this cap is loose or missing ("A2" model only).
- Use only pipes, fittings, valves, and other components, such as solder, that are approved for use in potable water systems.
- Tighten the water heater connection valves with care to avoid damage.
- We recommend using unions and manual shut-off valves on the cold water inlet, DHW outlet, and recirculation water inlet.
- Strive to make the hot water piping system as short as possible, to deliver hot water to the fixtures more quickly.

- To conserve water and energy, insulate all water piping—especially the hot and recirculation water lines. Never cover the drain or pressure relief valve. If the water heater is installed in a closed water supply system, such as one having a backflow preventer in the cold water supply line, means shall be provided to control thermal expansion. Contact the water supplier or local plumbing inspector for information about how to control this situation.
- After installing the water heater, clean the inlet water filter that is located inside the cold water inlet, and then test the water heater for proper flow and inspect for leaks. Instruct the water heater owner that the filter must be cleaned periodically to maintain proper water flow.

**Note**

The following is a typical water piping example for NPE-180A2/210A2/240A2 models and is for reference only.

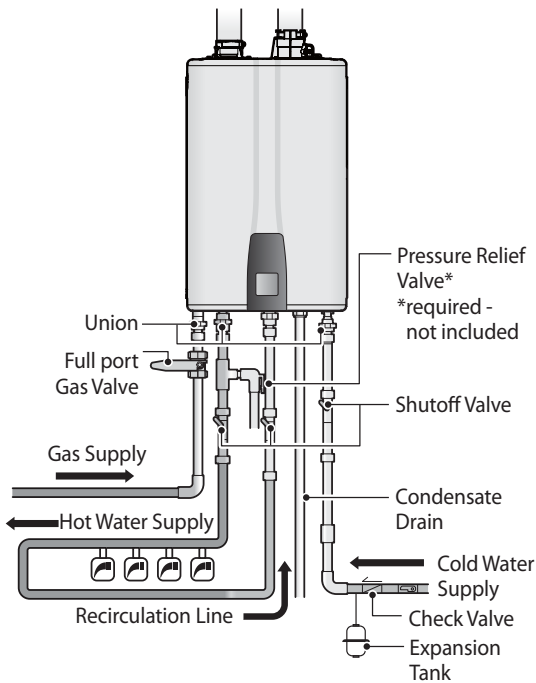

**[NPE-180A2/ 210A2/ 240A2]**

**Note**

The following is a typical water piping example for NPE-150S2/180S2/210S2/240S2 models and is for reference only.

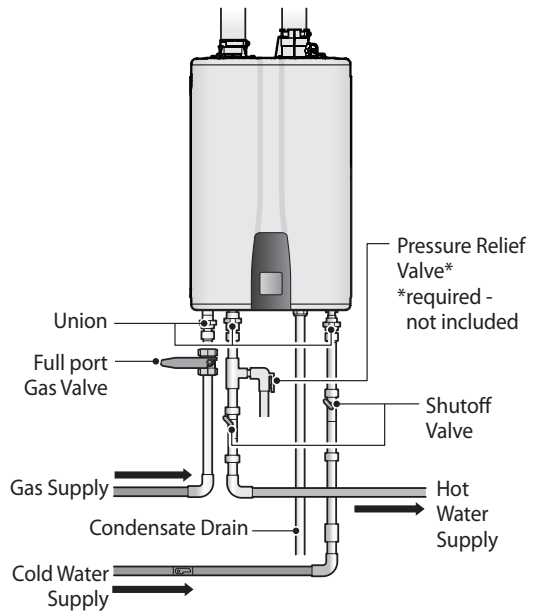

**[NPE-150S2/180S2/ 210S2/ 240S2]**

### 3.4.1 Using the Water Heater for Combination Water Heating and Space Heating

When using the water heater for both water (potable) heating and space heating, follow these guidelines:

- Ensure that all piping and components connected to the water heater are suitable for potable water applications.
- Do not introduce toxic chemicals, such as water heater treatments, into the potable water.
- On Combi applications, circulators suitable for DHW applications must be used.
- Do not connect the water heater to any heating systems or components that have been previously used with non-potable water heaters.
- If the system requires varying temperatures for water—for example, hotter water for space heating than for other uses—a mixing valve is required to temper the water and reduce the potential for scalding.
- Do NOT use the water heater only for space heating.
- Make sure circulator flow rate through the Water Heater does not exceed 4 GPM.

#### Note

- Do not configure the system for DHW recirculation when it is configured to run an air handler using the H2Air add-on controller. DHW recirculation and Navien H2Air configurations cannot be used at the same time.
- Water heaters used for space heating only will not be covered under the Navien Limited Warranty.

### 3.4.2 Selecting a Recirculation Mode ("A2" Model Only)

On all "A2" model Navien water heaters, you can choose from two pre-heating modes: internal recirculation mode or external recirculation mode. To select a recirculation mode, you must adjust the recirculation settings on the front panel and set the position of the 2-way valve inside the water heater. Refer to "Included Items" on page 80.

When the optional ComfortFlow recirculation mode is activated, energy consumption increases because the water heater operates to maintain the water temperature within the circulation loop. You can use the Navien Intelligent Preheating feature, set the weekly timer, or activate the HotButton feature (additional accessories required) to reduce energy consumption.

The recirculation feature of the "A2" models has three performance advantages:

- Lower Minimum Flow Rate is needed to produce hot water.
- Resolves hot/cold/hot stacking issue—the "cold water sandwich" effect.
- Quicker hot water delivery to fixtures, which results in less water wasted.

#### Note

When using external recirculation mode with the built-in pump, observe the following maximum recirculation pipe lengths including fittings ( $\frac{3}{4}$  in. pipe is recommended):

- $\frac{1}{2}$  in. Copper Pipe-100 ft (30 m) of equivalent length
- $\frac{3}{4}$  in. Copper Pipe-500 ft (150 m) of equivalent length

Lengths in excess of these limits will require an external recirculation pump.

If PEX is used for the water piping, consult with the pipe and fittings manufacturer for sizing and equivalent pressure drop information.

## Internal Recirculation Mode ("A2" Model Only)

To use the internal recirculation mode:

1. Connect the water supply.
2. Set the 2-way valve inside the water heater to "INT."

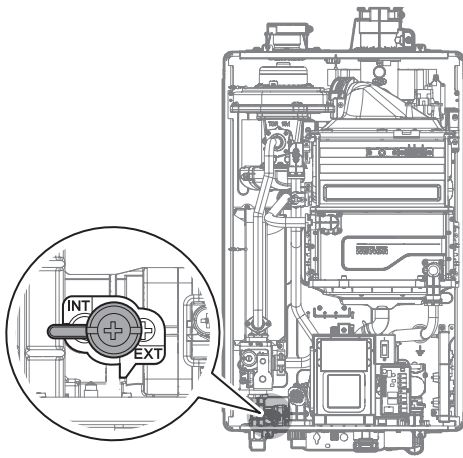

3. Press the Menu button (M) to access the Main menu and select **1. Recirculation Setting** > **3. Internal Recirculation** by pressing the OK button (OK).

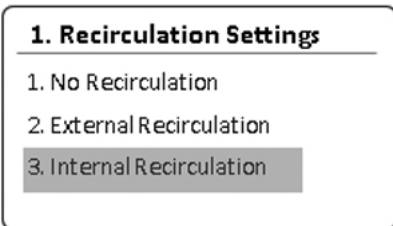
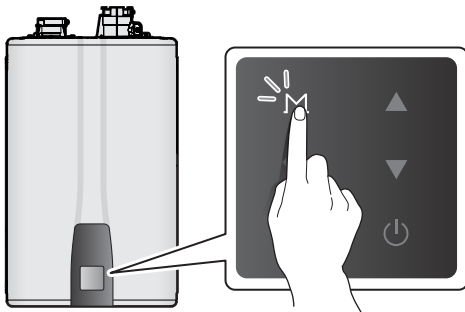

### Note

- For more information about the Recirculation settings, refer to "Included Items" on page 80.
- Internal Recirculation is available only on A2-type models.

Model	Step 1	Step 2	Step 3
A2-type	Int. Recirc	Always On	N/A
		Intelligent	N/A
		Weekly	Schedule Set

### NOTICE

Do not remove the cap on the recirculation inlet fitting if the Internal Recirculation Mode is used.

The following diagram shows the internal recirculation flow for pre-heating:

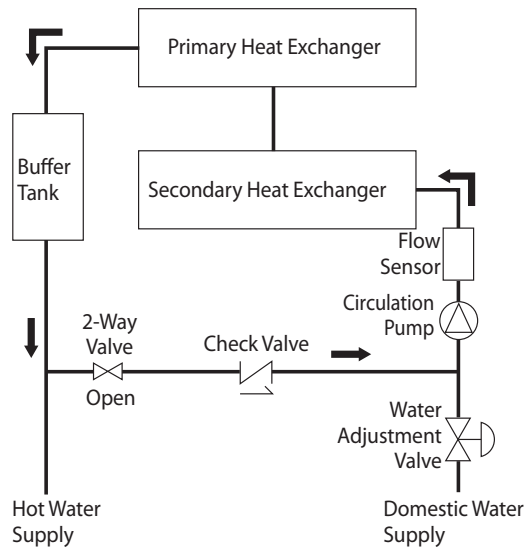

[Internal Recirculation Mode]

## External Recirculation Mode

To use the external recirculation mode:

1. Connect the water supply to support recirculation. Refer to the "[NPE-180A2/ 210A2/ 240A2]" diagram on page 26.
2. Set the 2-way valve inside the water heater to "EXT."

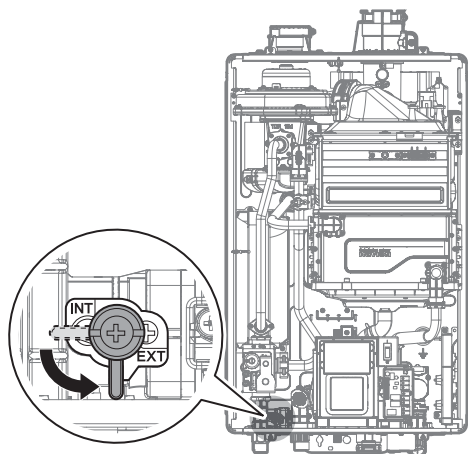

3. Press the Menu button (M) to access the Main menu and select **1. Recirculation Setting** > **2. External Recirculation** by pressing the OK button (OK).

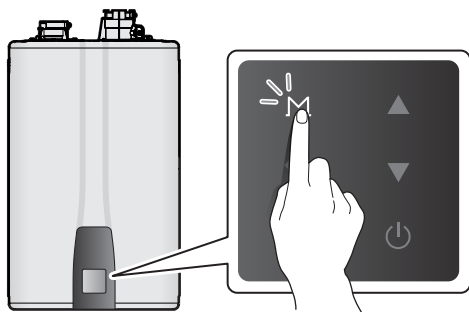

### 1. Recirculation Settings

1. No Recirculation
2. External Recirculation
3. Internal Recirculation

### Note

- For more information about the Recirculation settings, refer to "Included Items" on page 80.
- If the A2-type model requires an external pump, follow the instructions in "3.4.3 External Pump Wire Connection" on page 30 first and select **YES** on the screen asking whether the external pump is connected to the PCB.

Model	Step 1	Step 2	Step 3
A2-type	Ext. Recirc	Use Ext. Pump Yes/No	Always On
			Intelligent
			Weekly
			HotButton
S2-type	Ext. Recirc	Always On	N/A
			Intelligent
			Weekly
			HotButton
			Schedule Set
			N/A

The following diagram shows the external recirculation flow for pre-heating:

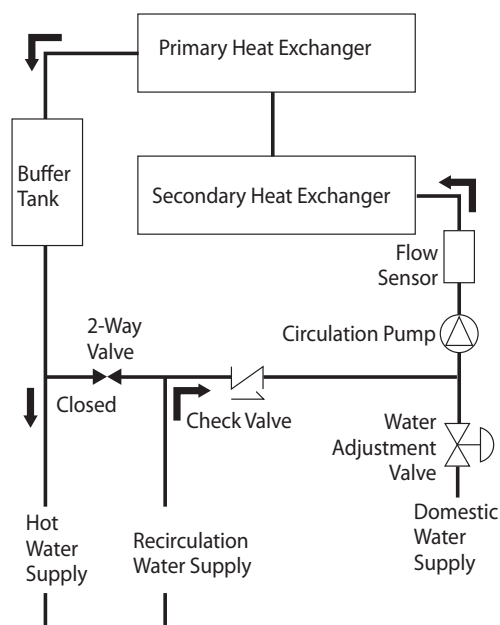

[External Recirculation Mode using the Recirculation Inlet]

### 3.4.3 External Pump Wire Connection

An external pump may be connected to the water heater for recirculation applications. When selecting a circulator, it shall be sized to maintain a flow of 2-4 GPM through the water heater. Follow the instructions below when connecting the pump wire accessory to the PCB.

#### **⚠ WARNING**

##### **Electric Shock Hazard**

To prevent death, serious injury, or property damage:

- DO NOT remove the front cover unless the power to the water heater is turned off or disconnected.
- ALWAYS check the water heater is turned off before connecting the wire to the PCB.

#### **Note**

Configure the desired mode according to the instructions in this manual.

#### <Specifications>

- External Pump Wire (#GXXX001319)
  - Maximum Power Consumption: 150 W, 1.5 A
  - Length: 6 ft (183 cm)
- ※ When using a pump with larger power requirements than the listed specification above, a relay should be used to ensure proper operation.

1. Remove the water heater front cover by loosening the 4 Phillips head screws securing it to the case.

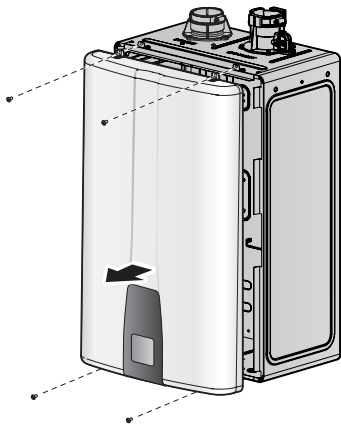

2. Locate the power switch on the right side of the front panel and switch the system off.

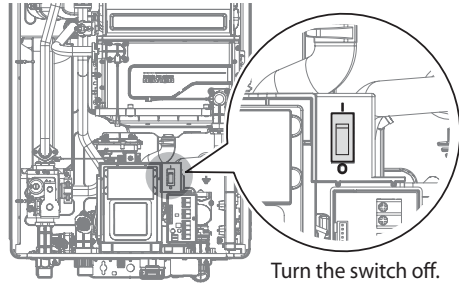

3. Remove the 2 screws holding the PCB box in place and remove the PCB box from the system.

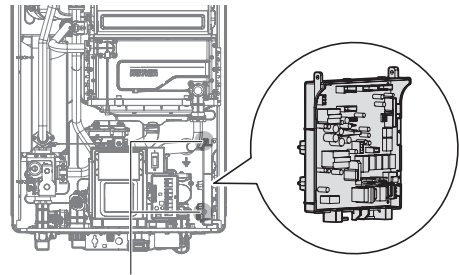

4. Connect the external pump wiring connector to the connector socket on the PCB (TB1).

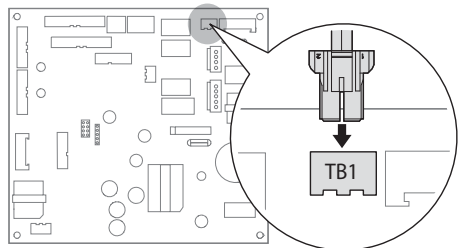

5. Put the PCB box back in its original place and secure it using the 2 mounting screws.
6. Remove the plastic insulation from the external pump wire with a wire stripper before connecting it to the pump.

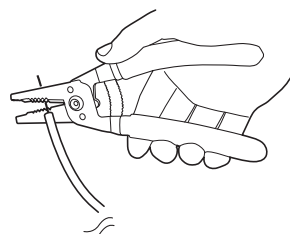

- Connect the external pump wire to the proper wires from the pump junction box.

## ⚠ WARNING

ONLY turn on the water heater after connecting the wire to the external pump to prevent serious injury or death from electric shock.

- Turn on the switch beside the front panel.
- Put the water heater cover back on and secure it with the 4 screws.  
You can configure it as either Type 1 or Type 2 if you install an external recirculation line.

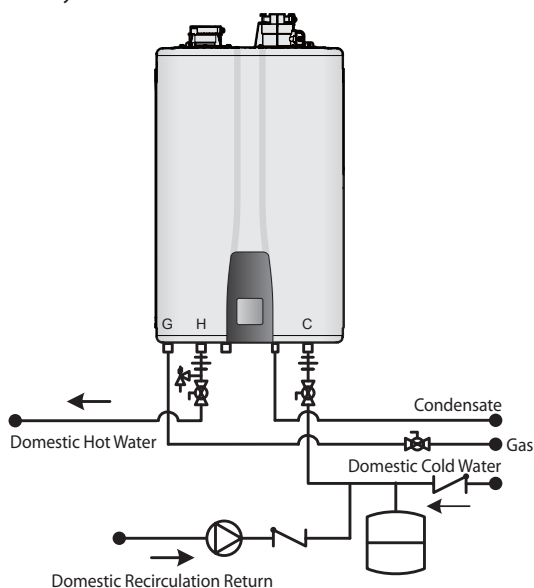

**[Type 1. Recirculation using External Pump - Return line ties into Cold Water Inlet (NPE-S2 Models)]**

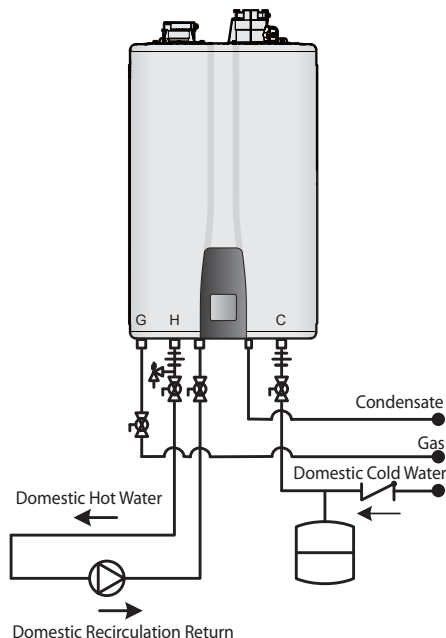

**[Type 2. Recirculation Using a Second Pump (NPE-A2 Models, Navien Internal Pump & External Pump)]**

### 3.4.4 Navien HotButton Kit

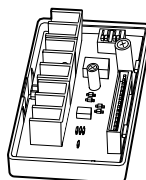

The NPE-A2/S2 series water heaters have a built-in Navien HotButton controller (the push button, wall plate, and temperature sensor have to be purchased separately). It adds signal input functions to the NPE-A2/S2 series water heaters for more efficient DHW hot water recirculation functionality.

With the HotButton kit, DHW recirculation is carried out exactly when the actual demands arise. This prevents energy loss caused by unnecessary operation of the burner and pump throughout the day.

The HotButton kit can receive signals from multiple push buttons installed in various areas and performs optimal DHW recirculation only when there is a demand for hot water. For more information about the parameter settings, refer to "Included Items" on page 80, "6.8 Maintenance" on page 88, and "7.5.1.3 Setting the Application" on page 101.

## Included Item

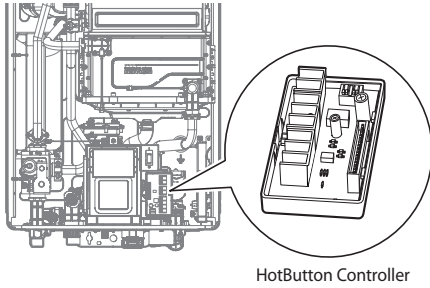

HotButton Controller

## Items Not Included



Push Button  
Switch  
(#GXXX001426)



Wall  
Plate  
(#GXXX001427)

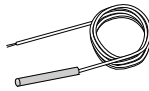

Temperature  
Sensor  
(#GXXX001640)

### Note

In addition to activating the HotButton using push buttons, recirculation can also be started through the NaviLink app if the optional NaviLink WiFi control system has been installed.

## Device Layout

Refer to the following diagram for the product layout.

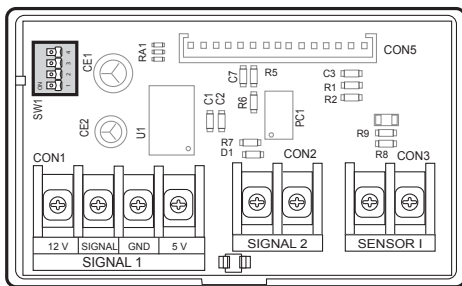

\* SIGNAL1 contacts are for optional wireless push buttons or motion sensor accessories.

\*\* SENSOR I contacts are connected with a piece of metal plate by default. Remove the metal plate before connecting a temperature sensor to the circuit board.

## Wiring Connection Table

Terminal	Wiring Connection	
Signal1	12 V	Contacts for wireless push button or motion sensor connection
	Signal	
	GND	
	5 V	
Signal2 (Not polarity sensitive)	Push Button Switch Contact #1	
	Push Button Switch Contact #2	
Sensor I	Contacts for temperature sensor connection	

## Connecting Wired Switches

Refer to the following diagrams to connect a wired switch, or multiple wired switches to the HotButton controller.

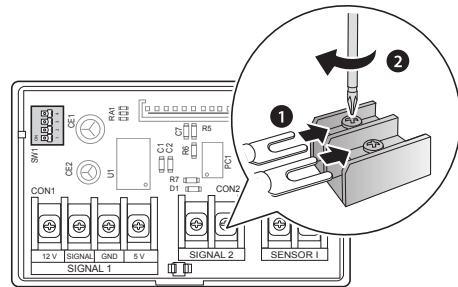

### Note

- Multiple wired switches may be connected to the same terminal contacts.
- Use spade connectors at the end of the cables to securely install the cables to the terminal contacts.

When you connect the push button switches to the controller, you can run cables from each switch directly to the controller and connect them to the same terminal. Or, you can run a common branch circuit that runs from the controller and connect each switch to the branch.

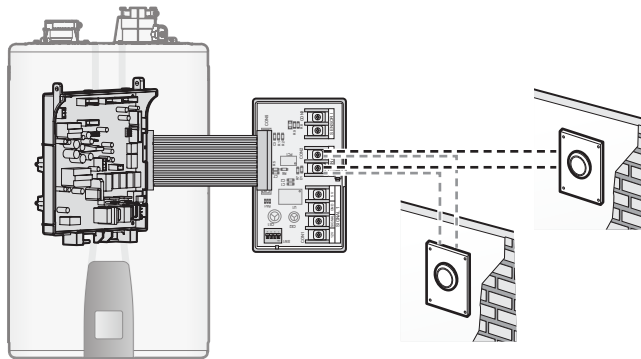

[Multiple switches connected directly to the same terminals at the controller]

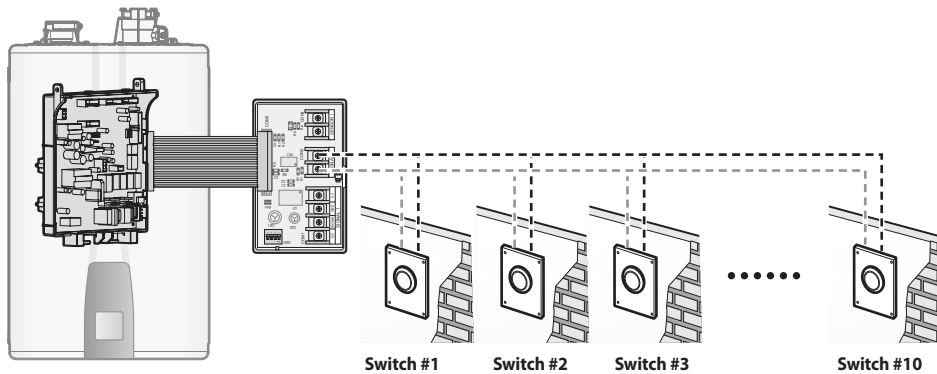

[Multiple switches connected to a common branch circuit]

**Note**

- You can connect up to 10 push button switches to one HotButton controller.
- Use UTP cables or cables with a diameter greater than AWG 24.
- Make sure that the total cable length does not exceed 328 feet (100 meters).
- Additional push button switches (#GXXX001426) and wall plates (#GXXX001427) can be purchased through Navien.

### HotButton DIP Switch Information

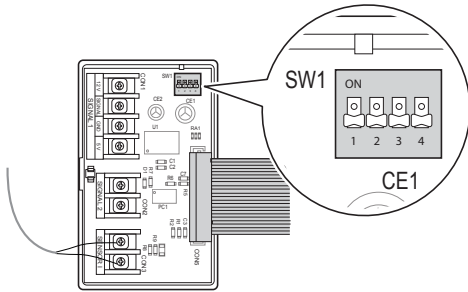

DIP SW	OFF	ON
1	Enable the HotButton.	Disable the HotButton.
2	Enable the energy saver function.	Disable the energy saver function.
3	Reserved	Reserved
4	Reserved	Reserved

**Note**

- HotButton DIP SW1
  - Enable or disable the HotButton function.
  - Default: Enabled (OFF)
- HotButton DIP SW2
  - Enable or disable the energy saver function.
  - Default: Enabled (OFF)
  - The energy saver function limits the operation time of the recirculation system to reduce energy usage. This function may be required to remain enabled to meet local building code regulations.

### 3.4.5 System Application - External Recirculation

The following diagram shows the recirculation system's basic operation of an NPE-A2/S2 series water heater system with the Navien NaviCirc and Navien HotButton kit with or without a dedicated return line.

**Note**

- The NPE-A2/S2 series water heaters have a built-in Navien HotButton controller (the push button, wall plate, and temperature sensor must be purchased separately).
- Install the NaviCirc to the faucet farthest from the water heater. If installed in close proximity to the water heater, faucet pipes far away may not be properly heated.
- For details, refer to the manual provided with the NaviCirc kit.
- The Navien HotButton can be used ONLY with a water heater system configured for DHW recirculation.
- All other recirculation functions will be disabled.

## External Recirculation with HotButton and NaviCirc

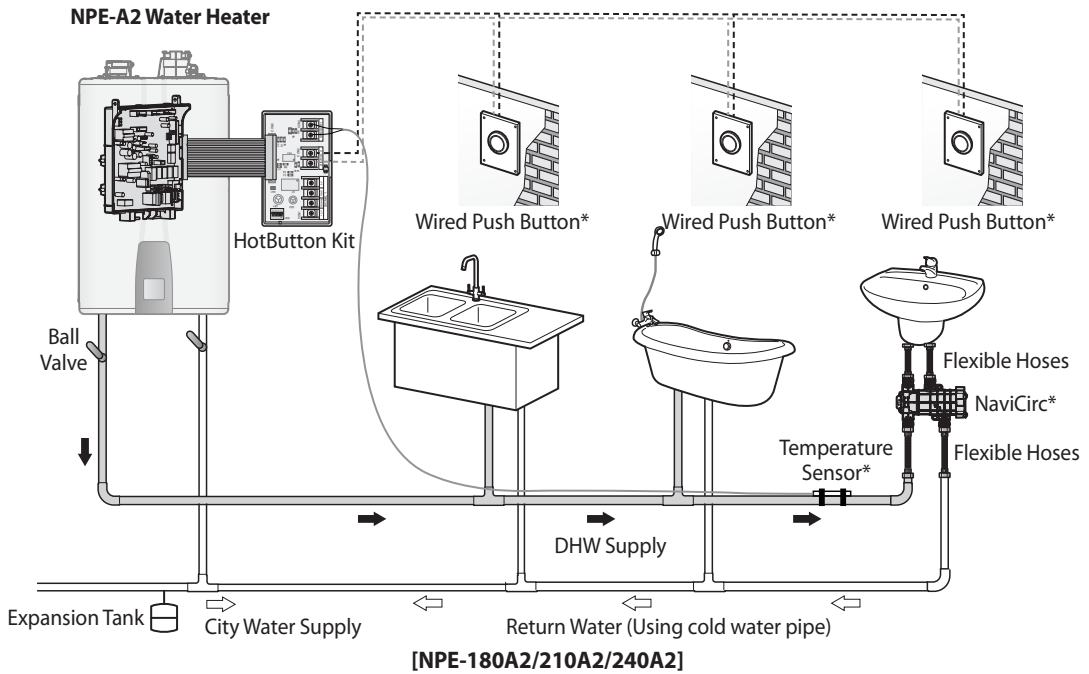

**Note**

- Set the 2-way valve inside the water heater to the "Ext" position when using the NaviCirc recirculation valve.
- It is not necessary to install bypass piping from the cold line to the recirculation inlet fitting for NPE-A2 models.

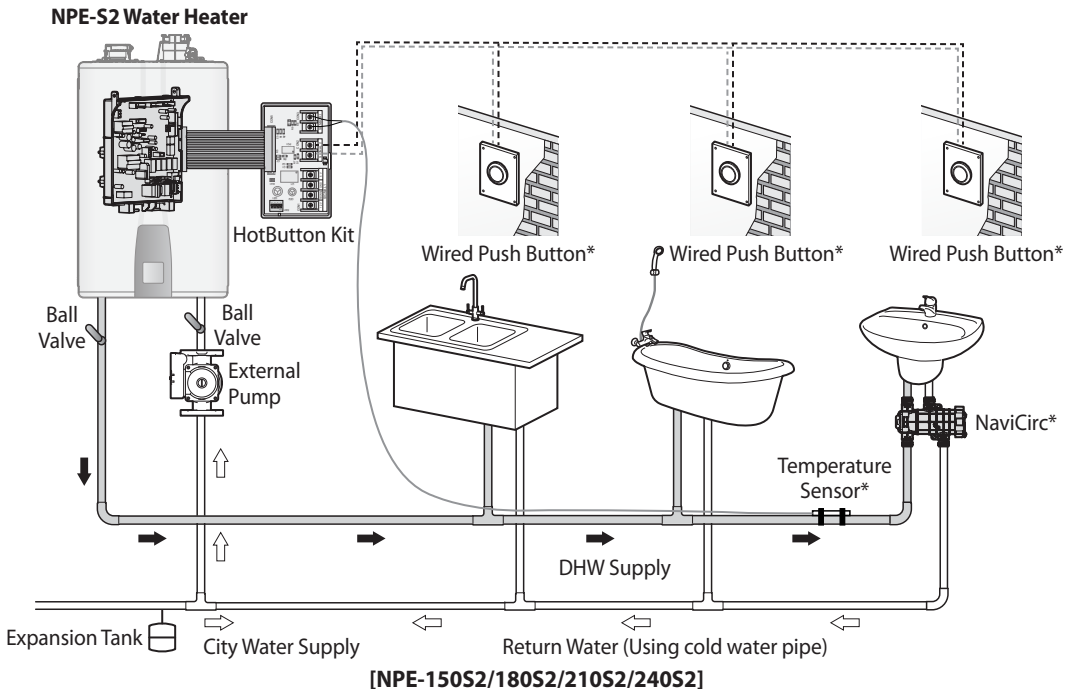

\*The NaviCirc recirculation valve, the push buttons, and the temperature sensor are not included with the water heater but are available for purchase.

**External Recirculation with HotButton and Dedicated Return Line**

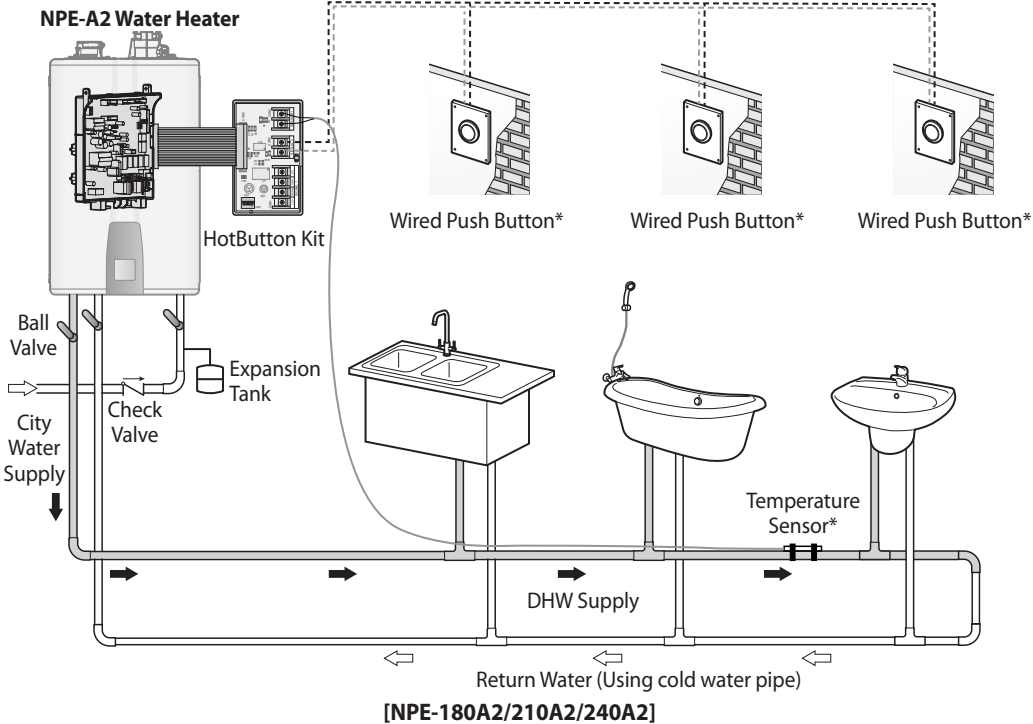

\*The push buttons and the temperature sensor are not included with the water heater but are available for purchase.

### 3.4.6 Connecting a Pressure Relief Valve

#### **⚠ WARNING**

- ONLY licensed professionals should install the pressure relief valve.
- ALWAYS follow all instructions and guidelines when installing the pressure relief valve. Improper installation of the pressure relief valve may result in death, serious injury, or property damage.
- The pressure relief valve is not supplied, but is required.

To complete the installation of the water heater, you must install an approved  $\frac{3}{4}$  in. maximum 150 PSI pressure relief valve on the hot water outlet. The water heater has a built-in high temperature shut off switch, so install a "pressure only" relief valve. This valve is not supplied, but is required. The following examples are approved for use with the water heater:

- Wilkins P-1000A (Zurn Industries)
- Conbraco 17-402-04
- Watts Industries 3L (M7)
- Cash Acme FWL-2,  $\frac{3}{4}$  in.

#### **Note**

The pressure relief valve should be placed as close to the water heater as possible. No other valve should be placed between the pressure relief valve and the water heater.

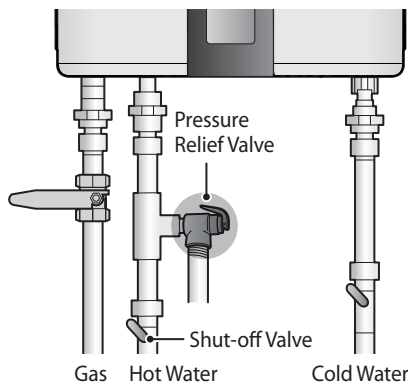

#### **⚠ WARNING**

To prevent scalding, burns and water damage, always route the discharge line to a safe location.

When installing the valve, follow these guidelines:

- Ensure that the discharge capacity of the pressure relief valve is equal to or greater than the maximum pressure rating of the water heater.
- Ensure that the maximum BTU/H rating on the pressure relief valve is equal to or greater than the maximum input BTU/H rating of the water heater.
- Direct the discharge piping of the pressure relief valve so that hot water will not splash on anyone or any nearby equipment.
- Attach the discharge line to the pressure relief valve with approved materials and run the end of the line to within 6 - 12 in. (150 - 300 mm) of the floor drain, making discharge clearly visible.
- Ensure that the discharge line will allow free and complete drainage without restriction. Do not install a reducing coupling or other restriction on the discharge line.
- Do not direct the discharge line to a location where freezing could occur.
- Ensure that the discharge line is not plugged or obstructed.
- After filling and pressurizing the system, test the relief valve operation by lifting the lever. If the valve fails to operate correctly, immediately replace the relief valve.
- If the relief valve discharges periodically, this may be due to thermal expansion in a closed water supply system. Contact the water supplier or local plumbing inspector on how to correct this situation. Do not plug the relief valve.

#### **⚠ WARNING**

- To prevent serious injury or death, the pressure relief valve should be checked at least once every three years by manually operating the relief valve.
- Before manually operating the valve, check the discharge line and discharge location to ensure you or others will not come in contact with hot water. Hot water can cause burns and may result in serious injury or property damage.

### 3.5 Connecting the Condensate Drain

The Navien Condensing Water Heater creates condensation when it operates. This condensation has an acidic pH of 3 - 5. Follow all local codes and regulations when disposing of condensate from the water heater. Check local codes for suitable waste drain locations if applicable.

#### **⚠ WARNING**

- Fill the condensate trap with water after installing the condensate drain pipe.
- Do not cap or plug the integrated condensate line. If prevented from draining, condensate can damage the water heater.
- The condensate line must have a negative slope to drain properly.
- NEVER drink or allow animals to drink condensate. The pH of the condensate could cause serious injury.

Before connecting the condensate drain, choose one of the following disposal options:

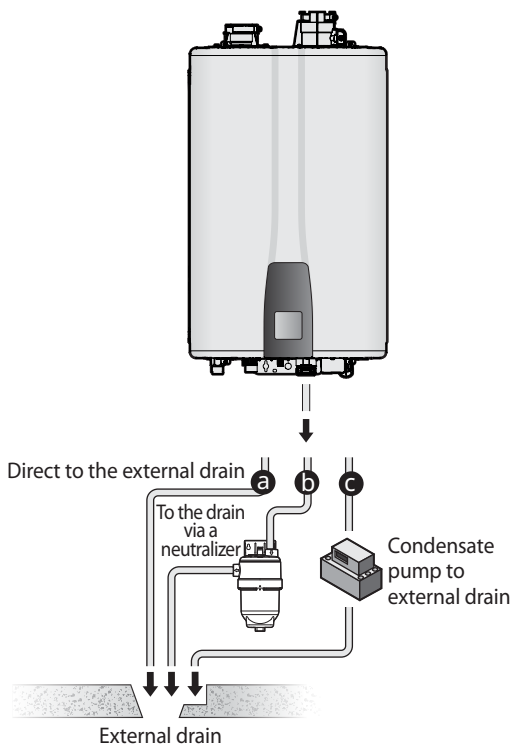

- From the water heater directly into an external drain.
- From the water heater, through a neutralizer agent, and then into an external drain.

**Note** If you choose this option, the neutralizer agent must be replaced periodically. Depletion of the neutralizer agent will vary, based on the usage rate of the water heater. During the first year of operation, the neutralizer should be checked every few months for depletion and replaced as needed.

- From the water heater into a condensate pump, and then into an external drain.

**Note** A pump can be used when there is a long distance between the water heater and the laundry tub or when the bottom of the water heater is lower than the top of the laundry tub.

To connect the condensate drain:

1. Connect a drain line to the ½ in. fitting at the bottom of the water heater.  
Use only corrosion-resistant material for the drain line, such as PVC or CPVC. Do not reduce the size of this fitting or the drain line to less than ½ in.

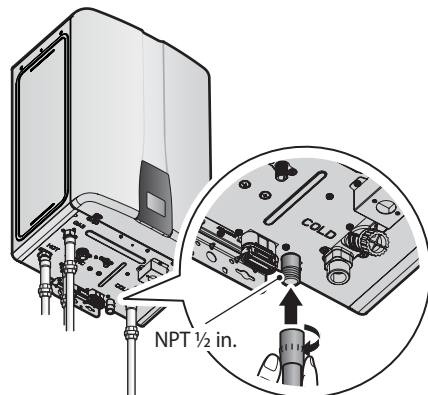

- Place the free end of the drain line into an appropriate drain.

**Note**

- If you are using a condensate pump, ensure that the pump allows for up to 2 GPH of drainage for each water heater in the system.
- If you are not using a condensate pump, ensure that the drain line is pitched downward at a minimum slope of  $\frac{1}{4}$  in. per foot.

- Fill the condensate trap inside the water heater by pouring water through the exhaust vent on top of the water heater until water flows through the condensate drain.

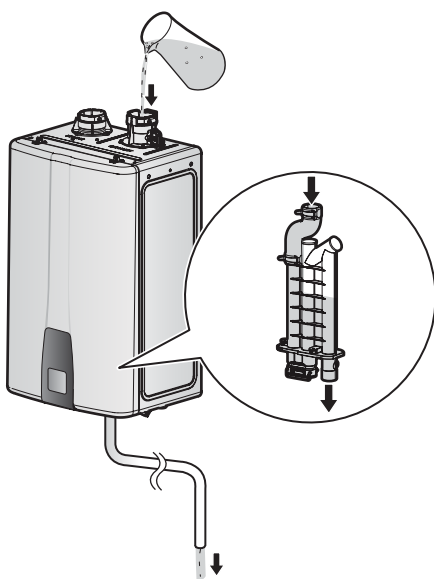

**NOTICE**

To prevent property damage, do not allow condensate line to freeze or become obstructed or condensate can flow from the tee.

### 3.5.1 Condensate Neutralizer Kit

**⚠ WARNING**

To prevent serious injury or death:

- DO NOT allow exhaust flue gases to vent through the neutralizer. Inhalation of flue gases can result in carbon monoxide poisoning.
- ALWAYS install the neutralizer so its inlet and discharge are closer to the floor than the condensate drain.
- ALWAYS install an overflow bypass connection between the appliance and the neutralizer to prevent the backflow of condensate into the appliance.
- DO NOT connect more than one appliance to the neutralizer unless it is rated for use with multiple units.

If option 'b' is selected for condensate disposal, the Navien condensate neutralizer kit is recommended. An increased pH prevents corrosion of the installation's drainage system and the public sewer system.

## Installation

- Set the neutralizer on the floor and place it in position where the outlet is directed toward the external drain.
- Install the neutralizer so that the outlet is positioned toward the external drain.

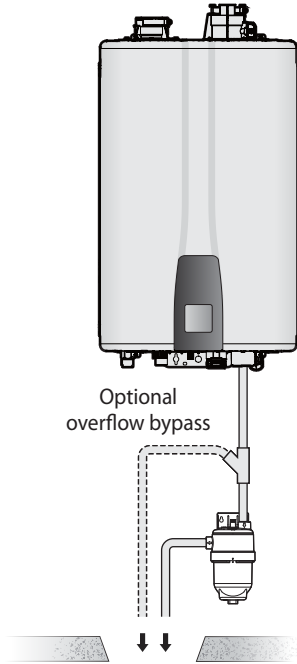

- Ensure that the condensate runs freely to the drain.
- Ensure all connections are made to prevent the backflow of condensate. Use corrosion resistant piping and secure all piping to prevent movement.

### **Note**

Do not install condensate piping in areas where the temperature drops below freezing point. Protect piping in high pedestrian areas from damage and vibration.

- For increased safety when the condensate drain blocks, install a Y-fitting. Connect the Y-fitting as shown in the installation diagram and ensure that the condensate runs freely to the drain.
- Ensure that the discharge connection is accessible. Access to the discharge connection is required for maintenance and pH testing.

## Maintenance

Periodically monitor the level of media in the neutralizer and test the pH level at the outlet. We recommend an annual pH test using recognized test strips or an electronic pH meter to obtain precise measurements. Replace the neutralizing media when the pH drops below the minimum level required by the local water authority. If the pH level is not specified, replace the neutralizing media when the pH is below 6.0. For replacement media, contact your local Navien distributor.

### 3.6 Venting for Combustion Air

#### **WARNING**

##### **Carbon Monoxide Hazard**

The installation of carbon monoxide detectors may be required in your area for your hot water heater or other gas fired appliances. Check applicable codes for the installation location of the water heater.

Carbon monoxide detectors should comply with NFPA 720 and be ANSI/UL 2034 listed and IAS certified.

#### **Additional Guidelines for Combustion Air**

- Combustion air piping to the outside is recommended. (Direct Venting)
- The water heater may be installed with a single pipe carrying the flue products to the outside while using combustion air from the equipment room. In order to use the room air venting option on page 47, specific conditions and considerations must be followed.

#### **WARNING**

To prevent death, serious injury or property damage:

- Do not install the water heater or combustion air piping in areas with contaminated air (e.g. high levels of dust, sawdust, sand, flour, aerosols, fluorine or chlorine compounds).
- **DO NOT** allow liquids or vapors from pool, laundry products, or common household cleaning products to enter hot water heater. These can cause serious product damage and can even result in flue gas leakage in extreme cases.
- **ALWAYS** check for areas and products listed in the following tables before installing the water heater or air inlet piping.
- **ALWAYS** remove contaminants or relocate air inlet and vent terminations to other clean areas. Use direct venting to supply clean air from outside the building. Navien recommends regular filter cleaning and maintenance in these areas.

#### **Note**

The warranty does not cover damage caused by air contaminants.

<b>Corrosive Contaminants</b>
Muriatic acid/hydrochloric acid
Refrigerant leaks
Chlorine-type bleaches, detergents, and cleaning solvents found in household laundry rooms
Varnish removers or paint
Adhesives used to fasten building products and other similar products
Chlorine-based swimming pool chemicals
Permanent wave solutions
Anti-static fabric softeners used in clothes dryers
Calcium chloride used for thawing
Spray cans containing chloro/fluorocarbons
Cements and glues
Sodium chloride used for water softening
Chlorinated waxes/cleaners

<b>Corrosive Sources</b>
Remodeling areas
Refrigeration repair shops
New building construction
Metal fabrication plants
Laundry areas and establishments/dry cleaning
Swimming pools
Auto body shops
Furniture refinishing areas and establishments
Garages with workshops
Plastic manufacturing plants
Beauty shops
Photo processing plants

### 3.6.1 Venting the Water Heater

#### **DANGER**

This appliance is certified as a Category IV appliance and requires a special venting system. The vent system operates with a positive pressure in the pipe.

To prevent serious injury or death:

- ALWAYS vent exhaust gases directly outdoors using the vent materials and following these instructions.
- DO NOT connect vent connectors serving appliances vented by natural draft into any portion of mechanical draft systems operating under positive pressure.

#### **WARNING**

Improper venting of the water heater can result in excessive levels of carbon monoxide and can lead to serious injury or death.

This water heater must be vented in accordance with the "Venting of Equipment" section of the latest edition of the ANSI Z223.1/NFPA 54 Natural Fuel Gas Code in the USA and/or the "Venting systems and air supply for water heaters" section of the latest version of the CAN/CGA B149.1 Natural Gas and Propane Installation Code in Canada, as well as all applicable local building codes and regulations.

To prevent serious injury or death:

- ONLY licensed professionals should install venting.
- ALWAYS follow all regulations, codes, and instructions when venting the water heater.
- ALWAYS seal the venting system gastight to prevent flue gas leakage and carbon monoxide emissions.
- The building owner is responsible to maintain the exhaust and intake terminations free of snow, ice, or other potential blockages, as well as scheduling routine maintenance.

The water heater must be properly vented to ensure a constant supply of clean intake air and to ensure that exhaust air is properly removed from living areas. When venting the water heater, follow these guidelines:

- For best results, keep the venting system as short and straight as possible.
- Locate the water heater as close as possible to the vent termination.
- Do not connect the water heater vent to a vent for any other gas water heater or vent stack.
- For horizontal runs, slope the horizontal section upward toward the vent termination at a rate of ¼ in. per foot (2% slope).
- Create an airtight seal at each joint in the exhaust and intake air pipes from the water heater collar to the vent termination.

#### **Note**

Do not cover any non-metallic vent materials with thermal insulation.

## Connecting the Pipe to the Vent Collar

**Note** Do not use primer or cement on the appliance connection.

### **⚠ WARNING**

ALWAYS properly cut the pipe at a 90° angle and deburr the vent pipe before installing so the pipe is fully connected to the exhaust gas vent fitting.

Use water (NOT grease) to lubricate the end of the vent pipe before inserting into the collar.

ALWAYS insert the vent pipe 2-3/4" (70 mm) into the appliance exhaust collar using a twisting motion until the end reaches the bottom of the socket.

If flue gas leaks, inhalation of carbon monoxide may result in serious injury or death.

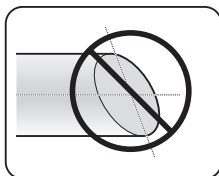
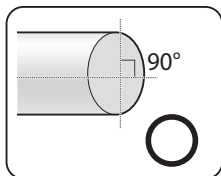
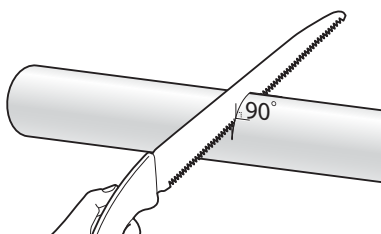

1. Measure 2-3/4" (70 mm) from the end of the vent pipe, then draw a mark at that distance.

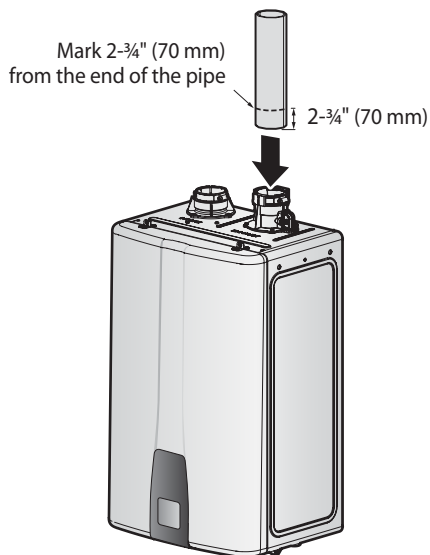

2. Insert the pipe into the vent collar to start the vent run. Make sure to completely slide the vent into the collar until the end makes contact with the bottom of the socket.

**Note** Verify that 2-3/4" (70 mm) of the pipe has been completely inserted into the collar and that the mark is no longer visible.

3. Tighten the clamp with a socket wrench (8 mm) to properly seal the joint.

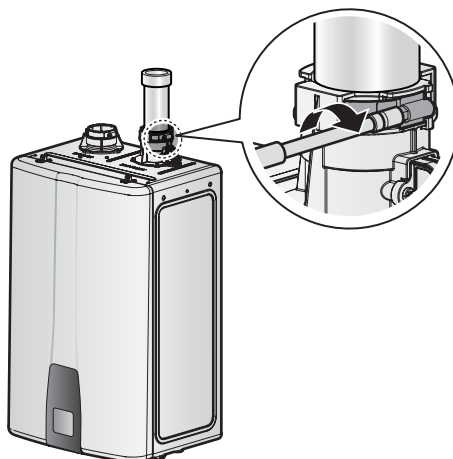

## **⚠ WARNING**

NEVER start the vent run with a **street elbow** at the vent collar to prevent serious injury or death. Using an elbow directly at the collar will not allow for a tight seal between the appliance and the vent pipe.

ALWAYS use a length of straight pipe when starting the vent run.



- To avoid moisture and frost build-up and to maintain clearances to openings on adjacent homes, 45° elbows, 90° elbows, or tees may be attached to the end of the termination vent pipe to direct the exhaust plumes away from buildings, as long as the total allowable vent lengths, maximum number of elbows, and distances to air intake restrictions are observed.
- Do not store hazardous or flammable substances near the vent termination.
- If this water heater will be installed in areas where snow is known to accumulate, protect the vent termination from blockage. Ensure that the vent termination is at least 12 in. (305 mm) above the highest anticipated snow line, or as required by local codes, whichever is greater.
- Support the vent pipe with hangers at regular intervals or as required by local codes. Exhaust and intake air pipes must be supported at least every 4 ft (1.2 m).
- The vent for this appliance shall not terminate over public walkways; or near soffit vents or crawl space vents or where condensate or vapor could create a nuisance or hazard or cause property damage; or where condensate or vapor could cause damage or could be detrimental to the operation of regulators, relief valves, or other equipment.

## **⚠ WARNING**

ALWAYS turn on the water heater and test for gas leaks along the exhaust vent using a bubble test kit.

If the connections leak, carbon monoxide in the flue gas may cause serious injury or death.

### **3.6.2 About the Vent Installation Detector**

This water heater unit comes pre-installed with a Vent Installation Detector (“VID”) to assist the installer in properly installing the Vent Pipe into the vent collar.

#### **How It Works**

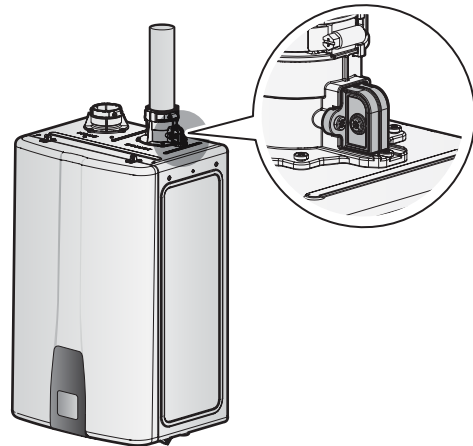

As shown, the VID is a device connected to the vent collar which is intended to detect whether the vent pipe has been inserted to a sufficient depth (at least 2-3/4" (70 mm)) into the collar during its initial installation. If a correctly sized vent pipe (2.0 inches) is fully inserted into the collar, it will press against a switch to activate the VID. If the vent pipe is not fully inserted into the collar, the unit will display an error message and will not operate. Make sure the vent pipe is correctly sized and has been inserted properly if Error 762 appears.

## Purpose

The VID's purpose is to guide the installer to fully insert the vent pipe to a depth of at least 2-3/4" (70 mm), into the collar. If the vent pipe is not properly inserted and installed, it could separate from the collar resulting in flue gas spillage and carbon monoxide emissions which will result in severe personal injury or death.

### **WARNING**

Periodically inspect all vent pipe connections.

The Vent Installation Detector (VID) will NOT detect the separation of connected vent pipe if the joints become detached or are leaking flue gas that may contain carbon monoxide.

The VID is not intended and should not be relied upon to detect all instances of vent pipe movement or separation from the collar.

Various factors, including but not limited to sensor failure, switch sticking and corrosion, may cause the VID to not properly function if the vent pipe separates from the collar.

### **WARNING**

#### **Carbon Monoxide Hazard**

To prevent serious injury or death:

- ALWAYS insert vent pipe 2-3/4" (70 mm) into the water heater exhaust collar.
- If the vent pipe is not fully inserted, the vent installation detector switch may not detect its presence and the water heater may not operate.
- ALWAYS only use the correctly sized vent pipe materials or an error code E762 can appear on the front panel if the vent pipe is not properly installed.
- The factors that can effect the performance of the VID include, but are not limited to, deformity of the vent pipe, not using a correctly sized vent pipe, misalignment of the vent pipe into the collar, vertical movement of the vent pipe caused by improper installation, and other misuse or non-conformance with installation instructions.

## Limitations

The VID is not an alarm, safety switch or a substitute for a carbon monoxide detector. The VID may not cause the unit to stop operating if the vent pipe is partially or completely dislodged. Other factors can impact the performance of the VID causing it to be unable to function as intended. Such factors include, but are not limited to, deformity of the vent pipe, not using a correctly sized vent pipe, misalignment of the vent pipe into the collar, vertical movement of the vent pipe caused by improper installation, and other misuse or non-conformance with installation instructions.

## **⚠ WARNING**

### **Carbon Monoxide Hazard**

To prevent serious injury or death:

- ALWAYS visually inspect the vent pipe before inserting the vent pipe into the water heater exhaust collar. The vent pipe inserted into the water heater exhaust collar must be free from damage or defects for the vent installation detector to operate properly. If the vent pipe is damaged, then replace it with new vent pipe.
- The vent installation detector only detects separation of the vent pipe from the water heater exhaust collar if fully inserted 2- $\frac{3}{4}$ " (70 mm). The vent installation detector will not detect the separation of connected vent pipe if the joints become detached or are leaking flue gas that may contain carbon monoxide.
- It is the installer's responsibility to install the vent pipe properly, to check for leaks, and to adequately secure the water heater to the wall.

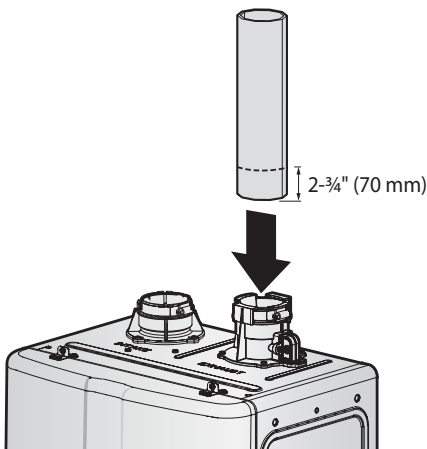

## **⚠ WARNING**

Periodically inspect all vent pipe connections. The VID is not intended and should not be relied upon to detect all instances of vent pipe movement or separation from the collar.

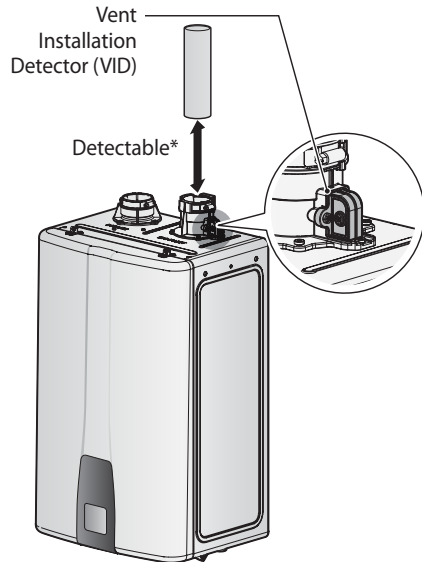

\*If inserted 2- $\frac{3}{4}$ " (70 mm), then VID should detect vent pipe.

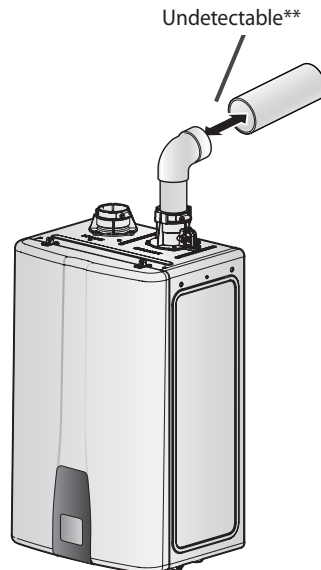

\*\*VID can not detect if the vent pipe is leaking or disconnected at any point between the water heater and the exterior vent location or if the vent is blocked for any reason.

### 3.6.3 Selecting a Vent Type

Navien NPE Series water heaters are Category IV appliances and are prepared at the factory to be direct vent (sealed combustion) appliances that draw all of their required combustion air directly from the outdoors. Navien recommends direct air vent installations whenever possible to avoid back drafting cold air through the water heater. If you cannot use a direct vent, ensure that an ample supply of make-up air is available in the installation location.

Navien also recommends installing a new vent system with this appliance. If reusing an existing vent system, thoroughly inspect it for punctures, cracks, or blockages prior to connecting it to the water heater.

### Direct Venting

The water heater uses 2 in. to 4 in. diameter exhaust and diameter intake air ducts. To ensure the draw of air directly from and exhaust of air directly to the outside of the building, create an airtight seal from the water heater collar to the vent termination.

Intake materials can be made of ABS, PVC, CPVC, PP, galvanized steel, corrugated aluminum or any other such materials. If you use a corrugated material, ensure that there is not inadvertent crimping of, or damage to, the intake air pipe.

When using direct venting, maintain the following venting clearances, as required by **CSA/ANSI Z21.10.3 and the National Fuel Gas Code, ANSI Z223.1/NFPA 54, and CAN/CGA B149.1 Natural Gas and Propane Installation Code:**

### Terminal Clearances for Direct Vent Installations

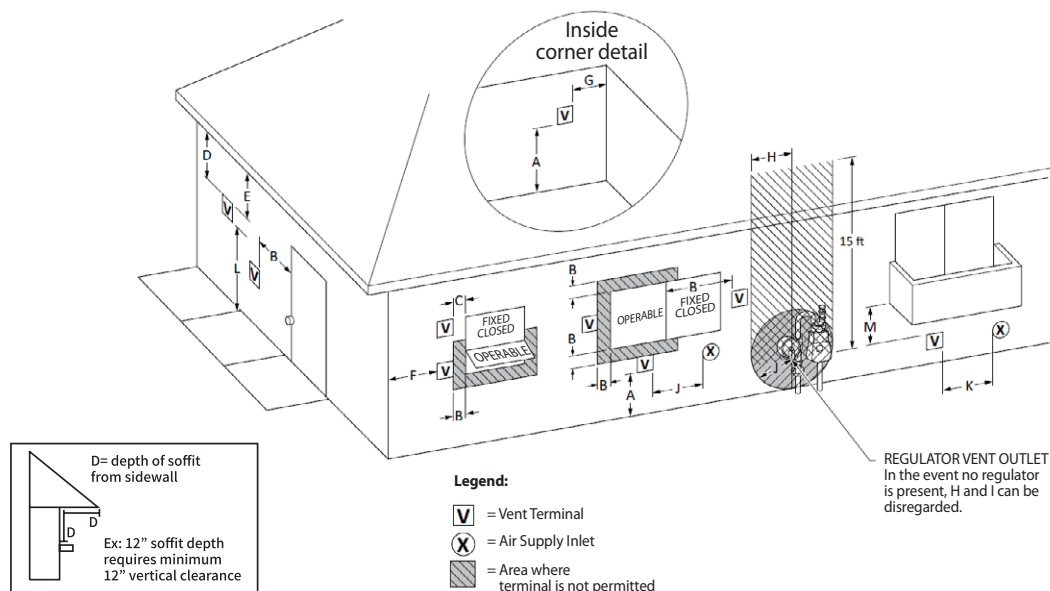

Ref	Description	Canadian installations <sup>1</sup>	US installations <sup>2</sup>
A	Clearance above grade, veranda, porch, deck, or balcony	12 in. (30 cm)	12 in. (30 cm)
B	Clearance to window or door that may be opened	36 in. (91 cm) for appliances >100,000 Btuh (30 kW)	12 in. (30 cm) for appliances >50,000 Btuh (15 kW)

Ref	Description	Canadian installations <sup>1</sup>	US installations <sup>2</sup>
C	Clearance to permanently closed window	0 in (0 cm) <sup>5</sup>	0 in (0 cm) <sup>5</sup>
D	Vertical clearance to ventilated soffit located above the terminal within a horizontal distance of 2 ft (61 cm) from the center line of the terminal.	Equal or greater than soffit depth <sup>4,5</sup>	Equal or greater than soffit depth <sup>4,5</sup>
E	Clearance to unventilated soffit	Equal or greater than soffit depth <sup>4,5</sup>	Equal or greater than soffit depth <sup>4,5</sup>
F	Clearance to outside corner	2 ft (61 cm)*	2 ft (61 cm)*
G	Clearance to inside corner	12 in. (30 cm)*	12 in. (30 cm)*
H	Clearance to each side of center line extended above meter/regulator assembly	3 ft (91 cm) within a height of 15 ft (4.6 m)	3 ft (91 cm) within a height of 15 ft (4.6 m)*
I	Clearance to service regulator vent outlet	3 ft (91 cm)	3 ft (91 cm)*
J	Clearance to nonmechanical air supply inlet to building or the combustion air inlet to any other appliance	36 in. (91 cm) for appliances >100,000 Btuh (30 kW)	12 in. (30 cm) for appliances > 50,000 Btuh (15 kW)
K	Clearance to a mechanical air supply inlet	6 ft (1.83 m)	3 ft (91 cm) above if within 10 ft (3 m) horizontally
L	Clearance above paved sidewalk or paved driveway located on public property	7 ft (2.13 m) <sup>†</sup>	7 ft (2.13 m) for mechanical draft systems (Category I appliances). Vents for Category II and IV appliances cannot be located above public walkways or other areas where condensate or vapor can cause a nuisance or hazard*
M	Clearance under veranda, porch deck, or balcony	12 in. (30 cm) <sup>‡</sup>	12 in. (30 cm) - open on 3 sides*

\* Suggested clearances by the manufacturer. If the clearances required by local codes are different from those from the table above, the greater clearance should apply. Direct exhaust vapors and condensate away from building materials to avoid degradation. The minimum distance from adjacent public walkways, adjacent buildings, openable windows, and building openings shall not be less than those values specified in the National Fuel Gas Code, ANSI Z223.1/NFPA 54, and/or the Natural Gas and Propane Installation Code, CSA B149.1.

† A vent shall not terminate directly above a sidewalk or paved driveway that is located between two single family dwellings and serves both dwellings.

‡ Permitted only if veranda, porch, deck, or balcony is fully open on a minimum of two sides beneath the floor.

#### Note

<sup>1</sup> In accordance with the current CSA B149.1 Natural Gas and Propane Installation Code

<sup>2</sup> In accordance with the current ANSI Z223.1/NFPA 54 National Fuel Gas Code

<sup>3</sup> If locally adopted installation codes specify clearances different than those illustrated, then the most stringent clearance shall prevail.

<sup>4</sup> Soffit with 12" depth requires a minimum of 12" vertical clearance from the termination (36" soffit requires a minimum of 36" vertical clearance)

<sup>5</sup> In the areas where corrosion and discoloration of building materials can occur, a minimum clearance of 12" shall apply.

## Non-Direct Venting (Single Pipe)

If, at any time, the installation location could experience negative pressure, there is a possibility of back drafting cold air through the water heater's heat exchanger. This situation could lead to the freezing of the heat exchanger and malfunction of the water heater.

However, building codes in most jurisdictions disallow negative pressures in residences. In a home with a well-balanced air supply, the heat exchanger should not be in danger of freezing. Because the cause of back drafting is not considered a manufacturing problem, any freezing damage which occurs from back drafting will not be covered by the Navien warranty. If there is any question about the possibility of back drafting in the installation location, use a direct venting system for the water heater.

When installed in a manufactured home, all combustion air must be supplied from the outdoors as described on page 40.

### **⚠ WARNING**

#### **Carbon Monoxide Hazard**

NEVER install this water heater in a recreational vehicle, trailer, boat or other moving vehicle to prevent serious injury or death.

When using non-direct venting, maintain non-direct vent clearances shown on page 50 as required by **CSA/ANSI Z21.10.3 and the National Fuel Gas Code, ANSI Z223.1/NFPA 54, and CAN/CSA B149.1 Natural Gas And Propane Installation Code.**

To use non-direct venting for the water heater:

1. Insert the termination end cap into the intake air duct.

#### **Note**

Do NOT glue the end cap to allow for easy removal and cleaning of the cap.

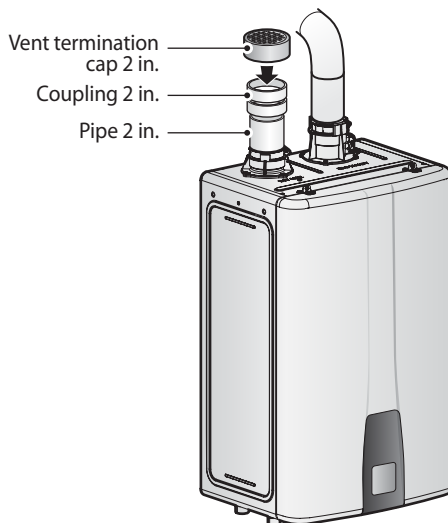

2. The equipment room MUST be provided with properly sized openings to assure adequate combustion air.
3. Combustion air requirements are based on the latest edition of the National Fuel Gas Code, NFPA 54 / ANSI Z223.1; in Canada refer to the latest edition of CGA Standard CAN/CSA B149.1. All local codes supersede these clearance requirements when applicable.

	Maximum Input (BTU/H)	Outdoor make up air is provided, a minimum free area of 1 in <sup>2</sup> . per 4,000 BTU/H	Indoor make up air is provided, a minimum free area of 1 in <sup>2</sup> . per 1,000 BTU/H
NPE-150S2	120,000	30 in <sup>2</sup> . 10 in. (W) x 3 in. (H) or 6 in. round	120 in <sup>2</sup> . 11 in. (W) x 11 in. (H)
NPE-180A2 NPE-180S2	150,000	40 in <sup>2</sup> . 10 in. (W) x 4 in. (H) or 7 in. round	150 in <sup>2</sup> . 12 ¼ in. (W) x 12 ¼ in. (H)
NPE-210A2 NPE-210S2	180,000	45 in <sup>2</sup> . 10 in. (W) x 5 in. (H) or 8 in. round	180 in <sup>2</sup> . 13 ¼ in. (W) x 13 ¼ in. (H)
NPE-240A2 NPE-240S2	199,900	50 in <sup>2</sup> . 10 in. (W) x 5 in. (H) or 8 in. round	199 in <sup>2</sup> . 14 ¼ in. (W) x 14 ¼ in. (H)

## Terminal Clearances for Non-Direct Vent Installations

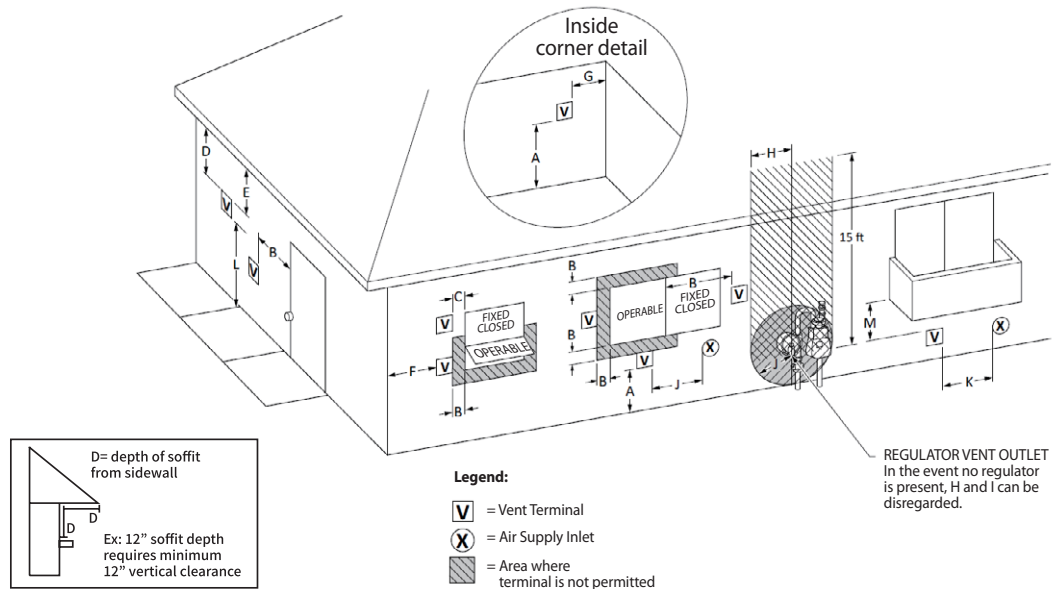

Ref	Description	Canadian installations <sup>1</sup>	US installations <sup>2</sup>
A	Clearance above grade, veranda, porch, deck, or balcony	12 in. (30 cm)	12 in. (30 cm)
B	Clearance to window or door that may be opened	36 in. (91 cm) for appliances > 100,000 Btuh (30 kW)	4 ft (1.21 m) below or to side of opening; 1 ft (300 mm) above opening
C	Clearance to permanently closed window	0 in (0 cm) <sup>5</sup>	0 in (0 cm) <sup>5</sup>
D	Vertical clearance to ventilated soffit located above the terminal within a horizontal distance of 2 ft (61 cm) from the center line of the terminal	Equal or greater than soffit depth <sup>4,5</sup>	Equal or greater than soffit depth <sup>4,5</sup>
E	Clearance to unventilated soffit	Equal or greater than soffit depth <sup>4,5</sup>	Equal or greater than soffit depth <sup>4,5</sup>
F	Clearance to outside corner	2 ft (61 cm)*	2 ft (61 cm)*
G	Clearance to inside corner	12 in. (30 cm)*	12 in. (30 cm)*
H	Clearance to each side of center line extended above meter/regulator assembly	3 ft (91 cm) within a height of 15 ft (4.6 m)	3 ft (91 cm) within a height of 15 ft (4.6 m)*
I	Clearance to service regulator vent outlet	3 ft (91 cm)	3 ft (91 cm)*

Ref	Description	Canadian installations <sup>1</sup>	US installations <sup>2</sup>
J	Clearance to nonmechanical air supply inlet to building or the combustion air inlet to any other appliance	36 in. (91 cm) for appliances >100,000 Btuh (30 kW)	4 ft (1.2 m) below or to side of opening; 1 ft (300 mm) above opening
K	Clearance to a mechanical air supply inlet	6 ft (1.83 m)	3 ft (91 cm) above if within 10 ft (3 m) horizontally
L	Clearance above paved sidewalk or paved driveway located on public property	7 ft (2.13 m) <sup>†</sup>	7 ft (2.13 m) for mechanical draft systems (Category I appliances). Vents for Category II and IV appliances cannot be located above public walkways or other areas where condensate or vapor can cause a nuisance or hazard
M	Clearance under veranda, porch deck, or balcony	12 in. (30 cm) <sup>‡</sup>	12 in. (30 cm) - open on 3 sides*

\* Suggested clearances by the manufacturer. If the clearances required by local codes are different from those from the table above, the greater clearance should apply. Direct exhaust vapors and condensate away from building materials to avoid degradation. The minimum distance from adjacent public walkways, adjacent buildings, openable windows, and building openings shall not be less than those values specified in the National Fuel Gas Code, ANSI Z223.1/NFPA 54, and/or the Natural Gas and Propane Installation Code, CSA B149.1.

† A vent shall not terminate directly above a sidewalk or paved driveway that is located between two single family dwellings and serves both dwellings.

‡ Permitted only if veranda, porch, deck, or balcony is fully open on a minimum of two sides beneath the floor.

**Note**

<sup>1</sup> In accordance with the current CSA B149.1 Natural Gas and Propane Installation Code

<sup>2</sup> In accordance with the current ANSI Z223.1/NFPA 54 National Fuel Gas Code

<sup>3</sup> If locally adopted installation codes specify clearances different than those illustrated, then the most stringent clearance shall prevail.

<sup>4</sup> Soffit with 12" depth requires a minimum of 12" vertical clearance from the termination (36" soffit requires a minimum of 36" vertical clearance)

<sup>5</sup> In the areas where corrosion and discoloration of building materials can occur, a minimum clearance of 12" shall apply.

### 3.6.4 Selecting Vent Pipe Materials

Venting requirements differ in the US and Canada. Consult the following chart or the most recent edition of ANSI Z223.1/NFPA 54 or CAN/CGA B149.1, as well as all applicable local codes and regulations when selecting vent pipe materials. Do not use cellular core PVC (ASTM F891), cellular core CPVC, Radel® (polyphenylsulfone) for the exhaust vent.

⚠
WARNING

**Carbon Monoxide Hazard**

To prevent serious injury or death:

- ONLY use approved venting materials.
- Review the vent pipe installation instructions carefully. Improper use and installation of vent pipe may cause system to fail and harmful flue products may leak into the living space.

The use of unapproved vent materials will also void the warranty and certification of the water heater.

Locale	Recommended Vent Materials
USA	<ul style="list-style-type: none"> <li>• PVC/CPVC Schedule 40 or 80 (Solid Core)</li> <li>• UL1738 approved PVC or CPVC</li> <li>• Approved Polypropylene (PP)</li> <li>• Approved Stainless Steel (SS)</li> </ul>
Canada*	<ul style="list-style-type: none"> <li>• Type BH Special Gas Vent Class IIA (PVC)</li> <li>• Type BH Special Gas Vent Class IIB (CPVC)</li> <li>• Type BH Special Gas Vent Class IIC (Polypropylene/Stainless Steel)</li> </ul>

\* For installation in Canada, field-supplied plastic vent piping must comply with CAN/CGA B149.1 (latest edition) and be certified to the Standard For Type BH Gas Venting Systems, ULC-5636. Components of this listed system must not be interchanged with other vent systems or unlisted pipes or fittings. The supplied vent connector and vent termination are certified as part of the water heater.

The vent system shall be installed in accordance with the water heater manufacturer and, if applicable, the venting system manufacturer's instructions.

This product is set to use **PVC** as the default vent pipe material. If the return water temperature for the application is higher than 140°F (60°C) to circulate back to water heater, **Exhaust Limit Control** (parameter settings) must be set to **OFF**. Otherwise, the water heater will control maintain the exhaust and DHW temperatures below 150°F (65°C) and 140°F (60°C) respectively.

To change the **Exhaust Limit Control** parameter setting, press and hold the Menu button (M) and the Back button (←) simultaneously for 3 seconds to access the Service/Installer menu. Then select **1. Installer Menu > 2. Parameter Settings > 6. Exhaust Limit Control** by pressing the OK button (OK).

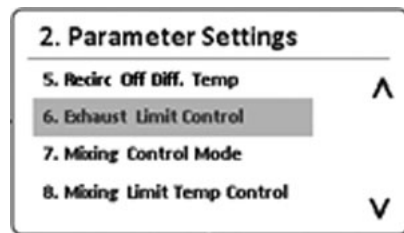
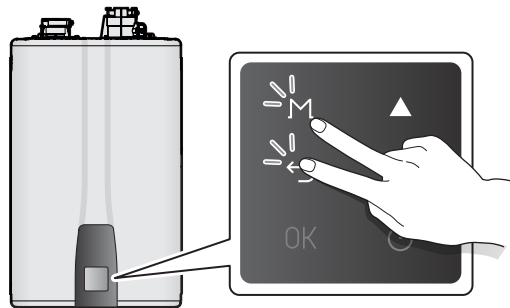

**Note**

- When **Exhaust Limit Control** (parameter settings) is set to **Disable** (the factory default is Enable), CPVC, PP, or SS vent must be used for the exhaust pipe.
- For more information about the Parameter settings, refer to “6.8 Maintenance” on page 88.

## **WARNING**

### **Carbon Monoxide Hazard**

To prevent serious injury or death:

- This water heater has a built-in control to limit the exhaust temperature to 149°F. As a result, the Navien water heater can be vented with Schedule 40 PVC.
- In high temperature applications, the exhaust temperature can exceed 149°F (65°C). In that case, you must use Schedule 40/80 CPVC or Approved Polypropylene/Stainless Steel in the USA or Type BH Special Gas Vent Class IIB (CPVC) or Class IIC (Polypropylene/SS) that conforms to ULC-S636 in. Canada.
- When using 2 in. vent, if the exhaust temperature exceeds 149°F (65°C), CPVC pipe (field supplied) must be used for the first 3 feet of equivalent pipe length. For systems using 3 in. vent, the first 5 in. of length must be CPVC pipe.

### **Note**

- Only the vent pipe models listed above are approved for use with this appliance.
- Refer to the vent manufacturer's instructions for detailed installation procedures and guidelines.

The following **polypropylene** vent components are approved for use with this appliance:

- **DuraVent PolyPro® SW (Rigid)** (Certified to ULCS636)  
2PPS-xxx (2") or 3PPS-xxx (3")
- **DuraVent PolyPro® (Flexible)** (Certified to ULCS636)  
3PPS-FLEXxx (3")  
2PPS-FAM or 3PPS-FAM (2" or 3" Rigid-to-Flex Male Adapter)  
2PPS-X3L (2" to 3" Increaser)
- **Centrotherm Innoflue® SW (Rigid)** (Certified to UL1738 and ULCS636)  
ISxx02xx (2") or ISxx03xx (3")
- **Centrotherm Innoflue® (Flexible)** (Certified to UL1738 and ULCS636)  
IFVL02xxx (2") or IFVL03xx (3")  
IFSFC02 or IFSFC03 (2" or 3" Rigid-to-Flex Male Adapter)  
ISEI0203 or ISIA0203 (2" to 3" Increaser)
- **Hart & Cooley Polyflue™ SW (Rigid)** (Certified to ULCS636)  
2PF-xx (2") or 3PF-xx (3")
- **Z-Flex® Z-DENS SW (Rigid)** (Certified to UL1738 and ULCS636)  
2ZDxx (2") or 3ZDxx (3")
- **ECCO Polypropylene Vent (Rigid)** (Certified to ULCS 636)  
2xxPPP (2") or 3xxPPP (3")  
245PEL/287PEL (2" 45°/90° Elbow)  
345PEL/387PEL (3" 45°/90° Elbow)  
203PINC (2" x 3" Increaser)

The following **stainless steel** vent components are approved for use with this appliance:

- **DuraVent FasNSeal® (Rigid)** (Certified to UL1738 and ULCS636)  
FSA-PVC3 (3" PVC to FasNSeal Appliance Adapter)  
FSxxxxx03 (3")
- **DuraVent FasNSeal® (Flexible)** (Certified to UL1738 and ULCS636)  
FSASMM-PP-2 (2" PP-to-FasNSeal adapter)  
FSFLEX-02 (2")
- **Heat Fab Saf-T Vent® EZ Seal** (Certified to UL1738 and ULCS636)  
9301PVC (3" PVC/CPVC Outlet Boiler Adapter)  
93xx (3")
- **Z-Flex® Z Vent** (Certified to UL1738 and ULCS636)  
2SVSTTA023 (2" x 3" Appliance Adapter)  
2SVEPSCF030X (Straight Pipe)  
2SVEEWCF0390 (90° Elbow)  
2SVEEWCF0345 (45° Elbow)

### 3.6.5 Measuring Vent Length

The maximum vent length when using 2 in. exhaust ducts is 75 ft (23 m). The maximum vent length when using 3 in. vent ducts is 150 ft (45 m). The intake and exhaust vent pipes can be of different lengths as the water heater will adjust for pressure imbalances within the system. Maximum vent length is reduced according to the number of elbows used, as shown in the following table:

Vent Size	Max. Length	Max. # of 90° Elbows	Equivalent Lengths
2 in.	75 ft (23 m)	6	Reduce the maximum vent length accordingly for each elbow used: <ul style="list-style-type: none"> <li>• Each 90° elbow equates to 8 linear ft (2.4 m) of vent</li> <li>• Each 45° elbow equates to 4 linear ft (1.2 m) of vent</li> </ul>
3 in.	150 ft (45 m)	8	Reduce the maximum vent length accordingly for each elbow used: <ul style="list-style-type: none"> <li>• Each 90° elbow equates to 5 linear ft (1.5 m) of vent</li> <li>• Each 45° elbow equates to 3 linear ft (0.9 m) of vent</li> </ul>
4 in.	150 ft (45 m)	8	Reduce the maximum vent length accordingly for each elbow used: <ul style="list-style-type: none"> <li>• Each 90° elbow equates to 5 linear ft (1.5 m) of vent</li> <li>• Each 45° elbow equates to 3 linear ft (0.9 m) of vent</li> </ul>

#### Note

- The Maximum Length does not include any elbows.
- The use of a PVC or polypropylene concentric termination counts as 5 linear feet (1.5 m) of vent.
- The maximum vent lengths at high altitudes are the same as shown in the above.
- Only tee and elbow terminations can be used with a 4" vent.

### 3.6.6 Terminating the Vent

Before installing the water heater, determine what type of vent termination is appropriate for the installation location and materials. The subsections that follow describe some typical venting configurations, but do not include all possible options.

The following **PVC** vent terminations are approved for use with this appliance:

- **IPEX** (Certified to ULCS636)
  - 2 in. FGV Concentric Kit #196105
  - 3 in. FGV Concentric Kit #196106
- **IPEX** (Certified to UL1738)
  - 2 in. FGV Concentric Kit #397105
  - 3 in. FGV Concentric Kit #397106
- **Diversitech** (Certified to ULCS636)
  - 2 in. Kit #CVENT-2
  - 3 in. Kit #CVENT-3
  - 2 in. Low Profile PVC #HVENT2
  - 3 in. Low Profile PVC #HVENT3
- **IPEX** Low Profile Termination Kit (Certified to ULCS636)
  - 2 in. Low Profile Vent Kit #196984
  - 3 in. Low Profile Vent Kit #196985
- **IPEX** Low Profile Termination Kit (Certified to UL1738)
  - 2 in. Low Profile Vent Kit #397984
  - 3 in. Low Profile Vent Kit #397985
- **IPEX** Universal Concentric Vent Kit (Certified to ULCS636)
  - 2 or 3 in. PVC #196256
  - 2 or 3 in. CPVC #197256 (Certified to UL1738)
  - 2 or 3 in. PVC #397256
- **Royal Pipe** Low Profile Concentric Vent Kit (Certified to ULCS636)
  - 2 in. PVC #52CVKGV6502
  - 3 in. PVC #52CVKGV6503
  - 3 in. CPVC #52CVKGVSF9003

The following **polypropylene** vent terminations are approved for use:

- **Duravent PolyPro®** Horizontal Concentric Termination Kit (Certified to ULCS636)
  - 2 in. x 4 in. Concentric Vent Kit #2PPS-HKC
  - 3 in. x 5 in. Concentric Vent Kit #3PPS-HKC

- **Centrotherm Innoflue**® Low Profile Termination Kit (Certified to UL1738 and ULCS636)  
2 in. Vent Kit #ISLPT0202  
3 in. Vent Kit #ISLPT0303
- **Centrotherm** Concentric Vent Kit (Certified to UL1738 and ULCS636)  
2 in. Vent Kit #ICWT242  
3 in. Vent Kit #ICWT352
- **Hart & Cooley Polyflue**™ Horizontal Termination Kit (Certified to ULCS636)  
2 in. Vent Kit #2PF-HCT  
3 in. Vent Kit #3PF-HCT
- **Z-Flex**® **Z DENS** Horizontal Termination (Certified to UL1738 and ULCS636)  
2 in. Vent Kit #2ZDHK2  
3 in. Vent Kit #2ZDHK3
- **ECCO** Polypropylene Vent (Rigid) (Certified to ULCS636)  
2 in. Vent Kit #24022AD  
3 in. Vent Kit #35033AD

The following **polypropylene** vent components can be used as terminations:

- **Duravent PolyPro**® (Certified to ULCS636)  
2PPS-E90L or 3PPS-E90L (2" or 3" 90° Elbow)  
2PPS-E45L or 3PPS-E45L (2" or 3" 45° Elbow)  
2PPS-TL or 3PPS-TL (2" or 3" Tee)  
2PPS-BG or 3PPS-BG (2" or 3" Birdscreen)
- **Centrotherm Innoflue**® (Certified to UL1738 and ULCS636)  
ISELL0287 or ISELL0387 (2" or 3" 87° Elbow)  
ISELL0245 or ISELL0345 (2" or 3" 45° Elbow)  
IST02 or IST03 (2" or 3" Tee)  
IASPP02 or IASPP03 (2" or 3" Birdscreen)
- **Hart & Cooley Polyflue**™ (Certified to ULCS636)  
2PF-90 or 3PF-90 (2" or 3" 90° Elbow)  
2PF-45 or 3PF-45 (2" or 3" 45° Elbow)  
2PF-T or 3PF-T (2" or 3" Tee)  
2PF-HVST or 3PF-HVST (2" or 3" Birdscreen)
- **Z-Flex**® **Z-DENS** (Certified to UL1738 and ULCS636)  
2ZDE\_87 or 3ZDE\_87 (2" or 3" 87° Elbow)  
2ZDE\_45 or 3ZDE\_45 (2" or 3" 45° Elbow)  
2ZDTT or 3ZDTT (2" or 3" Tee)  
2ZDES or 3ZDES (2" or 3" Birdscreen)

The following **stainless steel** (AL29-4C) vent components can be used as terminations:

- **Duravent FasNSeal**® (Certified to UL1738 and ULCS636)  
FSELB9003 (3" 90° Elbow)  
FSELB8803 (3" 88° Elbow)  
FSELB4503 (3" 45° Elbow)  
FST3 (3" Tee)  
FSBS3 (3" Birdscreen)
- **Heat Fab Saf-T Vent**® **EZ Seal** (Certified to UL1738 and ULCS636)  
9314(LR) or 9314TERM (3" 90° Elbow)  
9311 (3" 45° Elbow)  
9390TEE (3" Tee)  
9392 (3" Birdscreen)
- **Z-Flex**® **Z Vent** (Certified to UL1738 and ULCS636)  
2SVEEWCF0390 (90° Elbow)  
2SVEEWCF0345 (45° Elbow)  
2SVSTTF03 (3" Tee)

#### Note

- Only the termination models listed above are approved for use with this appliance.
- Refer to the vent manufacturer's instructions for detailed installation procedures and guidelines.

## Indoor Water Heater Installation

### Venting Examples

#### **WARNING**

##### **Fire and Explosion Hazard**

To prevent death, serious injury or property damage:

- ALWAYS make sure to follow the provided clearance requirements.
- Failure to do so may result in circulating exhaust gas and cause dangerous operation of the water heater.

The following are some possible indoor venting options:

- Two-Pipe Sidewall Venting

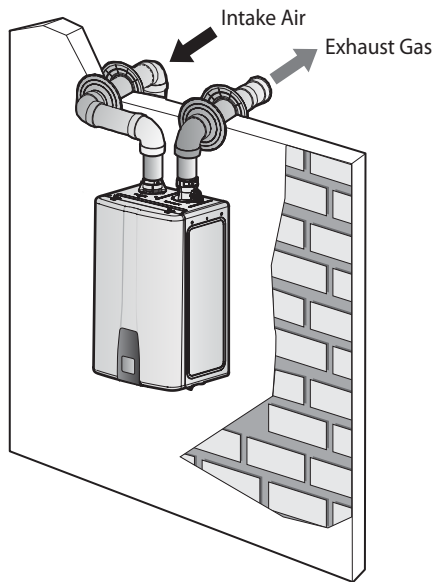

[Interior View]

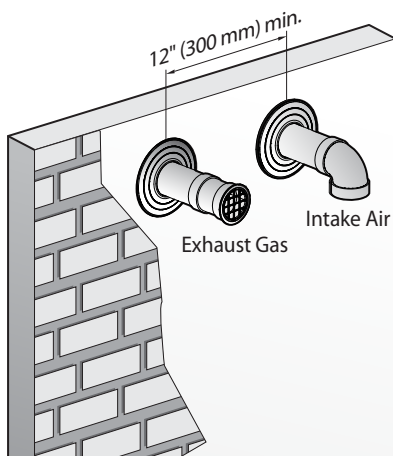

[Exterior View]

- Two-pipe Vertical Venting - Intake and exhaust pipes do not have to terminate in the same area.

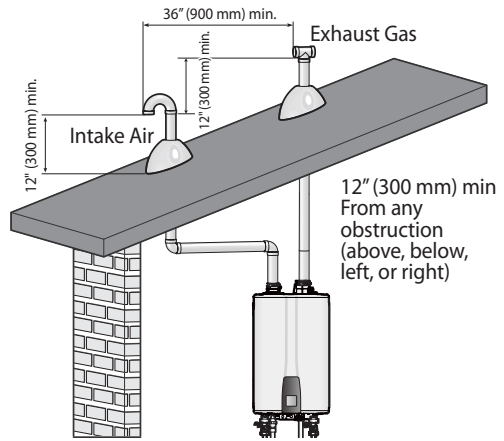

- Non-Concentric Sidewall Venting: Air is drawn from a different location that is at least 12 in. (300 mm) away from the exhaust termination. The exhaust termination can be located either on the sidewall or roof. Try to minimize the length of the intake air pipe when installing the vent.

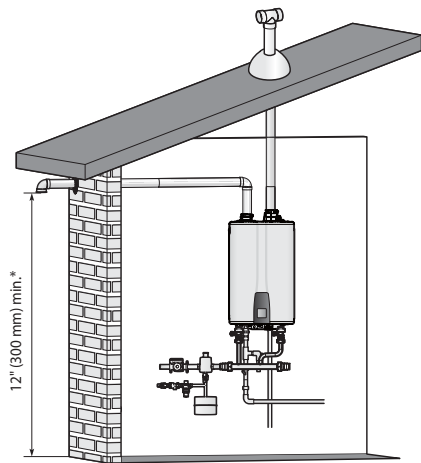

\*12" (300 mm) above the highest anticipated snow level, or as required by local codes, whichever is greater.

- Concentric Sidewall Venting

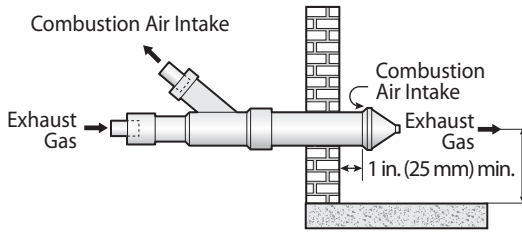

Maintain 12" (300mm) min. clearance above highest anticipated snow level or grade, whichever is greater.

- Concentric Vertical Venting

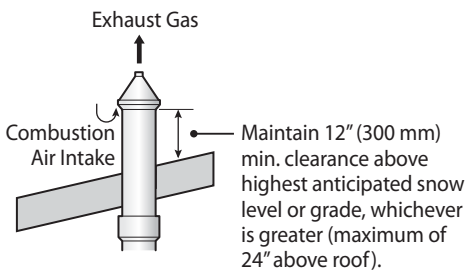

**Note** For cascade applications, the required horizontal clearance between terminations is 12" for both sidewall and vertical venting installations.

### CAUTION



Do not vertically stack concentric terminations on sidewalls. The circulation of exhaust gases will cause improper operation of the water heater.

- Multiple Low-Profile Terminations on Sidewall (Cascade Only)

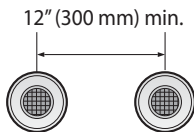

- Multiple Low-Profile Terminations on Roof (Cascade Only)

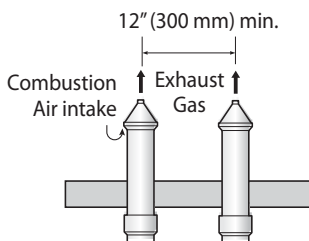

- Low Profile Two-Pipe Sidewall Venting\*

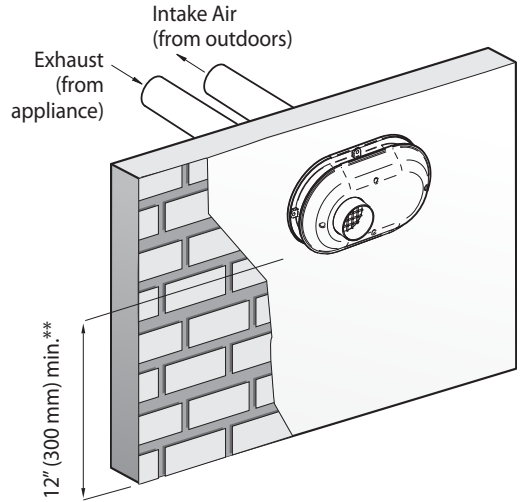

[Exterior View]

\* IPEX and Centrotherm Low Profile terminations only - Check the list of approved low profile sidewall terminations in the previous pages.

\*\* Clearance above highest anticipated snow level or grade, or as required by local codes, whichever is greater.

**Note**

Only the following orientations are allowed for twin pipe terminations.



NEVER install in this orientation with the exhaust located nearest to the ground.

- Multiple Low-Profile Terminations for Cascade Applications

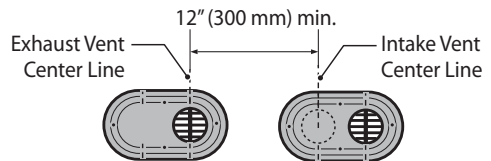

- Two-Pipe Snorkel Sidewall Venting

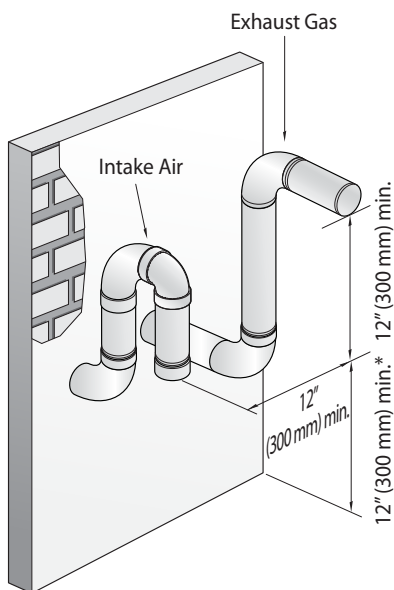

\* Clearance above highest anticipated snow level or grade, or as required by local codes, whichever is greater.

- Flexible Vent Systems (Polypropylene and Stainless Steel)

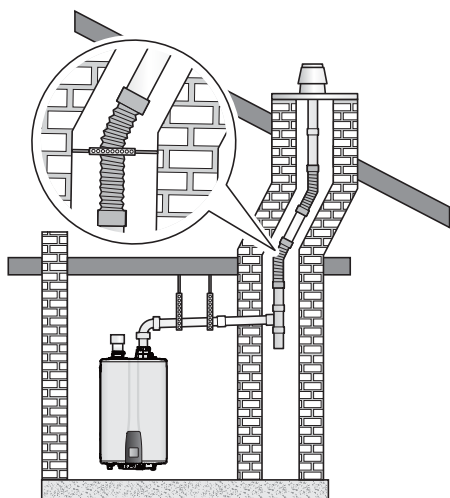

**Note**

- Only VERTICAL installations are allowed. Horizontal terminations are prohibited.
- The use of proper adapters and supports are required to fully complete the installation.

The following table lists the flexible vent models that are approved for use with this appliance in addition to the maximum allowable vent lengths for the desired vent system.

Model Type	Vent Dia.	Flexible PP		Flexible SS
		Centrotherm InnoFlue Flex*	DuraVent Polypro Flex*	DuraVent FasNSeal Flex*
NPE-150S2, 180A2/S2, 210A2/S2	2 in.	50 ft	n/a	35 ft
	3 in.	100 ft	100 ft	n/a
NPE-240A2/S2	2 in.	n/a	n/a	35 ft
	3 in.	100 ft	100 ft	n/a

\* List of approved materials can be found on page 52.

- Only the flexible vent models listed above are approved for use with this appliance.
- All flexible vent pipe must be installed VERTICALLY through the roof. No horizontal terminations are permitted.
- Use a 2 in. snap fit coupler or the InnoFlue® Single Wall Residential vent pipes to connect the InnoFlue® Flex 2 in. vent pipes to the exhaust.
- After installation, ensure that the vent system is tightly sealed at the joints.
- All installations using the flexible vent materials must be in INDIRECT vent applications only.
- Refer to the vent manufacturer's literature for detailed information and guidelines.

### Outdoor Installation

Outdoor installation should only be considered in mild climates. Freezing temperatures or contaminated air can damage the water heater. When installing the water heater outdoors, maintain clearances from building openings, as described in the "Non-Direct Venting (Single Pipe)" section on page 49. Outdoor installation areas should be in an open, unroofed area and should allow for the following minimum clearances from the water heater:

### 3.7 Connecting the Power Supply

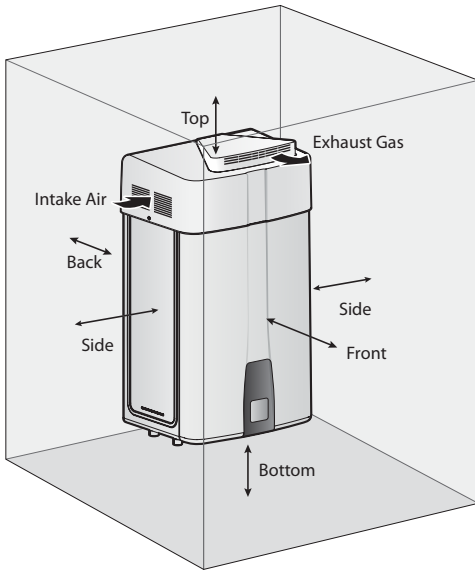

Bottom	12 in.
Back	0.5 in.
Sides	3 in.
Front	24 in.
Top	36 in.

When installing a water heater outdoors, follow these guidelines:

- The Navien Outdoor Vent Kit must be used to ensure proper operation of the water heater.
- Ensure that there is plenty of clearance around the air intake and that it is adequately protected to prevent any debris, liquids, or flammable gases from entering the air intake.
- If the water heater is installed under an eave, maintain a clearance of 3 ft or more from the eave to the top of the water heater vent terminals.

\* Refer to Navien Outdoor Vent Kit installation instructions for additional guidelines.

#### **⚠ WARNING**

##### **Electric Shock Hazard**

To prevent serious injury or death:

- ALWAYS follow all applicable electrical codes of the local authority having jurisdiction.
- In the absence of such requirements, follow the latest edition of the National Electrical Code (NFPA 70) in the USA or the latest edition of CSA C22.1 Canadian Electrical Code Part 1 in Canada.
- ONLY licensed professionals should connect the power supply.

When connecting the power supply, follow these guidelines:

- Do not connect the electric supply until all plumbing and gas piping is complete and the water heater has been filled with water.
- Connect the water heater to a 110 - 120 V AC power supply at 60 Hz. Do NOT connect the water heater to a 220 - 240 V AC power supply. Doing so will damage the water heater and void the warranty.
- All water heaters come with a factory-installed 5 ft (1.5 m) long, 3-pronged (grounded) plug. The water heater can be plugged into any grounded electrical outlet nearby, as it requires only 2 - 4 Amps.
- Keep power cord free of dust.
- Do not use a broken or modified power cord.
- Do not bind, bend or stretch power cords.

## CAUTION

Ensure that the power supply to the water heater is disconnected to prevent injury due to electrical shock.

If local codes require the water heater to be wired directly, remove and discard the factory-installed plug. See below for recommended procedures:

- Cut the existing power cord about 2" below the bottom of the junction box. Dispose the power cord.
  - Open the front cover by removing the 4 screws to access the inside of the water heater.
  - From inside the case, locate the BLACK (hot), WHITE (neutral), and GREEN (wires) that are connected to the disposed power cord. Cut these wires as close as possible to the end of the power cord where it is uninsulated.
  - These wires can be directly spliced with an external power supply. Strip approximately ½" of sheathing from each wire to expose the bare wire.
  - Connect 110-120V AC power directly to the exposed wiring using field supplied twist-on wire connectors (or wire nuts).
- Install a power switch between the breaker and the water heater to facilitate end-user maintenance and servicing. Connect the water heater to a 110 - 120 V AC power supply at 60 Hz with a maximum of 2 A (4 A if an external pump is connected) rating electrical supply.
  - The water heater must be electrically grounded. If using the power plug, ensure that the electrical outlet you connect the water heater to is properly grounded. If wiring the water heater directly to a power supply, do not attach the ground wire to either the gas or the water piping as plastic pipe or dielectric unions may prevent proper grounding.

- We recommend using a surge protector to protect the water heater from power surges.
- If there is a power failure in cold weather areas, the freeze prevention system in the water heater will not operate and may result in freezing of the heat exchanger. In cold weather areas where power failures are common, you must completely drain the water heater to prevent damage if the power will be off for any extended period of time. A battery back-up or generator may be used to supply hot water during periods of power outages. Damage caused by freezing temperatures due to power loss is not covered under warranty.
- The use of extension cords is not recommended.

If you are not using your water heater for a long period of time:

1. Completely drain the water out of the water heater.
2. Disconnect the power supply to the water heater. This prevents your water heater from freezing and being damaged.

## WARNING

### Electric Shock Hazard

To prevent serious injury or death:

- ALWAYS label all wires before disconnecting them when you work on the controls.
- Wiring errors can cause improper and dangerous operation.
- ALWAYS verify proper operation after servicing.

### 3.8 Setting the DIP Switches

The water heater has two DIP switch locations: on the main circuit board (PCB) and on the front panel. Each location has DIP switches that control the functionality of the water heater. Set the DIP switches appropriately, based on the installation environment.

#### 3.8.1 Circuit Board DIP Switches

The two DIP switches on the circuit board configure the water heater's model settings. These configurations are set at the factory and should not be changed.

#### 3.8.2 Setting the Front Panel DIP Switches

The two DIP switches on the front panel configure the water heater's gas type settings and Temperature Lock. The gas type configuration is set at the factory and should not be changed unless the unit has been converted for propane use.

When gas conversion is required, ensure to adjust DIP switch 1 according to the supply gas type. Refer to "8.1 Gas & High Altitude Conversion" on page 108 for more information.

The following table describes the functions of the DIP switches and their settings.

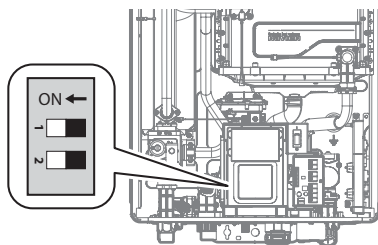

- 2-switch Panel:

Switch	Function	Setting	
1	Gas Type	Natural Gas	OFF
		Propane Gas	ON
2	Temperature Lock	Temperature can be set.	OFF
		Temperature cannot be set.	ON

### Setting Up the Altitude

1. Press and hold the Menu button (M) and the Back button (←) simultaneously for 3 seconds on the front panel to access the Service/Installer menu.
2. Select **1. Installer Menu > 2. Parameter Settings > 14. Altitude Setting** by pressing the OK button (OK) and set up the altitude.

Function	Menu	Description
Altitude Setting	1. Installer Menu	1. 0-2,000 ft
	1.2. Parameter Settings	2. 2,000-5,400 ft
	1.2.14. Altitude Setting	3. 5,400-7,700 ft
		4. 7,700-10,100 ft

#### Note

When prompted, please confirm the installation elevation by using the provided QR code. You can also access the following website (<https://www.navianinc.com/elevation>) and enter the proper zip/postal code.

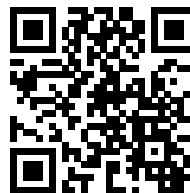

\* Natural gas units require the use of a high altitude conversion kit if installed at an elevation of 5,400 ft (1,646 m) or higher.

## **WARNING**

- ALWAYS install the High Altitude Conversion Kit if needed based on the elevation of the installation location.
- For use with Propane (LP) gas, the Propane Gas & High Altitude Conversion Kit **MUST** be used for elevations **up to 10,100 ft.**
- The Natural Gas High Altitude Conversion Kit is located inside the water heater cabinet. You will need to remove the front cover to access the Natural Gas High Altitude Conversion Kit.
- Refer to the Natural Gas High Altitude Conversion Guide and verify the orifice is appropriate for the water heater. Replace the orifice following the Natural Gas High Altitude Conversion Guide instructions if required.

### Natural Gas Orifice Identification

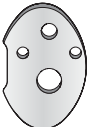
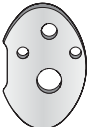

Model Type	Gas Type	Altitude	Orifice	Orifice Size	
NPE-150S2	Natural Gas	0 - 5,399 ft		Ø6.30	
		5,400 - 10,100 ft		Ø6.50	
NPE-180A2/S2		0 - 5,399 ft		Ø4.50 / Ø6.30	
		5,400 - 10,100 ft		Ø4.65 / Ø6.50	
NPE-210A2/S2 NPE-240A2/S2		0 - 5,399 ft			Ø4.80 / Ø7.50
		5,400 - 10,100 ft			Ø5.05 / Ø7.75

## 4. Configuring the Remote Controller System

### Remote Controller System (optional)

#### 4.1 Included Items

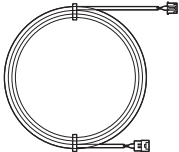
When you open the box, you will find the following items with the remote controller. Check the box for each of the following items before installing the remote controller.

	
Remote Controller	Extension Cable
	
2 Tapping Screws	Wall Mounting Bracket

#### 4.2 Accessories

The following optional accessories are available for the remote controller.

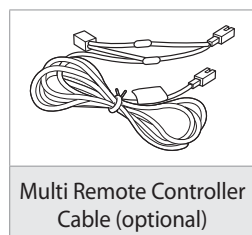

#### 4.3 Connecting the Extension Cable

1. Connect one end of the extension cable to the port on the front panel of the water heater.
2. Pass the other end of the extension cable through the hole in the bracket.

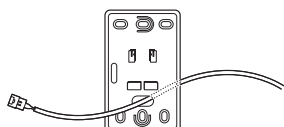

3. Connect the end of the extension cable to the cable connected to the remote controller.

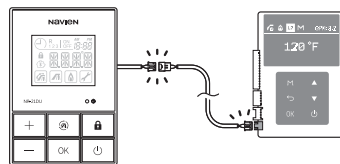

#### Note

- You can connect up to 2 remote controllers if necessary. (Optional)

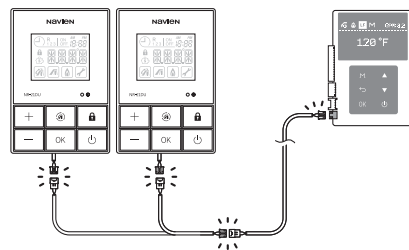

- Connect the wiring from the second remote **in parallel** with the existing remote controller. One remote must also be designated as the main controller. For more information, refer to "4.6 Multi Remote Controller System" on page 65.
- The length of the extension cable is 7 ft (2 m) and can be extended using 18AWG wire up to 300 ft (91 m).

#### 4.4 Attaching the Wall Mounting Bracket



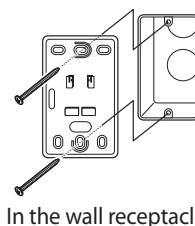
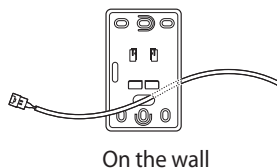



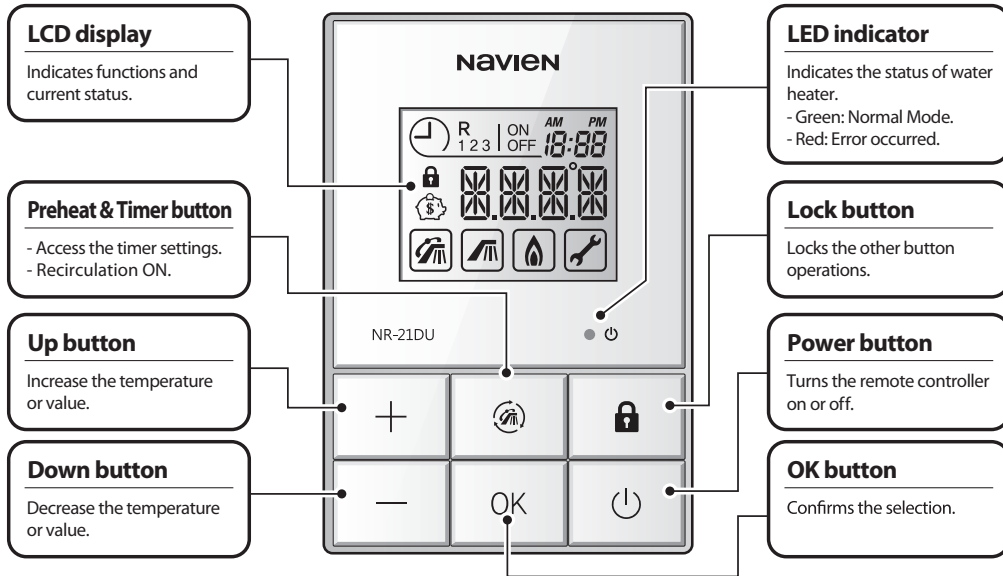

1. Affix the bracket securely to the wall by fastening 2 screws to the wall or to the 2 holes in the wall receptacle.

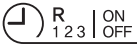

2. Hang the remote controller on the bracket by aligning the hooks.

## 4.5 Remote Controller



	Timer is set.		Recirculation Mode.
	Displays the current time.		Hot water is in use.
	Displays the current set temperature.		Water heater operation is in progress.
	Operations are locked.		An error code will appear on the display.

## 4.6 Multi Remote Controller System

The multi remote controller system (30022717A) consists of one main remote controller and one sub remote controller. The system must have only one main remote controller.

### 4.6.1 Initially Setting the Multi Remote Controller System

If you turn on the water heater with the front panel connected to two remote controllers, one of the controllers is set to the main controller randomly. The other controller will display "MAIN" on its LCD display and you have to set its operation mode to Sub.



The remote controller that does not display "MAIN" is already operating as the main controller, you don't have to set its operation mode.

You can set the operation mode of the remote controller that displays "MAIN." When you set the controller as a sub, the multi remote controller system configuration completes.

**Note**

If you press the OK button on the controller displaying "MAIN" and set its operation mode to Main while the main controller has already been determined, the other controller will display "MAIN" to indicate that you must set the main and sub operation modes properly.

1. Press the Down button on the remote controller displaying "MAIN" to set its operation mode to "SUB."



Then, press the OK button to set the operation mode to Sub.

2. "SL.xx" appears on the display. It represents the standby status to receive the sub remote controller ID from the main remote controller synced to the front panel of the water heater.



3. When the ID is assigned, the ID appears and flashes on the LCD display for 2 seconds.



4. "SYNC" appears on the LCD display for 5-10 seconds until it syncs with the connected panel and the main remote controller after the ID is assigned.



5. When the synchronization completes, identical information will appear on the displays of the main and sub controllers.

The two controllers and front panel will be controlled simultaneously by controlling only one controller.

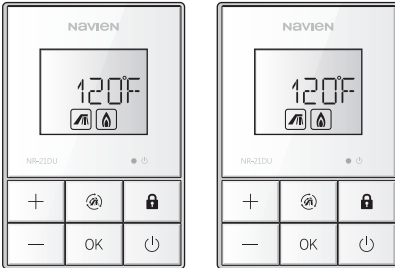

### 4.6.2 Checking the Multi Remote Controller System Setting

After completing the multi remote controller setting, you can check the setting by pressing the OK button and Lock button simultaneously for 2 seconds.

Verify that the setting is successful by confirming that one controller displays "MAIN" and the other one displays "SUB."

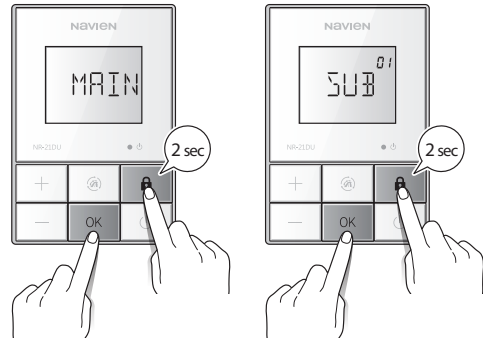

### 4.6.3 Initializing the Multi Remote Controller System Setting

You can initialize the multi remote controller system when you have to reset or replace the multi remote controllers. Press the Preheat & Timer button and Lock button simultaneously for 2 seconds on any of the controllers.

After initializing the setting, repeat the instructions from the "4.6.1 Initially Setting the Multi Remote Controller System" on page 65.

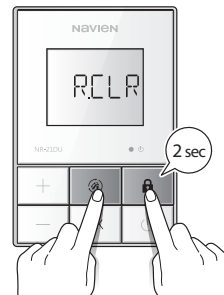

**Note**

If you initialize only one of the controllers, the other one is initialized automatically.

## 4.7 Entering Lock Mode

To prevent accidental pressing of the buttons and to prevent children from adjusting the controller, you can activate the Temperature Lock Mode.

To activate or deactivate Lock Mode, press the Lock button for 2 seconds.

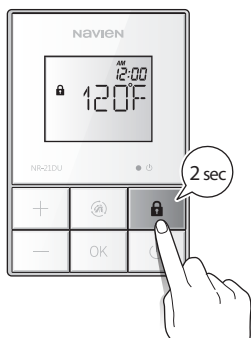

When Lock Mode is activated,

- The Lock icon appears on the display.
- All buttons except for Lock button are locked.

### Note

- Resetting errors or alarms is still available with Lock Mode activated.
- You can change the settings from the front panel with Lock Mode activated.

## 4.8 Setting the Clock

1. Press the Preheat & Timer button for 2 seconds.

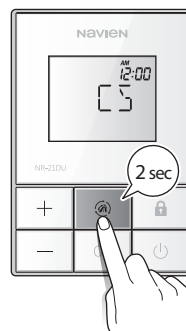

2. Adjust the minutes by pressing the Up or Down Button.

Press the OK button to set the minutes.

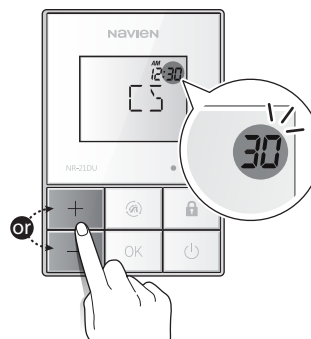

3. Once the minutes are set, adjust the hour by pressing the Up or Down button.

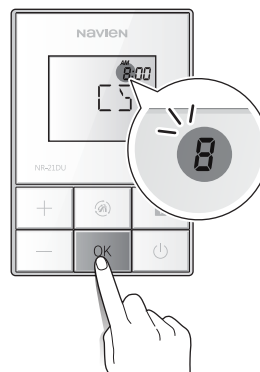

4. Press the OK button to finish and save the updated time.



2. Set the recirculation activation time by pressing the Up or Down button.

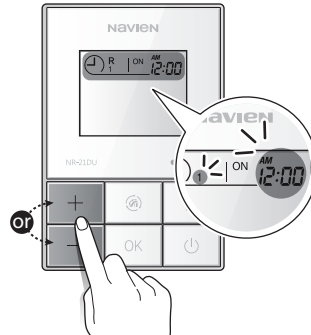

Then, press the OK button to set the deactivation time.

## 4.9 Setting the Recirculation Timer

1. Press the Preheat & Timer button to set the Recirculation timer while setting the clock. Reservation Schedule #1 is ready to be set.

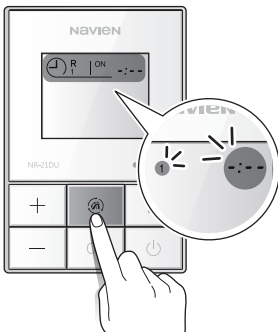

**Note**

This feature is available only when external circulating pumps are connected and ON.

**Note** The recirculation timer settings are divided in 30 minute increments.

3. Set the deactivation time by pressing the Up or Down button.

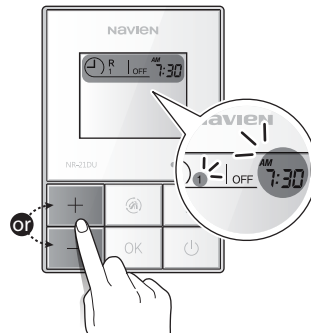

4. Press the OK button to save the timer setting. Repeat these procedures for Reservation Schedule Settings #2 and #3.



- During the reservation schedule, the preheating icon turns on and the Reservation area starts flashing.

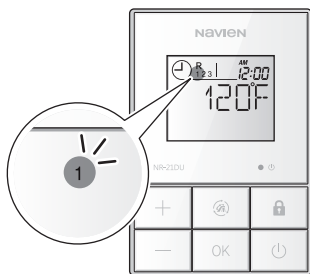

#### 4.10 Starting Recirculation

Press the Preheat & Timer button to start recirculation immediately, regardless of the reservation schedule.

“HEAT” appears for 4 seconds on the display and then recirculation runs once.



During the recirculation, the preheating icon flashes continuously.

**Note**

- This feature is available only when external circulating pumps are connected and ON.
- This feature runs during the recirculation time set on the front panel which the remote controller is connected to.

#### 4.11 Canceling all Timer Settings

Press and hold the Preheat & Timer and OK button simultaneously for 2 seconds.

“CLR” appears for 3 seconds and all timer settings are canceled.

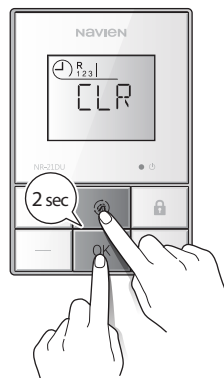

## 5. Installing a Cascade System

When installing a cascade system, carefully consider the design of the system and the features of the installation location. Follow all local codes and regulations, as well as all guidelines for installing the water heater. The following sections describe additional considerations that are specific to installing cascade systems. Read them carefully before designing or installing the system.

### 5.1 Connecting Water Supplies

Several options are available for plumbing a cascade system of water heaters. The options shown here are only examples. The setup you choose will vary based on the installation location, local building codes, and other factors. Follow all applicable regulations when installing a cascade system.

You can connect up to 32 water heaters to meet high-volume hot water demands. Some possible connection options include the following:

- Recirculation via Internal Pumps (“A2” model only):

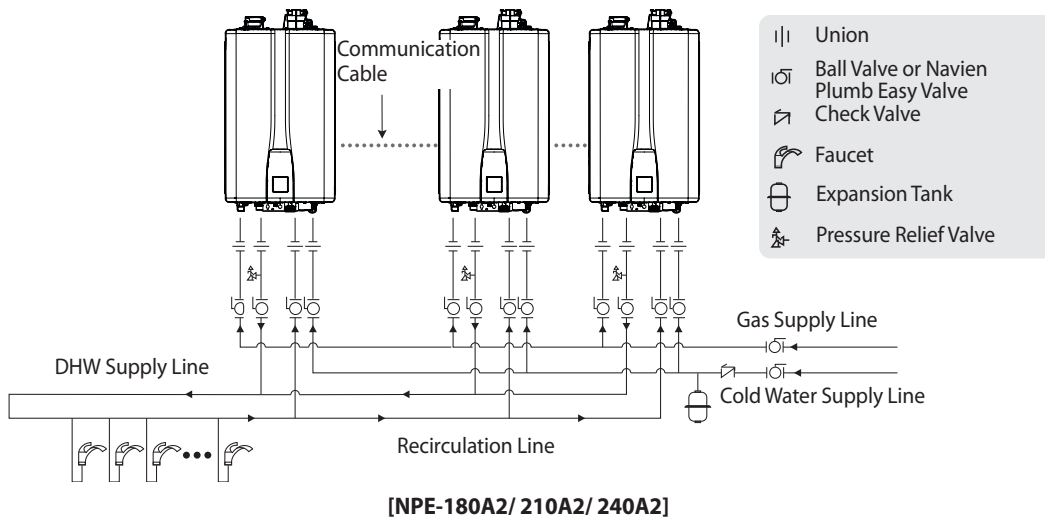

#### Note

- The recommended minimum recirculation flow rate for each water heater is 2 GPM. Depending on the number of water heaters and the diameter of the recirculation line, it may not be necessary to connect all water heaters to the recirculation line. If this is the case, set the unconnected water heaters to internal recirculation mode. The main water heater must always be connected to the recirculation line and set to external recirculation mode.
- Each unit must be configured for cascade operation.

- Multiple NPE-S2 Units:

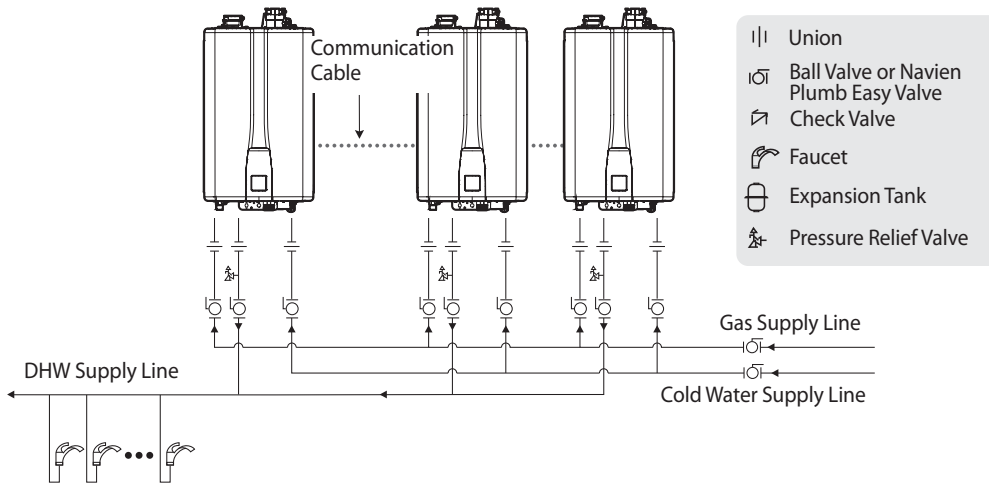

[NPE-150S2/180S2/ 210S2/ 240S2]

### 5.1.1 Piping Sizes and Considerations

When plumbing a cascade system, consider the following pipe diameters and flow rates. Note that flow rates above 6.6 ft/s may cause pipe erosion. These specifications may vary depending on installation conditions.

Qty	$\Delta T=54^{\circ}F$ Flow rate (GPM)	Water Velocity (ft/s)	Pipe Diameter (mm/in)
1	7.19	4.78	20A ¾ in.
2	14.38	5.61	25A 1 in.
3	21.57	5.54	30A 1 ¼ in.
4	28.77	5.21	40A 1 ½ in.
5	35.96	6.53	40A 1 ½ in.
6	43.15	4.49	50A 2 in.
7	50.34	5.24	50A 2 in.
8	57.5	6.00	50A 2 in.
9	64.72	4.39	65A 2 ½ in.
10	71.92	4.75	65A 2 ½ in.
11	79.11	5.34	65A 2 ½ in.
12	86.30	5.84	65A 2 ½ in.
13	93.49	6.33	65A 2 ½ in.

Qty	$\Delta T=54^{\circ}F$ Flow rate (GPM)	Water Velocity (ft/s)	Pipe Diameter (mm/in)
14	100.68	6.79	65A 2 ½ in.
15	107.87	5.11	80A 3 in.
16	115.07	5.44	80A 3 in.
17	122.26	5.81	80A 3 in.
18	129.45	6.14	80A 3 in.
19	136.64	6.46	80A 3 in.
20	143.83	6.83	80A 3 in.
21	151.02	4.06	100A 4 in.
22	158.21	4.25	100A 4 in.
23	165.41	4.45	100A 4 in.
24	172.60	4.65	100A 4 in.
25	179.79	4.85	100A 4 in.
26	186.98	5.05	100A 4 in.
27	194.17	5.24	100A 4 in.
28	201.36	5.44	100A 4 in.
29	208.56	5.61	100A 4 in.
30	215.75	5.81	100A 4 in.

**Note**

The table above is based on model NPE-240A2.

## 5.2 Connecting the Communication Cables

Up to 32 water heaters can be connected with Navien Ready-Link communication cables. Select one of the water heaters in the cascade system as the main water heater, and then connect the other water heaters to it as sub. Before making any connections, ensure that the power is turned off to all water heaters.

Connect the Ready-Link cables to the J6 ports on the left side of the front panel:

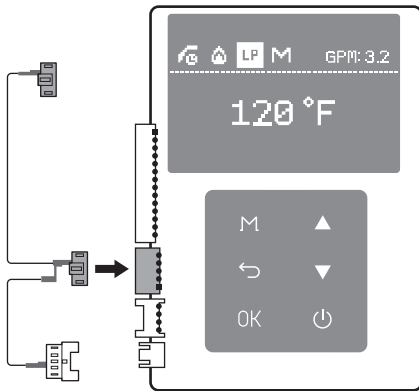

**Note** If a longer connection is required, the two can be connected and extended.

### 5.2.1 Configuring the Communication Settings

After connecting the Ready-Link communication cables, restore power to the water heater and turn on all water heaters using the Power button.

To configure the communication settings:

1. Press and hold the Menu button (M) on the main unit and the Back button (↶) simultaneously for 3 seconds on the main water heater to access the Service/Installer menu.

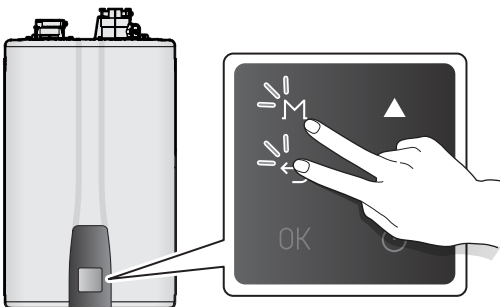

2. Select **2. Cascade Status and Set** > **3. Cascade System Setting** by pressing the OK button (OK). Then the **START** button will appear on the main water heater's front panel display. Press the OK button (OK) to start the cascade system setting.

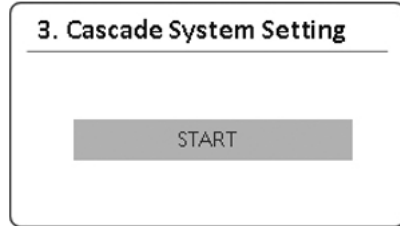

3. Press and hold the OK button (OK) for 3 seconds on the sub unit. Then, the **ID 1. Allocated!** message will appear on the sub unit's front panel display. When the water heater is set to a sub unit, the **S** icon will appear on the display.

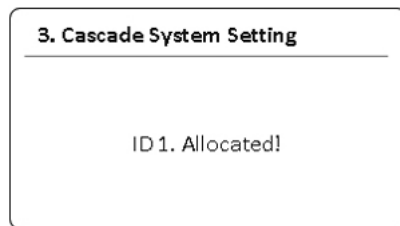
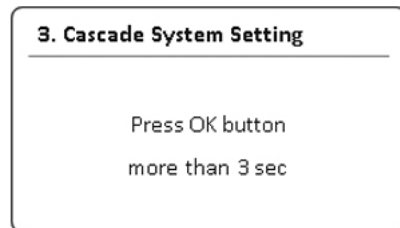

4. Repeat step 3 to configure the rest of the sub water heaters in the system.

- After an ID is assigned to each sub unit, press the OK button (OK) on the main unit. The temperature information on the main unit's display will sync with the sub unit's display.

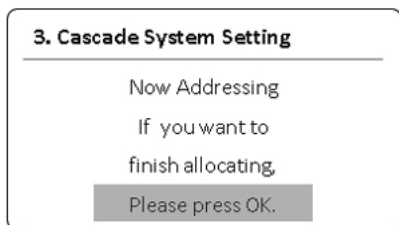

**Note**

- To add additional sub units later, repeat step 3.
- To cancel the cascade setup, press and hold the Menu button (M) and the Back button (←) simultaneously for 3 seconds to access the Service/Installer menu. Then select **2. Cascade Status and Set >** **4. Cascade System Removal.** Now the water heaters will operate independently.
- To reassign a main unit, repeat steps 1 - 5.

### 5.2.2 Multiple Unit Series Cascade Settings

The Cascade Protocol Setting allows previously discontinued models (NR/NP/NPE Series) to operate with the NPE-2 Series water heaters in a multi-unit system.

**Note**

For cascade systems, the NR/NP/NPE must be set as the MAIN unit while the NPE-2 designated as a SUB unit.

Unit Combinations	Main Unit Assignment	Sub Unit(s) Assignment	Cascade Protocol Setting
Water Heaters			
NPE + NPE-2	NPE	NPE-2	NPE
NPE + NPE-2 + NR or NP	NR or NP	NPE, NPE-2	NR
NPE-2 + NR or NP	NR or NP	NPE-2	NR

## 6. Installing a Common Vent System

### 6.1 About the Common Vent System

The Navien Common Vent System\* provides an easy way to install the vent system for up to 12 Navien NPE water heater units. By sharing the main intake and exhaust vent pipes, effective system venting is available with less venting materials and minimal number of penetrations on the walls or roofing.

\* Independently tested and approved by CSA

Read all safety messages and carefully follow the guidelines in this manual when installing a common vent system for the Navien NPE water heater units.

#### **DANGER**

This appliance is certified as a “Category IV” appliance and requires a special venting system. The vent system operates with a positive pressure in the pipe.

To prevent serious injury or death:

- ALWAYS vent exhaust gases directly outdoors using the vent materials and following these instructions.
- DO NOT connect vent connectors serving appliances vented by natural draft into any portion of mechanical draft systems operating under positive pressure.

#### **WARNING**

Improper venting of the water heater can result in excessive levels of carbon monoxide and can lead to serious injury or death.

This water heater must be vented in accordance with the “Venting of Equipment” section of the latest edition of the ANSI Z223.1/NFPA 54 Natural Fuel Gas Code in the USA and/or the “Venting systems and air supply for water heaters” section of the latest version of the CAN/CGA B149.1 Natural Gas and Propane Installation Code in Canada, as well as all applicable local building codes and regulations.

To prevent serious injury or death:

- ONLY licensed professionals should install venting.
- ALWAYS follow all regulations, codes, and instructions when venting the water heater.
- ALWAYS seal the venting system gastight to prevent flue gas leakage and carbon monoxide emissions.
- The building owner is responsible to maintain the exhaust and intake terminations free of snow, ice, or other potential blockages, as well as scheduling routine maintenance.

## 6.1.1 Guidelines for a Common Vent System

### **WARNING**

- To ensure the correct operation of the common vent system,
  - a cascade communication cable **MUST** be installed between all units in the common vent system by the installer.
  - the Navien Common Vent Collar Kit must be installed in the exhaust duct of each water heater unit.
  - use **direct vent** (with separate intake and exhaust lines) or **indirect vent** (combustion air drawn from room) systems.
  - do not mix different model units within one common vent system. Model types of all the water heater units in a common vent system must be identical.
- This section covers the installation of a common vent system for **NPE water heaters only**.

To ensure the safe and correct installation of the common vent system, carefully follow the instructions and guidelines.

- Check to see if all contents are included in the package (refer to the "Included Items" on page 80).
  - A maximum of 12 NPE water heaters may be connected to one common vent system. In a cascade system that has more than 12 water heaters, use 2 common vent systems, or consult Navien.
  - The common vent system with NPE water heaters is approved for installations at altitudes up to 10,100 ft (3078 m). Do NOT install this water heater at altitudes above 10,100 ft (3078 m).
  - Use the proper PVC cements and adhesives that are recommended for use by the pipe manufacturer.
  - Position the water heater units as close as possible to the vent termination.
  - Install a new vent system with this appliance. If an existing vent system is reused, thoroughly inspect it for punctures, cracks, or blockages prior to connecting it to the water heater unit.
  - The common vent system covered in this manual is approved for direct and non-direct vent applications.
- Horizontal vent pipe runs must be supported every 4 feet (1.2 m) (minimum). All vertical vent pipe runs must be supported every 6 feet (1.8 m) (minimum). Support the vent pipe with hangers at the indicated intervals or as required by local codes.
  - Install a Common Vent Collar Kit for each water heater unit. Use only the damper specified in this manual.
  - To avoid moisture and frost build-up and to maintain clearances to openings on adjacent homes, 45° elbows, 90° elbows, or tees may be attached to the end of the termination vent pipe to direct the exhaust plumes away from buildings, as long as the total allowable vent lengths, maximum number of elbows, and distances to air intake restrictions are observed.
  - If the water heater units will be installed in areas where snow is known to accumulate, protect the vent termination from blockage. Ensure that the vent termination is at least 12 in. (305 mm) above ground, 12 in. (305 mm) above the highest anticipated snow level, or as required by local codes, whichever is greater. Snow removal may be necessary to maintain clearance.
  - The vent for this appliance shall not terminate over public walkways; or near soffit vents or crawl space vents or where condensate or vapor could create a nuisance or hazard or cause property damage; or where condensate or vapor could cause damage or could be detrimental to the operation of regulators, relief valves, or other equipment.

## Clearances Between Multiple Units

Ensure that the installed water heaters satisfy all installation clearances provided in the manual. It is essential that there is sufficient clearance space for the common vent system to work properly.

The water heater units can be mounted either IN-LINE or BACK TO BACK.

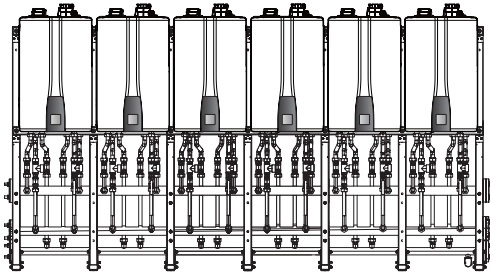

[Navien Modular Configuration with Rack System]

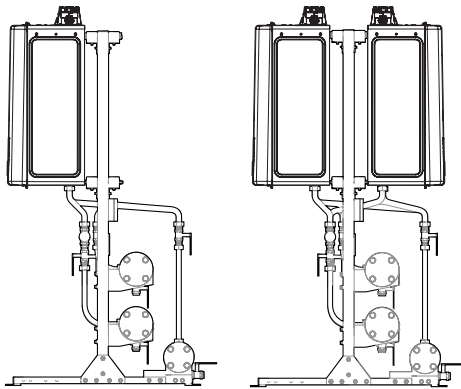

[In-line Setup]

[Back to Back Setup]

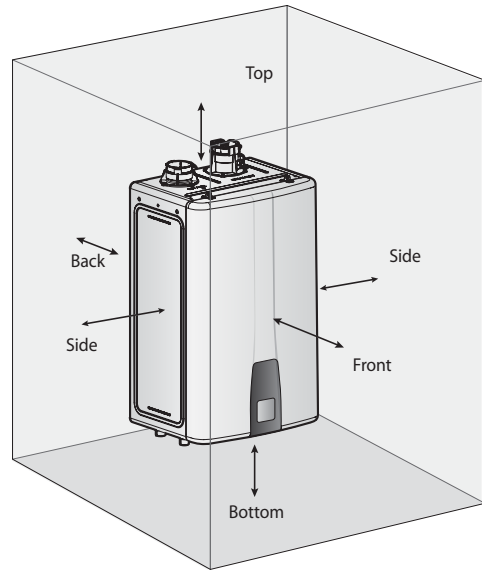

[Clearance Chart for Common Vent Applications]

Bottom	12" (300 mm)
Back	0.5" (13 mm)
Side	3" (76 mm)
Front	4" (100 mm)
Top	9" (229 mm)

### Note

The recommended clearance from the TOP of the unit is 36" for servicing the common vent.

Additionally, the recommended clearance from the FRONT of the unit is 24" for maintaining and servicing.

## General and Local Standards Information

When installing and operating the common vent system, the following standards and regulations must be complied with and adhered to:

- Local codes or, in the absence of local codes, the National Fuel Gas Code, ANSI Z223.1/NFPA 54.
- Appliance manufacturer's Installation Instructions.
- Regulations on the supervision of construction.
- Statutory provisions.
- Installation and service work must be carried out by licensed professionals only.

## Risk Guidelines

- Ensure that all common vent system components are manufactured and installed in accordance with valid standards, regulations, and safety engineering rules.
- To avoid risk, the common vent system must be installed and used only for the original purpose described in this manual.
- Defects or damages found in a common vent system must be addressed and repaired immediately.
- For roof or chimney modifications, refer to the relevant industrial safety regulations.
- Works on roofs and facades are dangerous. Comply with all relevant regulations.

## Cutting and Assembling Common Vent System Components

Standard tools are suitable for the cutting and assembly of common vent system components. Follow the guidelines listed below when working with the components.

- When cutting vent components, ensure that the cuts are straight. Chamfer and deburr all edges before installing the components.
- All vent joints must be sealed and airtight.
- Before operating the system, ensure that the installed vent system is clean and free of debris.
- Ensure that the vent system is rigidly supported according to the manual's instructions.

## Selecting Vent Pipe Materials

Consult the following chart or the most recent edition of ANSI Z223.1/NFPA 54, as well as all applicable local codes and regulations when selecting vent pipe materials. This appliance should be vented with materials approved for Category IV gas appliances. Do not use cellular core PVC (ASTM F891), cellular core CPVC, or Radel® (polyphenylsulfone) for the exhaust vent. See below for recommended vent materials.

Locale	Recommended Vent Materials
USA	<ul style="list-style-type: none"> <li>• PVC Schedule 40 (Solid Core)</li> <li>• CPVC Schedule 40 or 80 (Solid Core)</li> <li>• UL1738 approved PVC or CPVC</li> <li>• Centrotherm Innoflue Polypropylene</li> <li>• Approved Stainless Steel</li> </ul>

Locale	Recommended Vent Materials
Canada	ULC-S636 Type BH Special Gas Vent <ul style="list-style-type: none"> <li>• Class IIA (PVC)</li> <li>• Class IIB (CPVC)</li> <li>• Class IIC (Centrotherm Innoflue/ Approved Stainless Steel)</li> </ul> (Refer to page 52.)

## Vent Pipe Pitch and Supports

For the horizontal section of the common vent, slope the pipe downward toward the closest condensate drain at a rate of ¼" per foot (2% slope).

## Connecting Pipes with Cement

### WARNING

#### Carbon Monoxide Hazard

To prevent serious injury or death:

- ONLY use approved venting materials.
- NEVER mix different types of vent pipe materials. The vent system may fail and harmful flue products may leak into the living space.
- The use of more than one type of pipe for the vent piping will void the warranty and certification of the water heater.

### WARNING

ALWAYS ensure your work area is well ventilated or wear an approved organic vapor respirator when working with primers and solvent cements to prevent serious injury or death.

The vapors from primers and solvent cements can cause nausea and other health effects, including death.

To connect the vent pipes using cement:

1. Spread an even layer of solvent cement on the inside of the pipe fitting and the outside of the pipe.

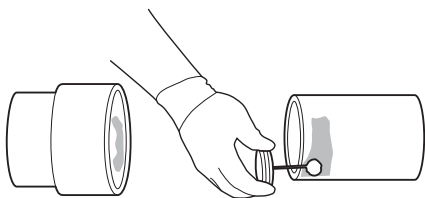

2. Align the pipe with the pipe fitting and twist the pipe a quarter turn as you insert it into the fitting. Twisting the pipe spreads the solvent cement evenly to ensure a solid joint.

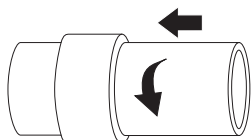

3. Hold the pipe and pipe fitting together for about 15 seconds until the cement sets.

**Note**

- Use approved solvent type cement for the proper vent materials.
- Use solvent type cement only.
- Check the date of manufacture before using the cement. Ensure that cement was not manufactured more than 2 years prior to using it.
- Ensure that the inside of the pipe fitting and the outside of the pipe, where cement will be applied, is clean.
- Apply an even layer of cement over all mating surfaces.
- Use solvent cement in room temperatures higher than 32°F (0°C).
- Use primer when required especially if temperature is below 32°F (0°C).
- Installing vent pipe with cement in cold ambient temperatures can result in longer cure times.

**⚠ WARNING**

**Carbon Monoxide Hazard**

To prevent serious injury or death:

- NEVER apply force or impact to pipes after making connections.
- Excessive force might cause the pipe or fitting to leak harmful gas.

**6.1.2 Determining the Length of a Common Vent System**

Follow the instructions listed below to determine the length of a common vent.

1. Add the BTU/H input ratings for each unit in the cascading system to determine the total BTU/H rating.
2. Determine the total length (L) of the common vent, which consists of the horizontal width (W) and the vertical height (H): Total length (L) = W + H.

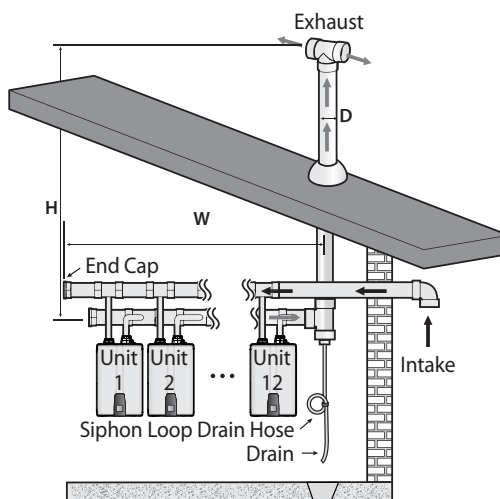

## Common Vent Length Table

[Total Length (L) = W + H]

### Vent Length for NPE Water Heater Units

Required Load (Total BTU/H)	Model	Total Length (ft)			
		NPE-240A2/S2	D=3"	D=4"	D=6"
399,800	2	60	106	200	
599,700	3	40	71	160	
799,600	4	30	53	120	
999,500	5		42	96	150
1,199,400	6		35	80	142
1,399,300	7		30	68	121
1,599,200	8			60	106
1,799,100	9			53	94
1,999,000	10			48	85
2,198,900	11			43	77
2,398,800	12			40	71

#### Note

- Every 90° elbow used is equivalent to 8 linear feet (2.4 m) of vent length.
- The maximum equivalent length of the branch pipe from the unit to the common vent trunk is 16 equivalent feet.
- Branch pipe lengths are not added to the allowable equivalent vent lengths that are provided in the following charts.
- Slope the horizontal section of the exhaust pipe downward toward the closest condensate drain at a rate of ¼" per foot (2% slope).

## Example of a Typical Installation

### (Direct & Non-Direct Vent)

The following illustration depicts an example of a common vent system installed for a cascade system of 12 Navien NPE heater units.

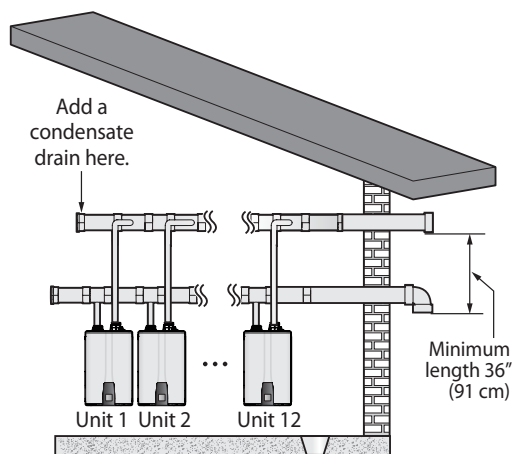
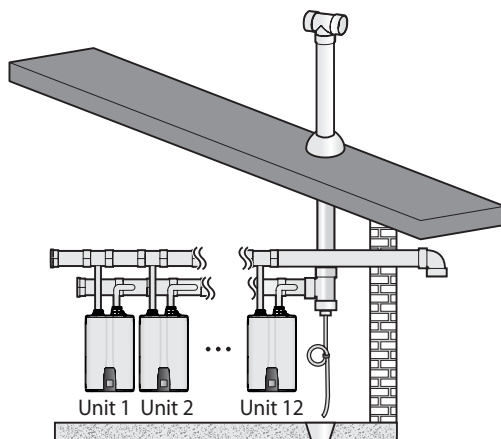

[Direct Vent]

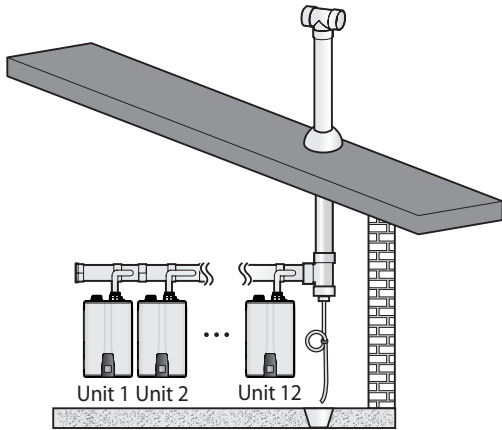

[Non-Direct Vent]

**Note** The illustration is intended for reference purposes only.

## 6.2 Navien Common Vent Collar Kit (Back-draft Damper)

The Navien Common Vent Collar Kit includes a backdraft damper preventing the flue gases and cold outside air from entering the water heater when the combustion fan is off. The kit includes the cascade cable.

By closing the exhaust vent as soon as the combustion cycle ends, the Navien Common Vent Collar Kit retains heat in the system for longer periods.

**Note** When using a common vent in a cascade system, backflow devices are required to prevent exhaust from entering the building.

### Included Items

Common Vent Collar Kit	
Installation Manual	
Ready-Link communication cable	
Screw (4 ea)	
VID jumper wire	

### Specifications

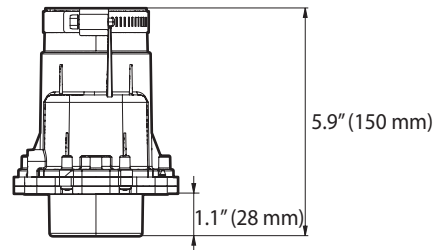

Part Name	Common Vent Collar Kit
Part No.	30014367*
Material	PP (Polypropylene)

## Maintenance Port

Navien Common Vent Collar Kit has a maintenance port to allow you to easily inspect the operating condition of the damper plate.

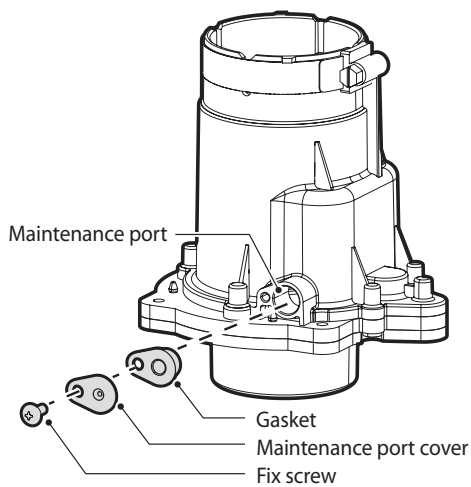
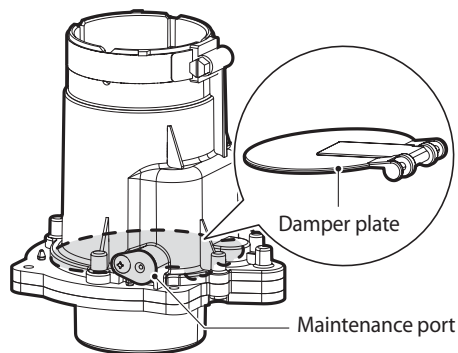

Refer to "6.8 Maintenance" for detailed inspection procedures of the Navien Common Vent Collar Kit (Back-draft Damper).

### Note

When using a common vent in a cascade system, backflow devices are required to prevent exhaust from entering the building.

## 6.3 Starting the Common Vent System

### 6.3.1 Common Vent Collar Kit Assembly

Follow the instructions below to assemble the Common Vent Collar Kit on the NPE water heater units:

1. Remove the screws from the exhaust vent adapter.

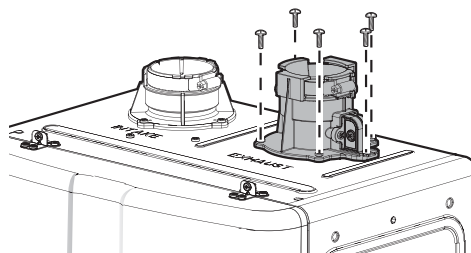

2. Open the front cover.  
Detach the exhaust vent adapter from the top of the unit. Disconnect the Vent Installation Detector (VID) wiring from the harness.

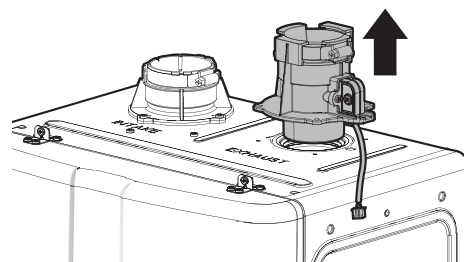

3. Connect the Common Vent Collar Kit to the exhaust duct of the water heater unit.

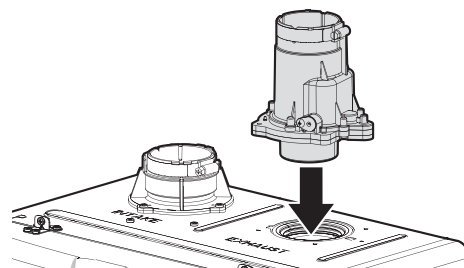

- Tighten the four mounting screws to secure the Common Vent Collar Kit in place. The screws (x 4) are supplied with the Common Vent Collar Kit.

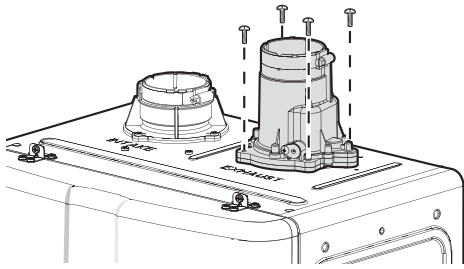

### **⚠ WARNING**

If the original vent collar must be repaired or re-assembled, ensure that it is tightened by using the 4 provided screws.

Improper installation of the vent collar may result in serious injury or death.

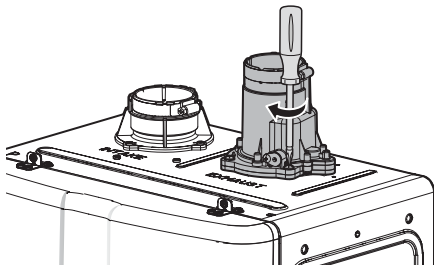

- Remove the front cover of the water heater, and connect the provided VID jumper wire as shown below. You must connect it to the wire with the "VID" label.

**Note** The Damper includes a VID jumper wire.

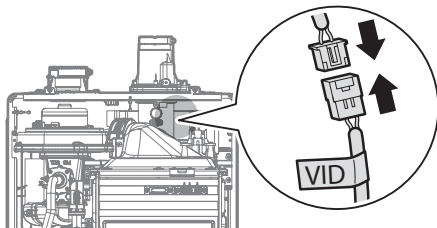

### 6.3.2 Connecting the Pipe to the Common Vent Collar Kit

#### **⚠ WARNING**

ALWAYS properly cut the pipe at a 90° angle and deburr the vent pipe before installing so the pipe is fully connected to the exhaust gas vent fitting.

Use water (NOT grease) to lubricate the end of the vent pipe before inserting into the Common Vent Collar.

ALWAYS insert the vent pipe 1.5 in. (38 mm) into the Common Vent Collar using a twisting motion until the end reaches the bottom of the socket.

If flue gas leaks, inhalation of carbon monoxide may result in serious injury or death.

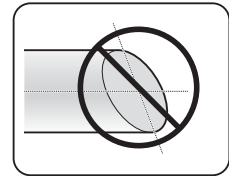
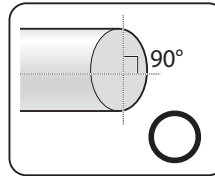
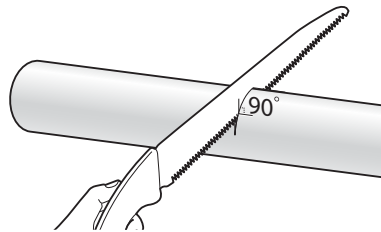

**Note** Do not use primer or cement on the appliance connection.

1. Measure 1-1/2" from the end of the vent pipe, then draw a mark at that distance.

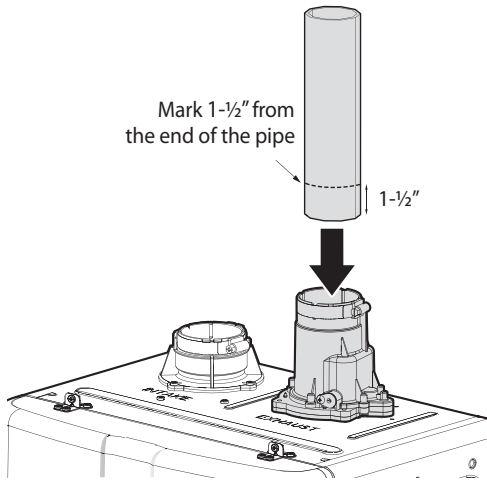

2. Insert the vent pipe into the vent collar to start the vent run. Make sure to completely slide the vent into the collar until the end makes contact with the bottom of the socket.

**Note** Verify that 1-1/2" of the pipe has been completely inserted into the collar and that the mark is no longer visible.

3. Tighten the clamp with a socket wrench (8 mm) to properly seal the joint.

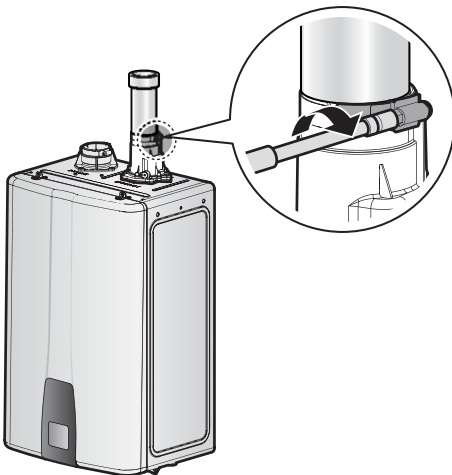

## **! WARNING**

NEVER start the vent run with a **street elbow** at the vent collar to prevent serious injury or death. Using an elbow directly at the collar will not allow for a tight seal between the appliance and the vent pipe.

ALWAYS use a length of straight pipe when starting the vent run.

**Note** The length of the vent pipe from the unit to the common vent main trunk pipe must not exceed 16' of equivalent length.

### 6.3.3 Assembling the Wye Joint

1. Assemble the hub wye, the 2" reducer, and the 90° elbow into the common vent. You can also use the hub reducing wye and the 90° elbow to assemble the common vent. Apply the proper solvent cement to the mating surfaces.

**Note** Tees can also be used instead of wye fittings as part of the common vent.

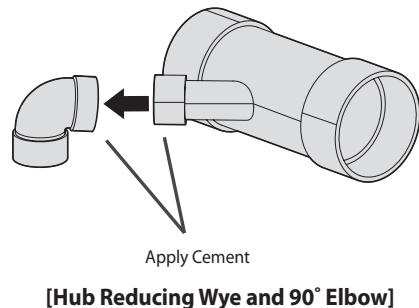
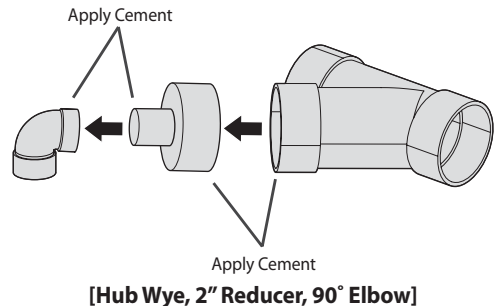

**Note**

Multiple reducers can be used to allow proper connection of 2" vent pipe to the common vent system.

2. Assemble the wye joint or wye assembly to the vent pipe. Apply solvent cement to the mating surfaces.

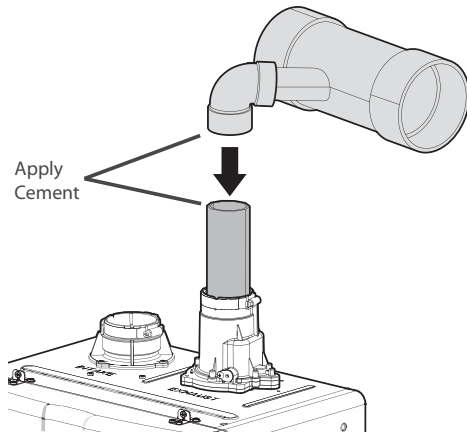

**[Hub Wye Assembly]**

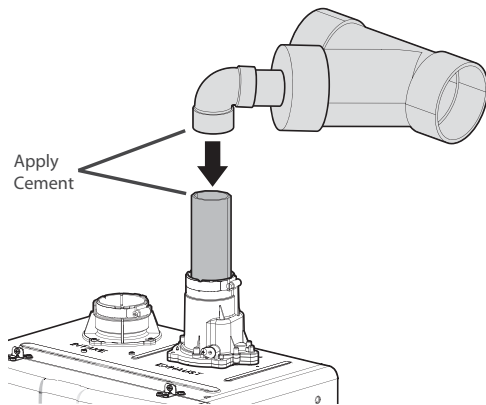

**[Hub Reducing Wye Assembly]**

**Note**

The options shown here are only examples. The setup you choose will vary based on the installation location, local building codes, and other factors. The installer is responsible for all equipment and detailing required by local codes.

## **⚠ WARNING**

### **Carbon Monoxide Hazard**

To prevent serious injury or death:

- ALWAYS use a bubble test kit to check for leaks.
- After water heater is installed, fill with water, turn on the boiler and test for leaks using a bubble test kit.
- If you see bubbles form, you will need to repair that section of pipe and bubble test again.

## 6.4 Connecting and Terminating the Vent Pipe

Refer to the following example to install the common vent system. The installation area should be measured to ensure that sufficient space is available to install the water heater units and the common vent system. Ensure that the common vent system is installed near the water heater units while satisfying all clearance requirements that are specified in this manual as well as the Installation Manuals supplied with the water heater units.

### 6.4.1 Connecting the Main Pipe Runs to Wye Joint or Wye Assembly

After connecting the wye joint or wye assembly, connect the main trunk pipe to each side of the wye joint or wye assembly. Each trunk pipe is connected to the other wye joint or wye assembly. Refer to "Connecting Pipes with Cement" on page 77 for more information.

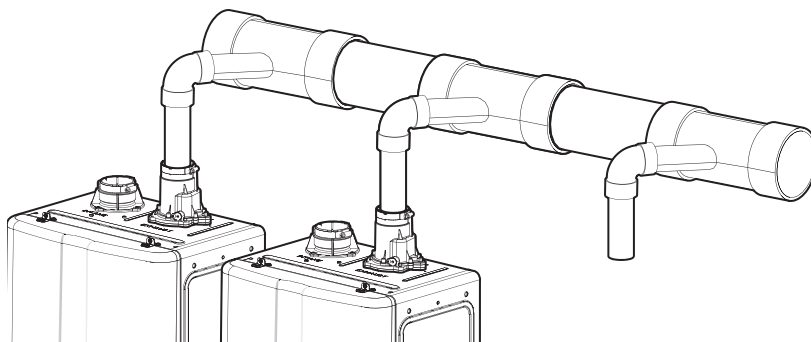

#### **⚠ WARNING**

##### **Carbon Monoxide Hazard**

To prevent serious injury or death:

- ALWAYS use a bubble test kit to check for leaks.
- After water heater is installed, fill with water, turn on the boiler and test for leaks using a bubble test kit.
- If you see bubbles form, you will need to repair that section of pipe and bubble test again.

### 6.4.2 Installing the System Termination

End caps, pipe elbows or tee joints can be used at the open ends of the intake and exhaust vent pipes. Refer to the following installation examples that depict how the parts are fitted at the end of the common vent system piping.

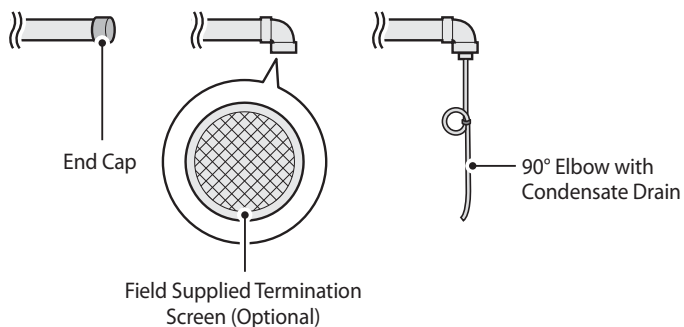

#### **Note**

The illustration is intended for reference purposes only.

## 6.5 Installing a Condensate Drain

Refer to the following examples to install a condensate drain hose (field supplied) to the common vent system. The condensate drain hose prevents condensate or rain from entering the exhaust system and gathering above the Common Vent Collar Kit. The exhaust vent must be sloped down towards the drain to prevent water from collecting within the pipe.

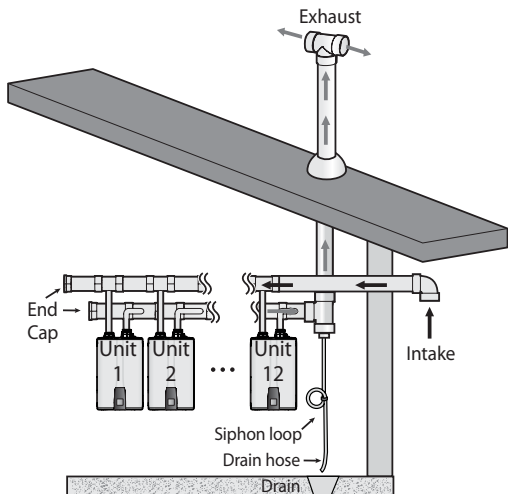
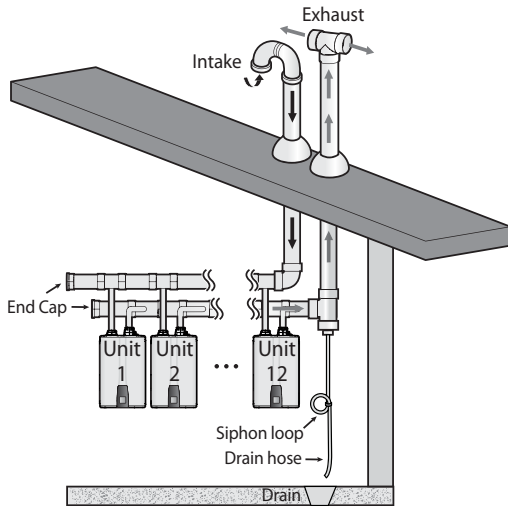

### Note

Condensate drains may also be placed at or near end cap in the above example **ONLY** if units are connected into the side of the header.

To install a condensate drain to the Common Vent system:

1. Form a loop with a drain hose and fix it with a tie.

### Note

- While shaping the hose, do not bend the hose excessively. The hose will be deformed and the flow will be restricted if the hose is bent in sharp angles.
- Do not fix the hose too tight when tying the hose to form the loop. The hose will be deformed and the flow will be restricted if the tie is too tight.

2. Prime the loop using tap water. The water inside the hose should be higher than 7.1 in. (180 mm), and water should be inside the hose before operating the water heater.
3. Install the hose to the Common Vent system and direct the end of the hose to a drain.

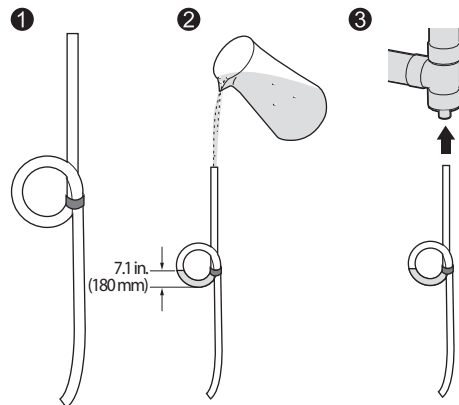

## ⚠ WARNING

### Carbon Monoxide Hazard

Check the loop again to ensure the water is still in the loop.

The loop (siphon) must be primed with water before running the system to prevent toxic exhaust gas from leaking and resulting in serious injury or death.

## 6.6 Setting up the Common Vent System

### **⚠ WARNING**

#### **Electric Shock Hazard**

To prevent serious injury or death:

- ALWAYS disconnect power before servicing.
- NEVER turn power on until the electrical wiring installation is complete.
- NEVER remove front cover unless power to unit is turned off or disconnected.

### **Setting up for a Cascade System**

1. Press and hold the Menu button (M) and the Back button (←) simultaneously for 3 seconds on the front panel to access the Service/Installer menu.
2. Select **2. Cascade Status and Set > 5. Cascade Vent Setting** by pressing the OK button (OK) and set up the common vent system for a cascade system.

Function	Menu	Description
Cascade Unit Vent	2. Cascade Status and Set 2.5. Cascade Vent setting	Common Vent Individual Vent

## 6.7 Common Vent Termination Clearances

### 6.7.1 Direct Vent Application – Vertical Installation

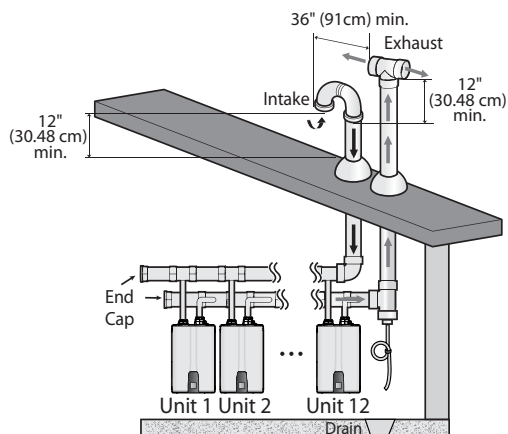

#### **Note**

For more information about the installation of the flue, refer to “3.6.6 Terminating the Vent” on page 54.

### 6.7.2 Venting Intake and Exhaust to Different Locations

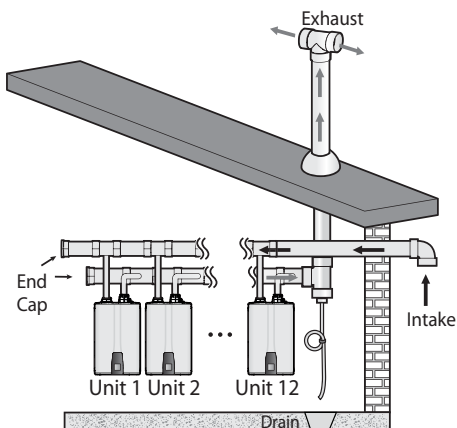

### 6.7.3 Direct Vent Application – Horizontal Installation

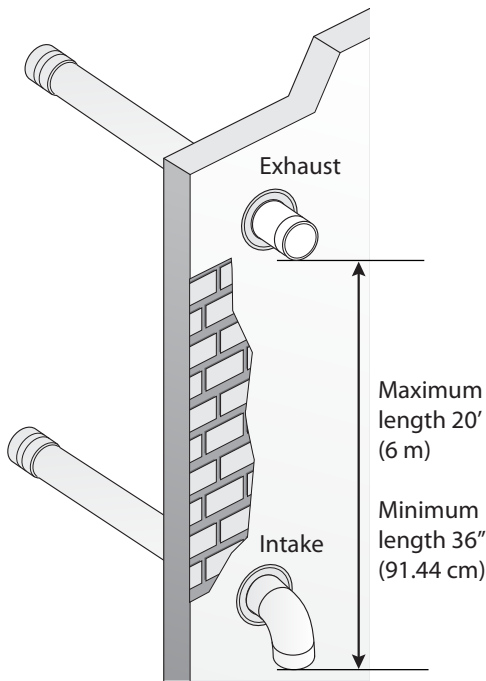

#### Note

- The illustration is intended for reference purposes only.
- Direct the exhaust away from any building openings.
- During cold weather situations, the temperature of the exhaust will be much warmer than the ambient air. Therefore, you will see water vapor being produced at the termination.

## 6.8 Maintenance

Periodically check the damper condition inside the Common Vent Collar Kit through the maintenance port to ensure optimal performance of the system. Follow the instructions to check the damper condition and replace the Common Vent Collar Kit if necessary.

1. Remove the screw that fixes the maintenance port cover to the Common Vent Collar Kit, and then remove the gasket and the maintenance port cover.

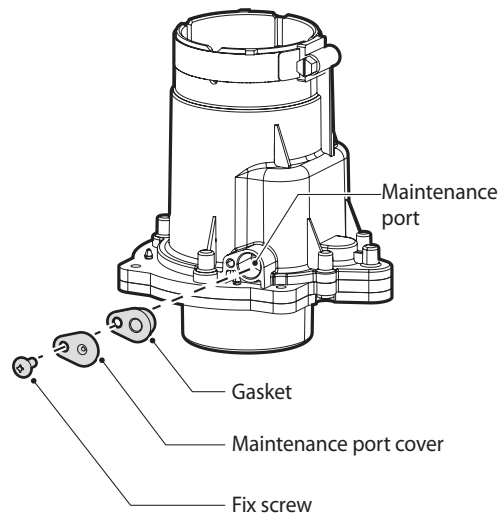

2. Through the maintenance port, check the operating condition of the damper plate inside the Common Vent Collar Kit.

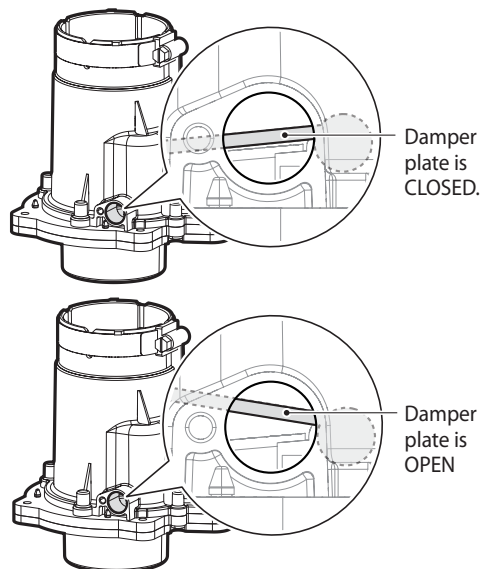

3. Reinstall the gasket and maintenance port cover, and then fix them with a set screw.

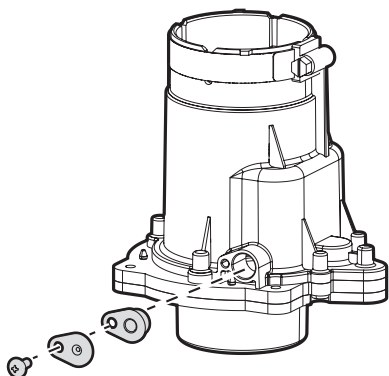

**Note** If condensate comes out the port when opened, check for proper drainage or any blockage.

4. Visually inspect the maintenance port to ensure that the gasket is properly installed between the maintenance port and the maintenance port cover.

## **⚠ WARNING**

### **Carbon Monoxide Hazard**

To prevent serious injury or death, ALWAYS check that the gasket is properly installed under the maintenance port cover after checking the operating condition of the damper plate through the maintenance port.

Harmful exhaust gas may leak if the gasket is not installed, or if it is not installed properly.

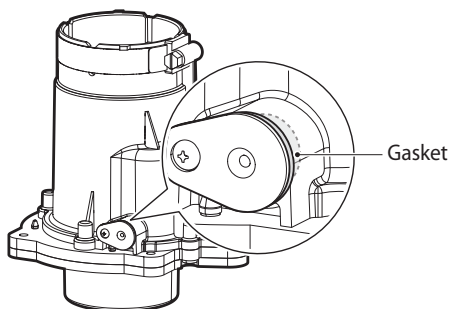

## 7. Operating the Water Heater

### **⚠ WARNING**

To prevent death, serious injury or property damage:

- Ensure the water heater is filled with water before turning on the water heater.
- If overheating occurs or the gas supply fails to shut off, shut off the gas supply to the water heater at the manual gas shut-off valve.
- If any part of the water heater has been submerged in water, do not use the water heater and immediately call a qualified service technician. The water heater must be replaced.



### 7.1 Turning the Water Heater On or Off

To turn the water heater on or off, press the Power button (⏻).

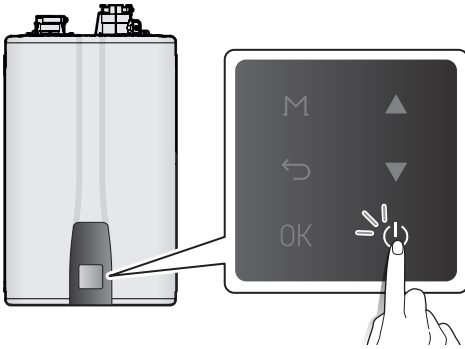

When the power is turned on for the first time, you must complete the start-up wizard. The temperature will appear on the front panel display after the power is turned on.

### 7.2 Start-Up Wizard

The setup wizard should run the first time the unit is powered on. The wizard must be completed before the water heater can be used.

1. Set the time.
  - YYYY:MM:DD:HH:MM:SS
2. Set the units to display.
  - Fahrenheit (°F), GPM, Feet
  - Celsius (°C), L/M, Meter
3. Check the gas type.
  - Natural Gas
  - Propane Gas
4. Set the installation elevation.
  - 0 - 2,000 ft (0 - 610 m)
  - 2,000 - 5,400 ft (610 - 1,646 m)
  - 5,400 - 7,700 ft (1,646 - 2,347 m)
  - 7,700 - 10,100 ft (2,347 - 3,078 m)

#### **Note**

When prompted, please confirm the installation elevation by using the provided QR code. You can also access the following website (<https://www.navieninc.com/elevation>) and enter the proper zip/postal code.

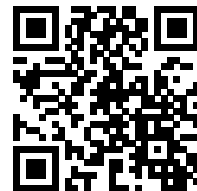

5. Select the recirculation option.
  - A2-Type: No Recir/Int.Recir/Ext.Recir
  - S2-Type: No Recir/Ext.Recir
6. Select the recirculation mode.
  - A2-Type:
    - Int.Recir (Always On/Intelligent/Weekly)
    - Ext.Recir (Always On/Intelligent/Weekly/HotButton)
  - S2-Type:
    - Ext.Recir (Always On/Intelligent/Weekly/HotButton)

**Note**

- If the weekly recirculation mode is selected, confirm all daily time settings, then press and hold the OK button (OK) for more than 2 seconds to complete the setup wizard.
- Weekly recirculation mode can NOT be adjusted using the optional remote control. The water heater front panel must be used to control the weekly settings.

7. Setup Summary

Once the Setup Wizard is finished, a summary of the settings will be displayed. Press the OK button (OK) at each summary screen until the main screen is displayed. Settings made in the Setup Wizard can be adjusted from the Main Menu and Installer Menu as described in Section 7.4 and 7.5.

## 7.3 Adjusting the Water Temperature

### **! WARNING**

Before adjusting the water temperature, read "To prevent burns:" on page 5 carefully. Water above 120 °F can cause instant scalding, severe burns, or death.

The water heater is set to 120 °F (49 °C) by default. To adjust the water temperature:

1. Make sure that all hot water faucets are closed and ensure that the internal circulator and any external circulating pumps are off.

**Note**

If a hot water faucet is open, you can adjust the temperature only from 97 - 110 °F (36 - 43 °C).

2. Press the Up button (▲) or the Down button (▼) until the desired temperature appears on the display. You can adjust the temperature while the display is flashing. Once the display stops flashing, the temperature setting is stored.

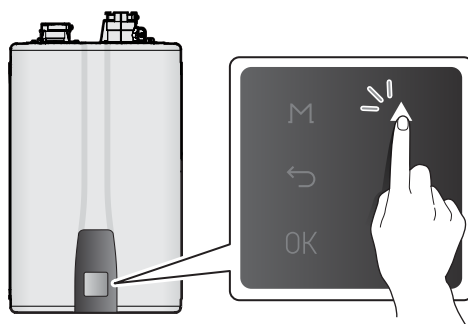

**Note**

The water heater will retain your settings during a power outage.

You can adjust the temperature by 1 degree increments as shown below, depending on the temperature range:

Temperature range	Adjusting the water temperature
97 °F - 120 °F (Fahrenheit mode) 36 °C - 50 °C (Celsius mode)	1 °F or 0.5 °C increments
120 °F - 140 °F (Fahrenheit mode) 50 °C - 60 °C (Celsius mode)	1 °F or 0.5 °C increments

The water heater will not provide hot water instantly through the hot water faucet unless a recirculation line has been installed from the furthest fixture back to the water heater. For "A2" models, the unit must be set to "external recirculation" mode.

### 7.3.1 Using Commercial Mode

To use water above 140 °F (60 °C) (up to 185 °F (85 °C)), you can use Commercial Mode.

- To enter Commercial Mode: The Temperature Lock feature must be OFF - Refer to "3.8.2 Setting the Front Panel DIP Switches" on page 61 to disable the Temperature Lock.
- Press and hold the Menu button (M) and the Back button (←) simultaneously for 3 seconds on the front panel to access the Service/Installer menu. Then access **1. Installer Menu > 2. Parameter Settings > 12. Commercial Mode** by pressing the OK button (OK). Refer to "7.5 Accessing Advanced Menu Items" on page 98 for additional information on accessing the Installer Menu.

Function	Menu	Description
Commercial Mode	1. Installer Menu 1.2. Parameter Settings 1.2.12. Commercial Mode	<ul style="list-style-type: none"> <li>• Disable: 97 °F (36 °C) - 140 °F (60 °C)</li> <li>• Enable: 140 °F (60 °C) - 185 °F (85 °C)</li> </ul>

#### Note

- To adjust the temperature in 1 °F (0.5 °C) increments, press the Up button (▲).
- The commercial warranty applies when this mode is used. Refer to the Warranty for more details.

### 7.3.2 Resetting the Water Heater

If an error message appears, you can try resetting the water heater to resolve the problem. To reset the water heater, press the Back button (←).

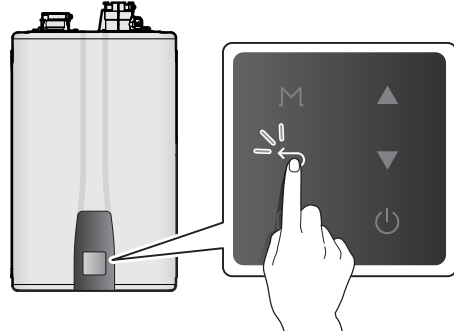

If resetting the water heater does not solve the problem, refer to "Troubleshooting" in the Owner's Manual or contact technical support at 1-800-519-8794.

### 7.4 Accessing the Basic Menu Items

To access to view the water heater's operating conditions, configure the DHW temperature, or review the error history, press the Menu button (M).

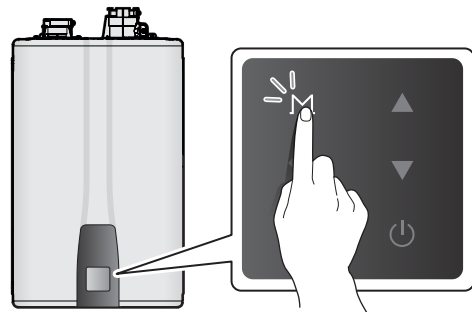

### 7.4.1 Setting the Recirculation Mode

1. Press the Menu button (M) on the front panel, and then select **1. Recirculation Settings** by pressing the OK button (OK).

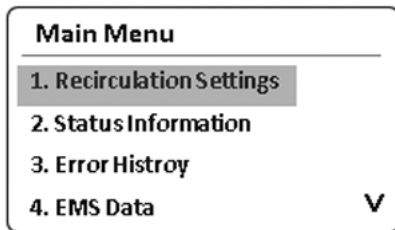
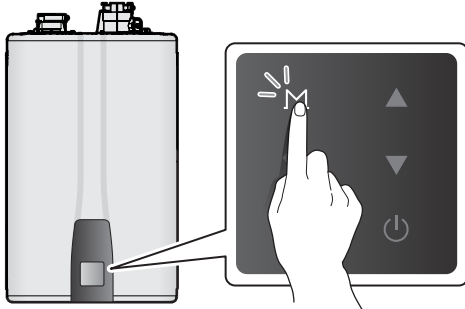

2. Press the Up button (▲) or the Down button (▼) to switch between the information items and press the OK button (OK) to select an item.

Menu	Model Type	Description
Recirculation Settings	A2-type	<p>Select <b>No Recirculation</b>, <b>External Recirculation</b>, or <b>Internal Recirculation</b>.</p> <ul style="list-style-type: none"> <li>• No Recirculation (Default): Disables recirculation.</li> <li>• External Recirculation <ul style="list-style-type: none"> <li>- Select this setting to use an external recirculation loop.</li> <li>- Select <b>Always On</b>, <b>Intelligent</b>, <b>Weekly</b>, or <b>HotButton</b>.</li> </ul> </li> <li>• Internal Recirculation <ul style="list-style-type: none"> <li>- Select <b>Always On</b>, <b>Intelligent</b>, or <b>Weekly</b>.</li> </ul> </li> </ul>
	S2-type	<p>Select <b>No Recirculation</b> or <b>External Recirculation</b>.</p> <ul style="list-style-type: none"> <li>• No Recirculation (Default): Disables recirculation.</li> <li>• External Recirculation <ul style="list-style-type: none"> <li>- Select this setting to use an external recirculation loop with pump.</li> <li>- Select <b>Always On</b>, <b>Intelligent</b>, <b>Weekly</b>, or <b>HotButton</b>.</li> </ul> </li> </ul>

3. Press the Back button (←) to exit the information view mode.

## No Recirculation

Disable recirculation.

## External Recirculation

When using the External Recirculation feature, you can choose commands in the menu to preheat according to the set DHW temperature.

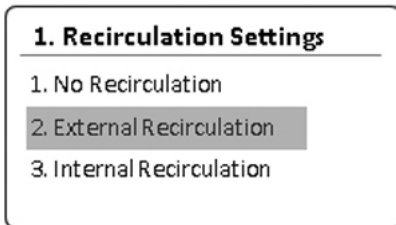

Item	Description
1. Always On	Set to repeat DHW Recirculation.
2. Intelligent*	Set to detect DHW use for a week and repeat the detected cycle.
3. Weekly*	The user can choose commands for DHW Recirculation on a weekly basis. 1. 1 Day: schedule a command for the week. 2. 3 Day: schedule commands for Weekdays, Saturdays, and Sundays. 3. 7 Day: schedule commands for each day of the week.
4. HotButton	Set to use the included HotButton controller. Refer "3.4.4 Navien HotButton Kit" on page 31.

\* To choose this option, you must set up the Time settings in the Configuration menu.

### Note

- S2-type models are automatically set to use an external pump.
- A2-type models must be set to use an external pump. When using an external pump, follow the instructions in "3.4.3 External Pump Wire Connection" on page 30 first and select **YES** on the screen asking whether the external pump is connected to the PCB.

## Internal Recirculation

When using the Internal Recirculation feature, you can choose commands in the menu to preheat according to the set DHW temperature.

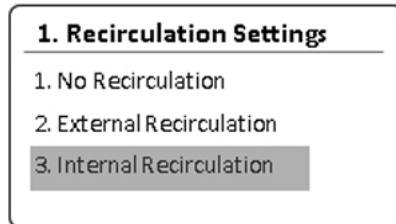

Item	Description
1. Always On	Set to repeat DHW Recirculation.
2. Intelligent*	Set to detect DHW use for a week and repeat the detected cycle.
3. Weekly*	The user can choose commands for DHW Recirculation on a weekly basis. 1. 1 Day: schedule a command for the week. 2. 3 Day: schedule commands for Weekdays, Saturdays, and Sundays. 3. 7 Day: schedule commands for each day of the week.

\* To choose this option, you must set up the Time settings in the Configuration menu.

### Note

Internal Recirculation is available only on A2-type models.

## Setting the Weekly Schedule

When setting up the Weekly option, select **Weekly**, and select **1 Day**, **3 Day**, or **7 Day** to go to the Schedule menu.

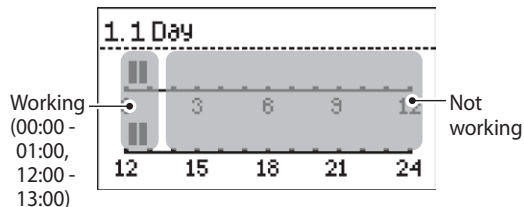

Press the Up button (▲) or the Down button (▼) to choose the scheduled time. You can choose the time in 30 minutes intervals. To finalize the weekly schedule settings, press and hold the OK button (OK) for more than 2 seconds.

**Note** Weekly recirculation mode can NOT be adjusted using the optional remote control. The water heater front panel must be used to control the weekly settings.

### 7.4.2 Viewing Basic Information

1. Press the Menu button (M), and then select **2. Status Information**.

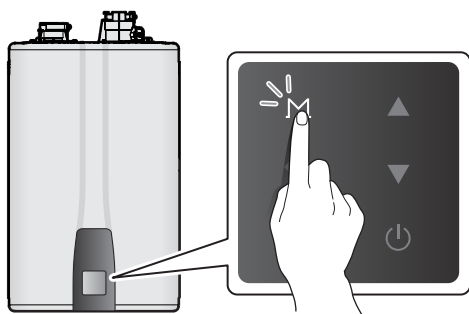

Main Menu	
1. Recirculation Settings	
2. Status Information	
3. Error History	
4. EMS Data	▼

2. Press the Up button (▲) or the Down button (▼) to switch between the information items. Press the OK button (OK) to select an item and view its information.

Item	Description
1. Operation State	Current operation state
2. Heat Capacity	Current heat capacity
3. Flow Rate	Current flow rate
4. H/Ex Flow Rate	Calculated difference produced by the OPEN condition of the mixing valve at full flow
5. Out Water Temp	Current outlet water temperature
6. In Water Temp	Current inlet water temperature
7. H/Ex Out Temp	Current heat exchanger outlet water temperature
8. H/Ex In Temp	Current heat exchanger inlet water temperature
9. Exhaust Temp	Current exhaust gas temperature
10. Water Adjust Valve	Current flow regulating valve state
11. Mixing Valve	Current mixing valve state
12. Flame Valve	Flame detection current AD value
13. Current RPM	Fan RPM
14. Current APS	APS voltage
15. HotButton Ext. Temp	Current temperature of the HotButton kit's optional external surface thermostat when the HotButton kit is connected
16. AHU Outdoor Temp	Current AHU outdoor temperature when the AHU is connected
17. AHU Outdoor SH Temp	Heating set temperature based on the current AHU outdoor temperature

Item	Description
18. AHU Comm	AHU communication state (when the AHU Comm is enabled)
19. Recirc Setting Info	Recirculation setting information
20. Recirc Ext. Pump Info	External pump use information for recirculation
21. Recirc Mode Info	Recirculation mode information
22. High Altitude	High altitude setting information
23. Model	Water heater model
24. Gas	Gas type supplied to the water heater
25. Main F/W Ver	Firmware version of the main controller
26. Panel F/W Ver	Firmware version of the panel controller

3. Press the Back button (←) to exit the information view mode.

### 7.4.3 Viewing Error History

1. Press the Menu button (M), and then select **3. Error History**.

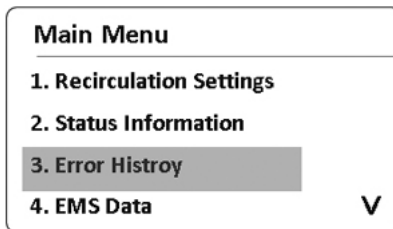
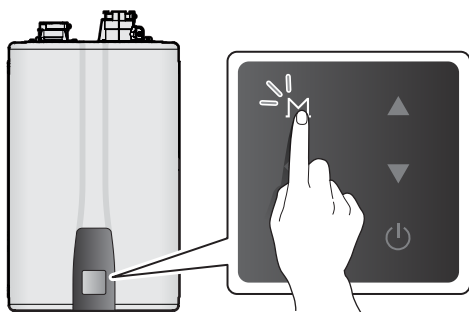

A list of 10 recent errors are displayed on the screen, with the most recent error displayed at the top of the list.

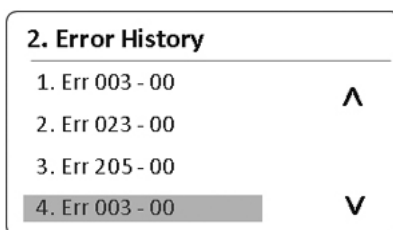

2. Press the Up button (▲) or the Down button (▼) to switch between the list of errors. Press the OK Button (OK) to select an error to view detailed information.

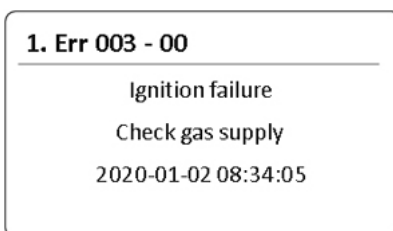

3. Press the Back button (←) to return to the previous screen or menu.

#### Note

- The front panel display flashes in red and the error icon is displayed (flashing) when a level 1 error is detected. You can press the OK Button (OK) to enter error display mode. Water Heater operation is maintained during a level 1 error.
- Level 1 errors are automatically cleared when the problem is resolved.
- You can press the Back button (←) to clear a level 1 error. The error is then cleared if the problem has been resolved.

## 7.4.4 Viewing Other System Information

1. Press the Menu button (M), and then select **4. EMS Data**.

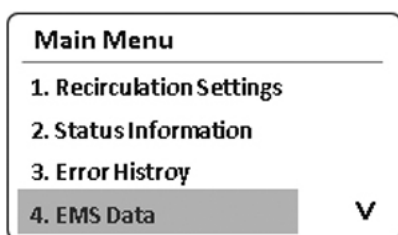
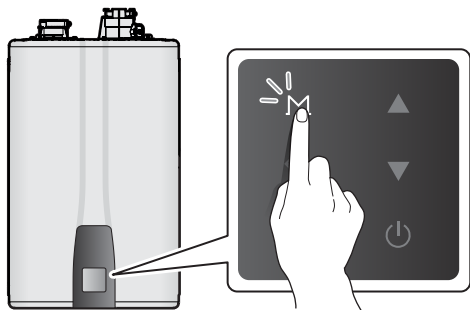

2. Press the Up button (▲) or the Down button (▼) to switch between information items. Press the OK Button (OK) to select an item to view the information.

Item	Description
1. DHW Operation Time	Monthly heating time
2. Recirc Operation Time	Monthly recirculation time
3. Gas Consumption	Monthly gas consumption

3. Press the Back button (←) to return to the previous screen or menu.

### Note

- **Gas Consumption** is calculated for the water heater only and may differ from the amount measured on the gas meter.
- **Gas Consumption** may differ from the amount measured on the gas meter due to season, gas pressure, calorific value, gas meter error, other gas equipment usage, or other variables.

## 7.4.5 Setting the Display Options

1. Press the Menu button (M), and then select **5. Configuration**.

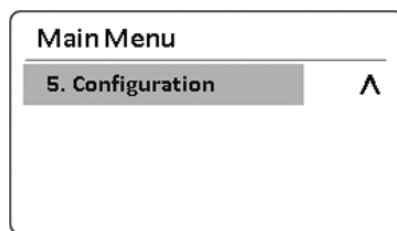
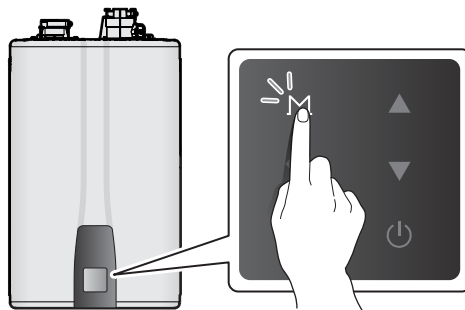

2. Press the Up button (▲) or the Down button (▼) to switch between information items. Press the OK Button (OK) to select an item to view the information.

Item	Description
1. Language	Select a display language: 1. English • Default: English
2. Display Units Setting	Set the display units. 1. °F, GPM, Feet 2. °C, L/M, Meter • Default: °F, GPM, Feet
3. Time Setting	Set the time format. • Display: YYYY.MM.DD / HH:MM:SS
4. Backlight Time Setting	Set the backlight time. • Setting range: 0 - 60 sec • Default: 10 sec

3. Press the Back button (←) to return to the previous screen or menu.

## 7.5 Accessing Advanced Menu Items

### 7.5.1 Viewing the Installer Menu

1. Press and hold the Menu button (M) and the Back button (↶) simultaneously for 3 seconds, and then select **1.Installer Menu**.

#### **CAUTION**

The Install menu must be set by a qualified professional with an extensive understanding of the water heater system. Setting parameters improperly may lead to property damage or injury.

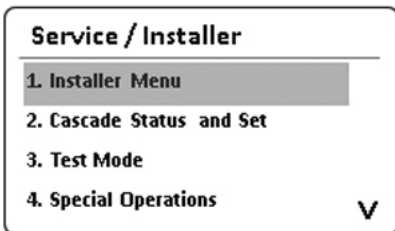
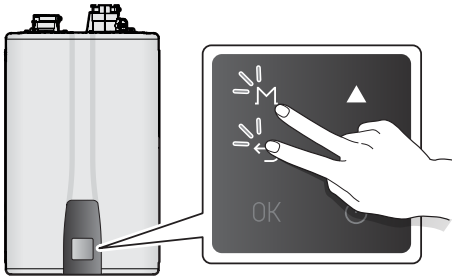

2. In the Password screen, press the Up button (▲) or the Down button (▼) to change numbers and places and press the OK button (OK) to enter the password.

The factory default password is "1234."

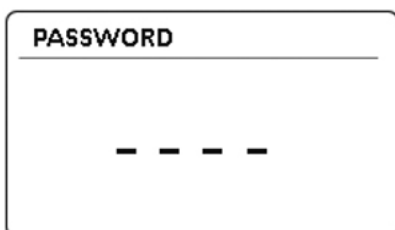

3. Press the Up button (▲) or the Down button (▼) to switch between information items. Press the OK Button (OK) to select an item to view the information.

Item	Description
1. Service Status Info	Check the operation data of the water heater.
2. Parameter Settings	Set the water heater parameters.
3. Application Setting	Set the application of the water heater.
4. Service Notif Time	Set the service notification time. <ul style="list-style-type: none"> <li>• Setting range: 0 - 3,650 days (set in 10 day increments)</li> <li>• Default: 1,820 days</li> </ul>
5. Service Contact #	View the service contact information. <ul style="list-style-type: none"> <li>• Default: 800-519-8794</li> </ul>
6. Factory Reset	Initialize all parameter settings (panel and main controller) to factory default.
7. P/W Change	Change the Installer Menu password.

#### **Note**

- If you enter an incorrect password 10 times or make no input for 1 minute, the water heater will return to Normal mode.
  - To return to the previous mode, press the Back button (↶).
  - The factory default password is "1234."
4. Press the Back button (↶) to return to the previous screen or menu.

### 7.5.1.1 Viewing Service Status Info

- From the Installer Menu, select **1. Service Status Info**.

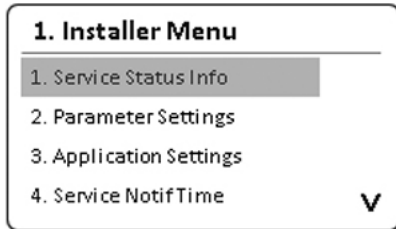

- Press the Up button (▲) or the Down button (▼) to switch between information items. Press the OK button (OK) to select an item to view its information.

Item	Description
1. Elapsed time after install	Elapsed time since water heater installation
2. DHW Op - No. of Times	Hot water usage count
3. Recirc Op - No. of Times	Recirculation usage count
4. Pump Op - No. of Times	Pump operation count
5. Flam Loss - No. of Times	Flame loss count
6. 2nd Ignition - No. of Times	2nd ignition count
7. 3rd Ignition - No. of Times	3rd ignition count
8. 4th Ignition - No. of Times	4th ignition count
9. 5 - 10th Ignition - No. of Times	5th - 10th ignition counts
10. HotButton - No. of Times	Number of stop function occurrences by temperature gap between supply and return water

- Press the Back button (←) to return to the previous screen or menu.

### 7.5.1.2 Setting the Operation Parameters

- From the Installer Menu, select **2. Parameter Settings**.

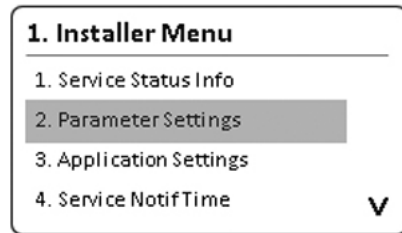

- After entering the parameter setting screen, press the Up button (▲) or the Down button (▼) to switch between the parameters or to increase or decrease setting values. Press the OK Button (OK) to select a parameter or to confirm after making changes.

Item	Description
1. Pump Exercise OP Time	Set the pump operation duration. <ul style="list-style-type: none"> <li>Setting range: 1 - 240 Sec</li> <li>Default: 30 Sec</li> </ul>
2. Pump Exercise Interval	Set the pump operation interval. <ul style="list-style-type: none"> <li>Setting range: 1 - 48 Hr</li> <li>Default: 24 Hr</li> </ul>
3. Recirc Interval Time	Set the recirculation duration. <ul style="list-style-type: none"> <li>Setting range: 1 - 120 Min - 5 Min when the HotButton kit is used</li> <li>HotButton can be set in <b>1. Recirculation Setting</b> &gt; <b>2. External Recirculation</b>.</li> <li>Default: 20 Min</li> </ul>
4. Recirc Sample Time	Set the recirculation interval. <ul style="list-style-type: none"> <li>Setting range: 1 - 120 Min</li> <li>Default: 30 Min</li> </ul>
5. Recirc Off Diff. Temp	Set the Recirculation Off offset temperature. This setting is not adjustable when the HotButton kit is used. HotButton can be set in <b>1. Recirculation Setting</b> > <b>2. External Recirculation</b> . <ul style="list-style-type: none"> <li>Setting range: 5 °F (3 °C) - 54 °F (30 °C)</li> <li>Default: 9 °F (5 °C)</li> </ul>

Item	Description
6. Exhaust Limit Control	<p>Enable or disable the exhaust limit control function.</p> <ul style="list-style-type: none"> <li>• Setting range: Enable, Disable</li> <li>• Default: Enable</li> </ul>
7. Mixing Control Mode	<p>Set the mixing control mode.</p> <ul style="list-style-type: none"> <li>• Setting range: Auto, Normal, Overshoot, Off</li> <li>• Default: Auto</li> <li>• Available on S2-type models only.</li> </ul>
8. Mixing Limit Temp Control	<p>Save or control the maximum limit temperature of the heat exchanger.</p> <ul style="list-style-type: none"> <li>• Setting range: 102 °F (39 °C) - 167 °F (75 °C)</li> <li>• Default: 131 °F (55 °C)</li> <li>• Available on S2-type models only.</li> </ul>
9. Mixing Hex Offset Temp Control	<p>Save or control the heat exchanger control offset temperature.</p> <ul style="list-style-type: none"> <li>• Setting range: 5 °F (3 °C) - 27 °F (15 °C)</li> <li>• Default: 14 °F (-10 °C)</li> <li>• Available on S2-type models only.</li> </ul>
10. Gas Use Compensation Setting	<p>Set the gas usage compensation for Navilink.</p> <ul style="list-style-type: none"> <li>• Setting range: -25% - +25%</li> <li>• Default: 0%</li> </ul>
11. Well Pump Setting	<p>Enable or disable the well pump.</p> <ul style="list-style-type: none"> <li>• Setting range: Enable, Disable</li> <li>• Default: Disable</li> </ul>

Item	Description
12. Commercial Mode	<p>Enable or disable the use of high temperature water.</p> <ul style="list-style-type: none"> <li>• Setting range: <ul style="list-style-type: none"> <li>- Enable: 140 °F (60 °C) - 185 °F (85 °C)</li> <li>- Disable: 97 °F (36 °C) - 140 °F (60 °C)</li> </ul> </li> <li>• Default: Disable</li> </ul>
13. Descaling Reminder	<p>Set the descaling reminder interval.</p> <ul style="list-style-type: none"> <li>• Setting range: No Alarm, 6 Mon, 12 Mon, 24 Mon</li> <li>• Default: No Alarm</li> </ul>
14. Altitude Setting	<p>Set the altitude.</p> <ul style="list-style-type: none"> <li>• Setting range: 1 (0 - 2,000 ft), 2 (2,000 - 5,400 ft), 3 (5,400 - 7,700 ft), 4 (7,700 - 10,100 ft)</li> <li>• Default: 1 (0 - 2,000 ft)</li> </ul>
15. Single Unit Vent Setting	<p>Unable to set.</p> <ul style="list-style-type: none"> <li>• Default: Individual</li> </ul>
16. Gas Connect Error Check Enable	<p>Enable or disable the gas connection error detecting function.</p> <ul style="list-style-type: none"> <li>• Setting range: On, Off</li> <li>• Default: On</li> </ul>

**Note**

- If you make no input for 10 seconds in the Parameter Edit mode, the current parameter value will be saved automatically.
  - Press and hold the Back button (↵) in Parameter Edit mode for 5 seconds to reset individual parameters to their default values.
3. Press the Back button (↵) to return to the previous screen or menu.

### 7.5.1.3 Setting the Application

- From the Installer Menu, select **3. Application Settings**.

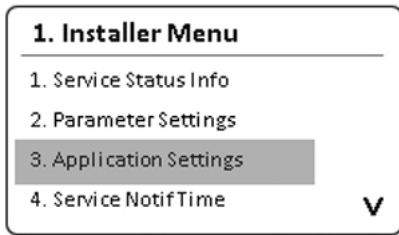

- Press the Up button (▲) or the Down button (▼) to switch between the parameters or to increase or decrease setting values. Press the OK button (OK) to select a parameter or to confirm after making changes.

Category	Item	Description
1. NaviLink	1. NaviLink Connection	Turn on or turn off the remote control capabilities via the Navi-Link connection. <ul style="list-style-type: none"> <li>Setting range: Enable, Disable</li> <li>Default: Disable</li> </ul>
2. AHU Communication	1. AHU Communication	Enable or disable the AHU link function communication. <ul style="list-style-type: none"> <li>Setting range: Enable, Disable</li> <li>Default: Disable</li> </ul>

Category	Item	Description
3. Air Handler Unit	1. AHU Burn Delay Time	Set the pump run delay time when AHU and AHU pump control are ON. <ul style="list-style-type: none"> <li>Setting range: 0 - 120 Sec</li> <li>Default: 30 Sec</li> </ul>
	2. AHU Pump Post Purge Time	Set the pump post-purge time when AHU and AHU pump control are ON. <ul style="list-style-type: none"> <li>Setting range: 0 - 120 Sec</li> <li>Default: 30 Sec</li> </ul>
	3. AHU Outdoor Low Temp	Set the outdoor low temperature when AHU and the outdoor reset function are ON. <ul style="list-style-type: none"> <li>Setting range: -4 °F (-20 °C) - 59 °F (15 °C) or [Outdoor High Temp Set-point-9 °F (5 °C)]</li> <li>Default: 14 °F (-10 °C)</li> </ul>

**Note** Air handler settings are only applicable when using the H2Air accessory.

Category	Item	Description
3. Air Handler Unit	4. AHU Outdoor High Temp	<p>Set the outdoor high temperature when AHU and the outdoor reset function are ON.</p> <ul style="list-style-type: none"> <li>• Setting range: Outdoor Low Temp+9 °F (5 °C) - 104 °F (40 °C)</li> <li>• Default: 70 °F (21 °C)</li> </ul>
	5. AHU SH MIN Set-Point	<p>Set the space heating minimum temperature when AHU and the outdoor reset function are ON.</p> <ul style="list-style-type: none"> <li>• Setting range: 100 °F (37.5 °C) - 140 °F (60 °C) or [SH Max. Set-point-36 °F (20 °C)]</li> <li>• Default: 100 °F (37.5 °C)</li> </ul>
	6. AHU SH MAX Set-Point	<p>Set the space heating maximum temperature when AHU and the outdoor reset function are ON.</p> <ul style="list-style-type: none"> <li>• Setting range: CH Min. Set-Point+36 °F (20 °C) - 185 °F (85 °C)</li> <li>• Default: 180°F (82 °C)</li> </ul>
	7. AHU 2Stage T/S Output	<p>Set the heating capacity to turn on the 2-stage T/S output when AHU is ON and 2-stage T/S output is OFF.</p> <ul style="list-style-type: none"> <li>• Setting range: Min. heating capacity - 100%</li> <li>• Default: 25%</li> </ul>

Category	Item	Description
4. HotButton (Manual recirc)	1. Fixture Distance	<p>Set the pipe length to the desired position for virtual turn-off function using the internal thermostat when the external HotButton surface temperature sensor is not installed.</p> <ul style="list-style-type: none"> <li>• Setting range: 15 ft (4.5 m) - 660 ft (198 m)</li> <li>• Default: 30 ft (9 m)</li> </ul>
	2. Recirc Interval Time	<p>Set the recirculation duration.</p> <ul style="list-style-type: none"> <li>• When the energy saver function is disabled <ul style="list-style-type: none"> <li>- Setting range: 1-120 min. (set in 1 min. increments.)</li> <li>- Default: 20 min.</li> </ul> </li> <li>• When the energy saver function is enabled <ul style="list-style-type: none"> <li>- Setting range: 1-5 min. (set in 1 min. increments.)</li> <li>- Default: 5 min.</li> </ul> </li> </ul>
	3. Recirc off Diff. Temp	<p>Set the Recirculation Off offset temperature.</p> <ul style="list-style-type: none"> <li>• When the energy saver function is disabled <ul style="list-style-type: none"> <li>- Setting range: 5 °F (3 °C)- 54 °F (30 °C) (set in 1 °F [0.5 °C] increments.)</li> <li>- Default: 9 °F (5 °C)</li> </ul> </li> <li>• When the energy saver function is enabled <ul style="list-style-type: none"> <li>- This setting is not adjustable.</li> </ul> </li> </ul>

Category	Item	Description
5. External Tank	1. External DHW Tank Setting	Set whether to use an external DHW tank. <ul style="list-style-type: none"> <li>Setting range: Enable, Disable</li> <li>Default: Disable</li> </ul>
	2. Ext. Tank Cascade Unit On Temp Offset	Set the temperature to turn on an external DHW tank of a cascade. <ul style="list-style-type: none"> <li>Setting range: Ext. Tank Cascade Unit Off Temp Offset - 54 °F (30 °C)</li> <li>Default: 13 °F (7 °C)</li> </ul>
	3. Ext. Tank Cascade Unit Off Temp Offset	Set the temperature to turn off an external DHW tank of a cascade. <ul style="list-style-type: none"> <li>Setting range: Ext. Tank Burn On Temp Offset - Ext. Tank Cascade Unit On Temp Offset</li> <li>Default: 9 °F (5 °C)</li> </ul>

Category	Item	Description
5. External Tank	4. Ext. Tank Burn On Temp Offset	Set the temperature to turn on an external DHW tank combustion. <ul style="list-style-type: none"> <li>Setting range: Ext. Tank Burn Off Temp Offset - Ext. Tank Cascade Unit Off Temp Offset</li> <li>Default: 5 °F (3 °C)</li> </ul>
	5. Ext. Tank Burn Off Temp Offset	Set the temperature to turn off an external DHW tank combustion. <ul style="list-style-type: none"> <li>Setting range: 0 °F (0 °C) - Ext. Tank Burn On Temp Offset</li> <li>Default: 0 °F (0 °C)</li> </ul>

**Note**

When you reset one of the following parameters, the corresponding parameter will be reset automatically:

- AHU Outdoor High or Low Temp
- AHU SH MAX or MIN Set-point
- Ext. Tank Cascade Unit On or Off Temp Offset
- Ext. Tank Burn On or Off Temp Offset

3. Press the Back button (←) to return to the previous screen or menu.

### **AHU Communication**

AHU Communication feature can be used when NPE and thermostat are difficult to connect.

It can be used for AHU heating with a hot water recirculation line.

**Note**

AHU has an RS-485 communication function. Its communication protocol has to match the NPE communication protocol. Refer to “8.9 AHU Application with RS-485 Communication (optional)” on page 139 for piping diagram.

## Outdoor Reset Control

**Note** The following settings including the Outdoor Reset Control are only applicable when using the H2Air accessory.

The Outdoor Reset Control feature can be used to enhance energy efficiency while maintaining optimal heating performance. Outdoor Reset Control automatically changes the space heating temperature setting based on the outdoor temperature and the current space heating system application (system load).

To achieve optimal heating performance, configure the following set-points: the Outdoor Low Temperature, the Outdoor High Temperature, the heating MIN and the heating MAX Set-point configuration must be based on the H2Air system characteristics and installation environment.

Refer to the following examples in the graph to configure the Outdoor Reset Control feature.

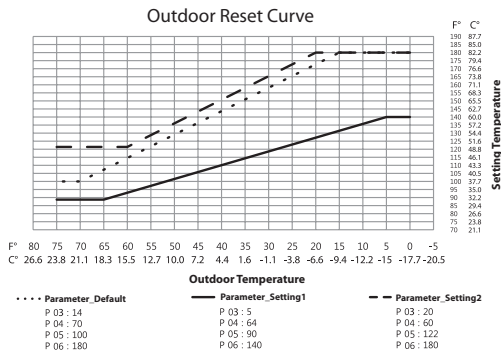

\* The graph above is an example of a few possible outdoor reset parameter settings. For more information about settings, refer to the following information.

\* If the Outdoor Reset On (H2Air DIP switch #1 OFF) is set and the outdoor temperature sensor is not connected, or the outdoor temperature sensor value is outside the normal range, the '740' error message is displayed and the system operates the same way as with the Outdoor Reset OFF (H2Air DIP switch #1 ON) setting.

**Note** The following parameters are used for the outdoor reset control:

- P.03: AHU Outdoor Low Temp
- P.04: AHU Outdoor High Temp
- P.05: AHU SH MIN Set-point
- P.06: AHU SH MAX Set-point

## 2-Stage T/S Output Heat-Capacity

Models with the 2-stage air handler control function (W1, W2) can use a 2-stage thermostat or can be automatically controlled by the H2Air controller (If the H2Air DIP switch # 3 is OFF).

When using the automatic 2-stage heating feature, the system will modulate between the 1-stage and 2-stage based on the set heat capacity parameter of the water heater. This heat capacity value can be adjusted based on the desired modulation point (default heat capacity is 25%)

**Note** The following parameter is used for the 2-stage T/S output heat-capacity:

- P.07: AHU 2Stage T/S Output

### 7.5.2 Configuring a Cascade System

1. Press and hold the Menu button (M) and the Back button (↵) simultaneously for 3 seconds and then select **2. Cascade Status and Set**.

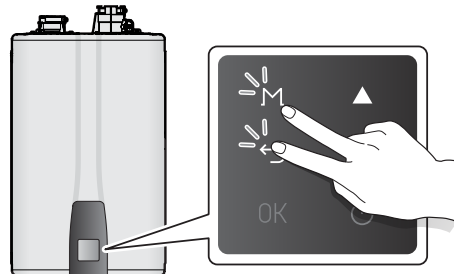

**Service / Installer**

1. Installer Menu
2. Cascade Status and Set
3. Test Mode
4. Special Operations

▼

2. Press the Up button (▲) or the Down button (▼) to switch between the parameters or to increase or decrease setting values. Press the OK button (OK) to select a parameter or to confirm after making changes.

Item	Description
1. Cascade Info	Number of an individual water heater and the status
2. Number of Oper-Unit	Number of currently operating cascade units
3. Cascade System Setting	<ul style="list-style-type: none"> <li>To enter the Cascade Setting Mode, select <b>START</b> on the main unit.</li> <li>The setting mode is entered and the IDs of all water heaters that can communicate with the main unit via the RS-485 communication line are initialized.</li> <li>The water heaters whose IDs are initialized by the main unit are set to &lt;Sub setting mode&gt;, if you press and hold the OK button (OK) for 3 seconds or more, the main unit gives you the ID and it is displayed on the front panel.</li> <li>The main unit periodically checks the RS-485 communication, and when there is an ID request from the sub unit, the ID is sequentially incremented and added to the Sub (1 to 32).</li> <li>Press the OK button (OK) in the Main to complete the cascade setting. The main unit and the sub unit with an assigned ID will return to the normal operation mode with the cascade setting ON. The  icon will appear the main unit's front panel.</li> <li>In Main setting mode, if no input is detected for 60 minutes, the water heater resumes normal operation without cascading.</li> </ul>

Item	Description
4. Cascade System Removal	<p>Execute this menu on the main unit of a cascade system to end cascade operation. All units will return to a single water heater setup.</p> <ul style="list-style-type: none"> <li>Access the <b>3. Cascade System Setting</b> to reassign IDs and begin a cascade system again.</li> <li>If a sub unit has a network communication problem, select this option on the sub unit to exclude the individual unit from the cascade system.</li> </ul>
5. Cascade Vent Setting	<p>Set the ventilation type.</p> <ul style="list-style-type: none"> <li>Default: Common Vent</li> </ul>
6. Cascade Disable	<p>On the main unit, turn on or off all units in a cascade system.</p> <ul style="list-style-type: none"> <li>You can also press and hold the Menu button (M) and the Back button (←) simultaneously for 5 seconds.</li> <li>On a sub unit, turn the unit on or off.</li> </ul>
7. Cascade init oper Number	<p>Set the number of initial activating units in the cascade system.</p> <ul style="list-style-type: none"> <li>Setting range: Auto, 1 - 32</li> <li>Default: Auto</li> </ul>
8. Cascade Min oper Number	<p>Set the minimum number of units in the cascade system.</p> <ul style="list-style-type: none"> <li>Setting range: 1 - 32</li> <li>Default: 1</li> </ul>
9. Cascade Unit ON HC Offset	<p>Set the heating capacity compensation standard when the cascade combustion is ON.</p> <ul style="list-style-type: none"> <li>Setting range: -15% - +15%</li> <li>Default: 0%</li> </ul>

Item	Description
10. Cascade Unit OFF HC Offset	Set the heating capacity compensation standard when the cascade combustion is OFF. <ul style="list-style-type: none"> <li>• Setting range: -5% - +5%</li> <li>• Default: 0%</li> </ul>
11. Cascade Protocol	Set the cascade protocol. <ul style="list-style-type: none"> <li>• Setting range: NPE, NR</li> <li>• Default: NPE</li> </ul>

3. Press the Back button (←) to return to the previous screen or menu.

### 7.5.3 Diagnosing the Water Heater System

1. Press and hold the Menu button (M) and the Back button (←) simultaneously for 3 seconds, and then select **3. Test Mode**.

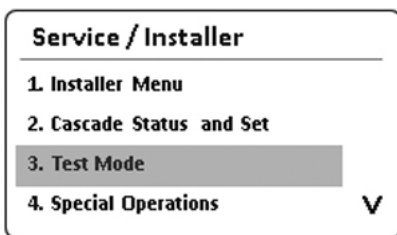
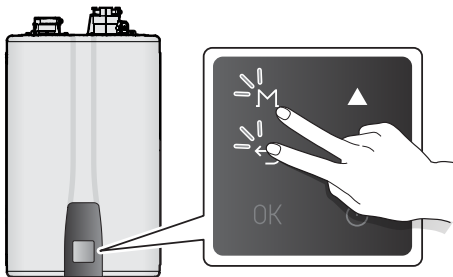

2. Press the Up button (▲) or the Down button (▼) to switch between the test procedures. Press the OK button (OK) to select a parameter or to run a test procedure.

Item	Description
1. Fan Motor	This procedure slowly increase RPM of the fan motor from 0 to the maximum and then decreases it to 0, and then repeats the same sequence.
2. Water Flow Adjust Valve	This procedure turns the valve to a fully open position and then to a full close position over approximately 12 seconds. A value between 0 - 100% will appear on the front panel. <ul style="list-style-type: none"> <li>• Check the feedback during the procedure.</li> <li>• When the procedure is complete, the valve returns to the latest status.</li> </ul>
3. Dual Venturi	The dual venturi is turned on as soon as you access the menu and switches between the on and off status as you press the Up button (▲) or the Down button (▼).
4. Pump (A2-Type) Ext.Pump (S2-Type)	Set to repeat the sequence that runs the pump for 10 seconds and stops for 5 seconds 5 times for 75 seconds.
5. Mixing Valve (S2-Type Only)	This procedure turns the valve to a fully open position and then to a fully closed position over approximately 10 seconds. A value between 0 - 56% will appear on the front panel. <ul style="list-style-type: none"> <li>• Check the feedback during the procedure.</li> <li>• Available on S2-type models only.</li> </ul>

3. Press the Back button (←) to return to the previous screen or menu.

## 7.5.4 Setting the Special Operation Mode

1. Press and hold the Menu button (M) and the Back button (←) simultaneously for 3 seconds and then select **4. Special Operations**.

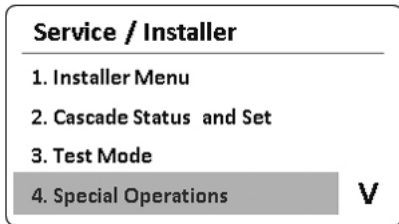
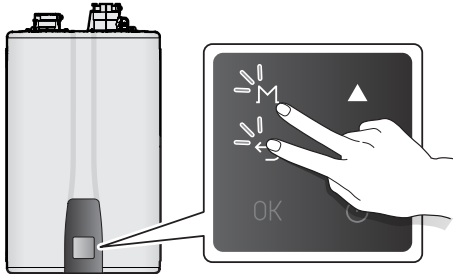

2. Press the Up button (▲) or the Down button (▼) to switch between the special operation modes. Press the OK button (OK) to select a parameter or to run a special operation mode.

Item	Description
1. Normal	Set the water heater to run in the normal mode.
2. 1 <sup>st</sup> MIN	Set the water heater to run in the 1-stage minimum operation mode.
3. 1 <sup>st</sup> MAX	Set the water heater to run in the 1-stage maximum operation mode.
4. 2 <sup>nd</sup> MIN	Set the water heater to run in the 2-stage minimum operation mode.
5. 2 <sup>nd</sup> MAX	Set the water heater to run in the 2-stage maximum operation mode.

3. Press the Back button (←) to return to the previous screen or menu.

## 8. Appendixes

### 8.1 Gas & High Altitude Conversion

This water heater is configured for Natural Gas at the factory.

- If conversion to Propane Gas is required by the water heater, use the PROPANE GAS & HIGH ALTITUDE CONVERSION KIT supplied with the water heater.
- If the water heater is installed at a high altitude (above 5,400 ft) for NG, use the NATURAL GAS HIGH ALTITUDE CONVERSION KIT supplied with the water heater.

**Note** For Propane high altitude conversion, use the PROPANE GAS & HIGH ALTITUDE CONVERSION KIT. Note that the Gas Orifice from the PROPANE GAS & HIGH ALTITUDE CONVERSION KIT covers the water heater's installation at an altitude of 0 to 10,100 ft.

#### **⚠ DANGER**

DO NOT perform a gas & High Altitude conversion without an officially approved conversion kit and the instructions supplied by Navien. Gas & High Altitude conversion using any other parts will result in extremely dangerous burner operation, leading to fire, explosion, severe personal injury or death.

**Note** High Altitude Conversion kit (a) and Propane Gas & High Altitude Conversion kit (b) are attached to the inside of Product's case.

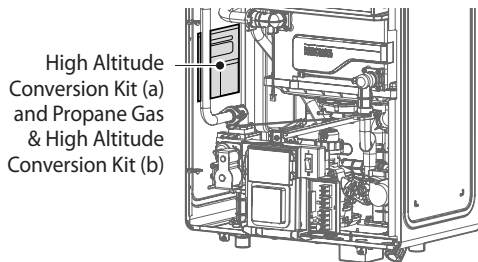

a. High Altitude Conversion Kit

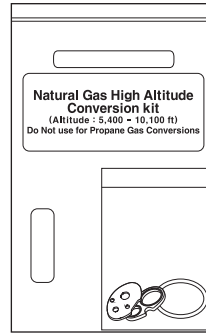

b. Propane Gas & High Altitude Conversion Kit

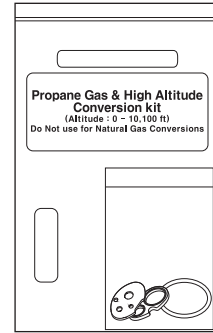

#### **⚠ DANGER**

##### Fire and Explosion Hazard

To prevent serious injury, death, or property damage:

- ONLY a qualified service agency\* is required to install a conversion kit in accordance with Navien's instructions and all applicable codes and requirements of the authority having jurisdiction.
- The qualified service agency is responsible for the proper installation of this kit. The installation is not proper and complete until the operation of the converted appliance is checked as specified in the manufacturer's instructions supplied with the kit.

BEFORE starting the gas conversion:

- ALWAYS turn off electrical power supply to the water heater and close the manual gas shut-off valve.
- ALLOW water heater to cool if it has been operating.

\* A qualified service agency is any individual, firm, corporation or company which either in person or through a representative is engaged in and is responsible for the connection, utilization, repair or servicing of gas utilization equipment or accessories; who is experienced in such work, familiar with all precautions required, and has complied with all of the requirements of the authority having jurisdiction.

**In Canada:** The conversion shall be carried out in accordance with the requirements of the provincial authorities having jurisdiction and in accordance with the requirements of the CAN B149.1 and CAN1 B149.2 Installation Code.



**Tools Required:**

- Phillips Screwdriver
- Flathead Screwdriver
- 5/32 in. or 4 mm Allen Wrench
- Combustion Analyzer or Dual Port Manometer
- Gas Leak Detector

**Included Items:**

- Gas Orifice (Table 1)
- Gas Pressure and Conversion Kit Number Labels

**NPE-150S2 Orifice Identification**

Gas Type	Natural Gas		Propane Gas
Altitude	0 - 5,399 ft	5,400-10,100 ft	0-10,100 ft
Orifice	 Factory Installed	 For High altitude	 For Propane
Orifice Size	Ø6.30	Ø6.50	Ø5.10

**NPE-180A2/S2 Orifice Identification**

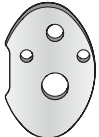
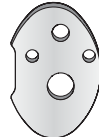
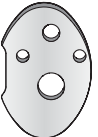
Gas Type	Natural Gas		Propane Gas
Altitude	0 - 5,399 ft	5,400-10,100 ft	0-10,100 ft
Orifice	 Factory Installed	 For High altitude	 For Propane
Orifice Size	Ø4.50 / Ø6.30	Ø4.65 / Ø6.50	Ø3.65 / Ø4.95

**NPE-210A2/S2, 240A2/S2 Orifice Identification**

Gas Type	Natural Gas		Propane Gas
Altitude	0 - 5,399 ft	5,400-10,100 ft	0-10,100 ft
Orifice	 Factory Installed	 For High altitude	 For Propane
Orifice Size	Ø4.80 / Ø7.50	Ø5.05 / Ø7.75	Ø3.90 / Ø5.65

Table 1. Orifice Size

**! DANGER**

**Fire and Explosion Hazard**

To prevent serious injury, death, or property damage:

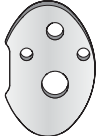
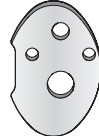
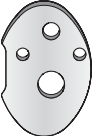
- Be careful not to confuse the PROPANE GAS & HIGH ALTITUDE CONVERSION KIT and NATURAL GAS HIGH ALTITUDE CONVERSION KIT. Do NOT use the NATURAL GAS HIGH ALTITUDE CONVERSION KIT for natural gas when converting to propane gas.
- Make sure that the conversion is completed with the proper orifice. If the installed orifice does not conform to the specifications in Table 1, incomplete combustion may occur, resulting in personal injury or property damage.

**Procedure:**

**Note** The procedure below can be applied to both Propane conversion and High Altitude conversion. Distinguish the kit supplied with the water heater before installing.

1. Turn off both gas and water supply to the water heater.
2. Using a Phillips hand screwdriver, remove 4 screws (2 from the top and 2 from the bottom) of the front cover assembly to gain access to the internal components. See Figure 1 for illustration of the front cover on the unit.



Figure 1.  
NPE-A2/S2 Series Front cover

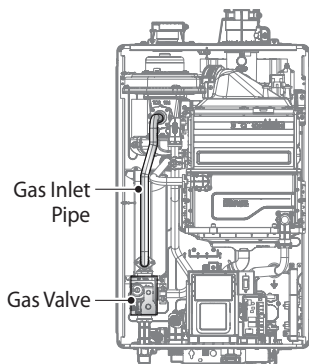

Figure 2. NPE-A2/S2 Series Internal Components

3. Once the front cover is removed, place it in a safe location to prevent accidental damage. With the internal components exposed, locate the gas inlet pipe and the Gas Valve near the left side of the unit which are highlighted in Figure 2.
4. Use a Phillips screwdriver to remove the two screws at Location A - the connection below the Gas Valve where it connects to the pipe. See Figure 3 for reference. Once the screws are removed, carefully separate the pipe from the Gas Valve.
5. Once the gas inlet pipe is detached from the Gas Valve, find Location B - the connection above the Gas Valve where it is attached to the Fan Motor Assembly. Carefully remove the four screws by hand using a Phillips screwdriver and pull the Gas Valve away from the Fan Assembly to access the Gas Orifice.

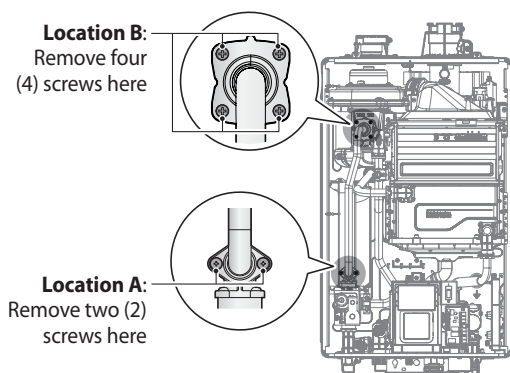

Figure 3. Detaching Gas Valve from Gas Inlet Pipe and Fan Motor Assembly

6. Once the Gas Orifice is exposed, remove the two screws that hold the part in place. Remove the Gas Orifice from its housing and prepare the new Gas Orifice for the Propane or High Altitude conversion for installation.

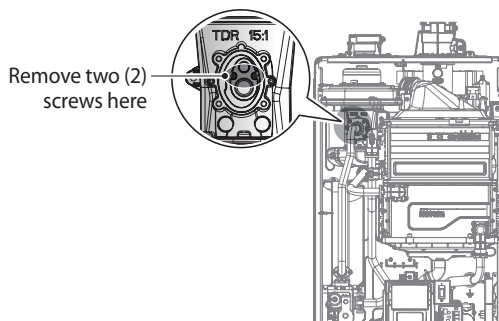

Figure 4. Access to Gas Orifice in Fan Assembly

## **⚠ DANGER**

### **Fire and Explosion Hazard**

To prevent serious injury, death, or property damage:

- DO NOT adjust or attempt to measure gas valve outlet pressure. The gas valve is factory-set for the correct outlet pressure. This setting is suitable for natural gas and propane, requiring no field adjustment.
- Attempting to alter or measure the gas valve outlet pressure could result in damage to the valve, causing potential severe personal injury, death or substantial property damage. Navien water heaters are shipped ready to fire natural gas ONLY.

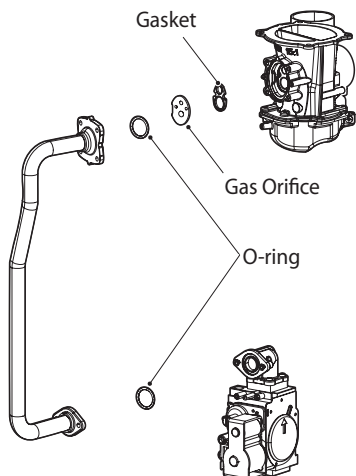
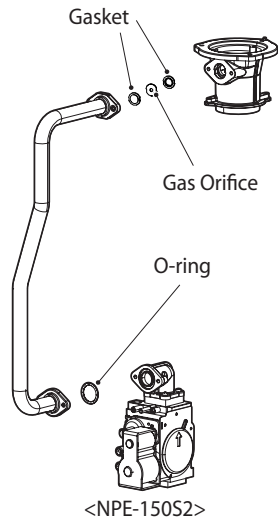

<NPE-180A2/S2, 210A2/S2, 240A2/S2>  
Figure 5. Exploded view of Gas assembly

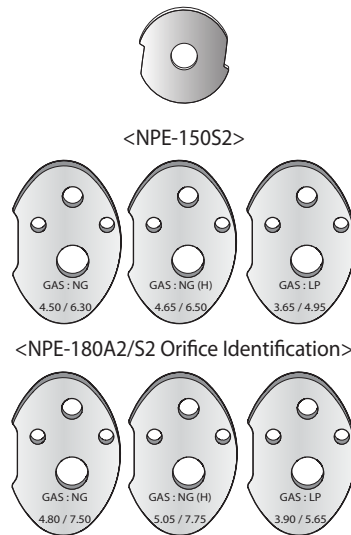

<NPE-150S2>  
<NPE-180A2/S2 Orifice Identification>  
<NPE-210A2/S2, 240A2/S2 Orifice Identification>

Figure 6. Orifice identification

- Remove the Gas Orifice, ensure that the gasket is properly seated inside the port, and then install the new Gas Orifice. Ensure that the Orifice is properly seated on the gasket inside the port before proceeding to the next step.

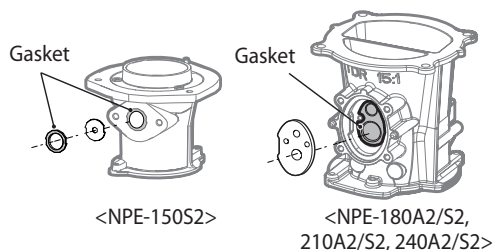

- Replace the gas inlet pipe to its original position and use all screws to secure all connections.

**Note**

Do not overtighten as this may damage or crack the components.

**⚠ DANGER**

**Fire and Explosion Hazard**

To prevent serious injury, death, or property damage:

- ALWAYS inspect the O-ring between the gas valve and gas valve inlet adapter whenever they are disassembled (see Figure 5).
- The O-ring must be in good condition and must be installed. Replace O-ring if needed.

## **⚠ DANGER**

### **Fire and Explosion Hazard**

To prevent serious injury, death, or property damage:

- Ensure that the gasket is properly seated inside the port before installing the Gas Orifice into its housing.

## **⚠ WARNING**

### **Electric Shock Hazard**

ALWAYS turn off power to water heater before accessing the DIP switches to prevent serious injury or death.

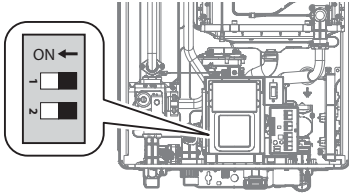

Switch	Function	Setting	
1	Gas Type	Natural Gas	OFF
		Propane Gas	ON

9. When changing the gas type, configure the DIP switch setting as shown below.

#### **Note**

If you do not convert the gas type, skip step 9 and follow the instructions in step 10.

- a. Set front panel DIP switch 1 to change the gas type.
  - Natural Gas: Set DIP switch 1 to OFF.
  - Propane Gas: Set DIP switch 1 to ON.
- b. Turn on the power to the water heater. Then, error 788 will occur.
- c. In error display mode, press the Back button (↩) to execute the Gas Type Check menu under Start-Up Wizard.
- d. Set the Gas Type Check option.
  - Natural Gas: The error is cleared and the water heater starts to operate normally.
  - Propane Gas: When the gas type is identified as changed in the Gas Conversion Kit Required option, the error is cleared and the water heater starts to operate normally.

10. Set the panel setting corresponding to the installation altitude.
  - a. Press and hold the Menu button (M) and the Back button (↩) simultaneously for 3 seconds on the front panel to access the Service/Installer menu.
  - b. Select **1. Installer Menu > 2. Parameter Settings > 14. Altitude Setting** by pressing the OK button (OK) and set up the altitude.

Function	Menu	Description
Altitude Setting	1. Installer Menu	1. 0-2,000 ft
	2. Parameter Settings	2. 2,000-5,400 ft
	1.2.14. Altitude Setting	3. 5,400-7,700 ft
		4. 7,700-10,100 ft

#### **Note**

When prompted, please confirm the installation elevation by using the provided QR code. You can also access the following website (<https://www.navieninc.com/elevation>) and enter the proper zip/postal code.

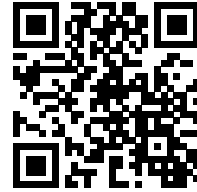

11. Turn on the gas and water supply to the water heater.

## **⚠ DANGER**

### **Carbon Monoxide Hazard**

To prevent serious injury, death, or property damage:

- ALWAYS check the Altitude Setting is appropriate for the installation location altitude.
- If the Altitude setting is not appropriate, then the water heater could cause carbon monoxide poisoning.

**Note**

- This unit may be installed at elevations up to 10,100 ft (3,078 m) for use with natural gas and propane. To use the unit at a specific altitude, the altitude setting should be configured as described above.
- High Altitude: Above 2,000 ft (610 m), the unit will de-rate by 3% for LNG Models or 4.5% for LPG models for each 1,000 ft (305 m) of altitude gain.
- For Natural gas, if you install the unit at above 5,400 ft (1,646 m), it is required to change the Gas Orifice for high altitude. Be careful not to confuse it with the Gas Orifice for propane gas.
- Note that the Gas Orifice from the PROPANE GAS AND HIGH ALTITUDE KIT covers the water heater's installation at an altitude of 0 to 10,100 ft.

**⚠ DANGER**

To prevent serious injury, death, or property damage:

- ALWAYS check the panel DIP switch 1 is set according to the supply gas type.
- For natural gas, only install the gas orifice for high altitude when the water heater is installed at above 5,400 ft.
- Be careful to install the Natural Gas High Altitude Conversion Kit and not to confuse it with the Propane Gas & High Altitude Conversion Kit.
- Failure to properly install the High Altitude Conversion Kit or to not use the appropriate Altitude Settings could cause carbon monoxide poisoning, resulting in serious injury or death.

12. Measure and adjust the gas/air ratio.
  - Option 1. Using Combustion Analyzer (recommended)
    - a. Open the cover of the emissions monitoring port as shown in Figure 7.
    - b. Insert the analyzer into the port.

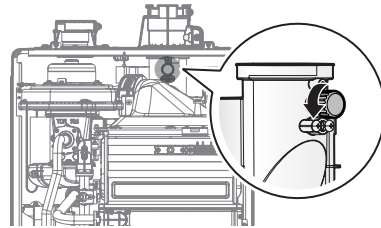

Figure 7. Insert the Analyzer

Water Heater	Altitude	Fuel	High Fire	Low Fire
			%CO <sub>2</sub>	%CO <sub>2</sub>
NPE-150S2	0 - 5,399 ft	Natural Gas	8.9	9.2
	5,400 - 10,100 ft			
NPE-180A2 NPE-180S2	0 - 10,100 ft	Propane Gas	10.7	11.0
	0 - 5,399 ft			
NPE-210A2 NPE-210S2	0 - 5,399 ft	Natural Gas	8.8	8.9
	5,400 - 10,100 ft			
NPE-240A2 NPE-240S2	0 - 10,100 ft	Propane Gas	10.5	10.7
	0 - 5,399 ft			

Table 2. CO<sub>2</sub> and CO value  
(CO<sub>2</sub> values must be within 0.5% of the values listed.)

- c. Fully open several hot water fixtures and set the water heater to operate at 1-stage MIN mode (refer to "Setting the Operation Mode" on page 115). Measure the CO<sub>2</sub> value at low fire.

If the CO<sub>2</sub> value is not within 0.5% of the value listed in Table 2, the gas valve set screw will need to be adjusted.

If adjustment is necessary, locate the set screw as shown in Figure 8. Using a 5/32 in. or 4 mm Allen wrench, turn the set screw no more than 1/4 turn clockwise to raise or counterclockwise to lower the CO<sub>2</sub> value.

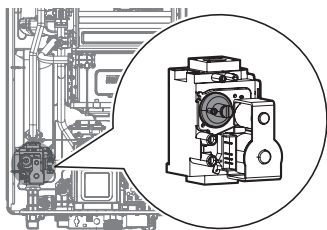

Figure 8. Set Screw Location

**Note**

The set screw is located behind the screw-on cover. This must be removed first.

- d. Fully open several hot water fixtures and set the water heater to operate at 2-stage MAX mode (refer to "Setting the Operation Mode" on page 115). Measure the CO<sub>2</sub> value at high fire.

If the CO<sub>2</sub> values do not match Table 2 at high fire, do not adjust the gas valve. Check for the proper Gas Orifice.

**⚠ DANGER**

Improper gas valve settings can cause fire or explosion and result in death, serious injury or property damage.

Option 2. Using Digital Manometer

- a. Open the offset pressure port by loosening the screw two turns as shown in Figure 9.

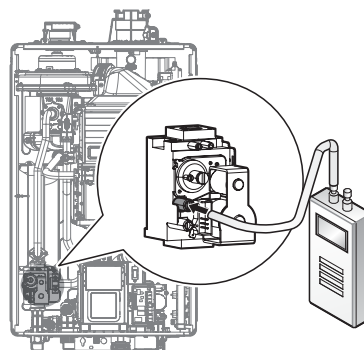

Figure 9. Connect Digital Pressure Monometer

- b. Connect a manometer to the offset pressure port. For dual port manometers, use the positive pressure side.

Model	Altitude	Kit Part No.	Gas Type	Offset
NPE-150S2	0 - 5,399 ft	NAC-N150	Natural Gas	-0.04 in. ± 0.01 in.
	5,400 - 10,100 ft	NAC-NH150		
	0 - 10,100 ft	NAC-L150	Propane Gas	-0.03 in. ± 0.01 in.
NPE-180A2 NPE-180S2	0 - 5,399 ft	NAC-N180	Natural Gas	-0.03 in. ± 0.01 in.
	5,400 - 10,100 ft	NAC-NH180		
	0 - 10,100 ft	NAC-L180	Propane Gas	-0.02 in. ± 0.01 in.
NPE-210A2 NPE-210S2	0 - 5,399 ft	NAC-N210	Natural Gas	-0.03 in. ± 0.01 in.
	5,400 - 10,100 ft	NAC-NH210		
	0 - 10,100 ft	NAC-L210	Propane Gas	-0.02 in. ± 0.01 in.
NPE-240A2 NPE-240S2	0 - 5,399 ft	NAC-N240	Natural Gas	-0.03 in. ± 0.01 in.
	5,400 - 10,100 ft	NAC-NH240		
	0 - 10,100 ft	NAC-L240	Propane Gas	-0.02 in. ± 0.01 in.

Table 3. Offset value for low fire

- c. Fully open a hot water fixture and set the water heater to operate at 1-stage MIN mode (refer to “Setting the Operation Mode” on page 115). Measure the offset value at low fire and compare it to the values in Table 3. If the offset value is out of range, the gas valve set screw will need to be adjusted. If adjustment is necessary, locate the set screw as shown in Figure 10. Using a 5/32 in. or 4 mm Allen wrench, turn the set screw no more than 1/4 turn clockwise to raise or counterclockwise to lower the offset value.

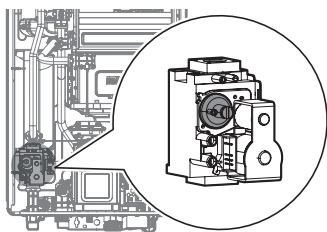

Figure 10. Set Screw Location

**Note** The set screw is located behind the screw-on cover. This must be removed first.

- d. At high fire, do not check the offset value and never adjust the gas valve.

## **⚠ DANGER**

Improper gas valve settings can cause fire or explosion and result in death, serious injury or property damage.

13. Once the CO<sub>2</sub> or offset values have been confirmed, apply the included conversion stickers to show that the appliance has been converted to natural gas. Place this labels adjacent to the rating plate as shown in Figure 11.

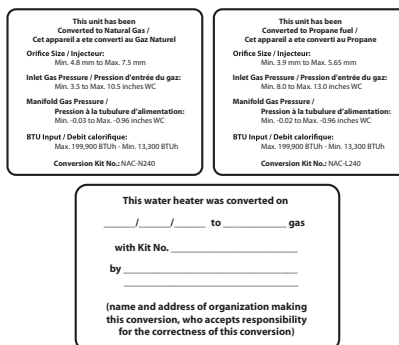

Figure 11. Proper Placement of Gas Conversion Labels

**Note** Manifold Gas Pressure ratings can change due to updated orifice sizes. Please confirm new manifold pressures approved by CSA before production of gas conversion labels.

## Setting the Operation Mode

- Press and hold the Menu button (M) and the Back button (←) simultaneously for 3 seconds and then select **4. Special Operations**.
- Press the Up button (▲) or the Down button (▼) to switch between the special operation modes. Press the OK button (OK) to select a parameter or to run a special operation mode.

Item	Description
1. Normal	Set the water heater to run in the normal mode.
2. 1 <sup>st</sup> MIN	Set the water heater to run in the 1-stage minimum operation mode.
3. 1 <sup>st</sup> MAX	Set the water heater to run in the 1-stage maximum operation mode.
4. 2 <sup>nd</sup> MIN	Set the water heater to run in the 2-stage minimum operation mode.
5. 2 <sup>nd</sup> MAX	Set the water heater to run in the 2-stage maximum operation mode.

- Press the Back button (←) to return to the previous screen or menu.

# 8.2 Flushing the Heat Exchanger

To flush the Heat Exchanger: NPE-A2/S2 models

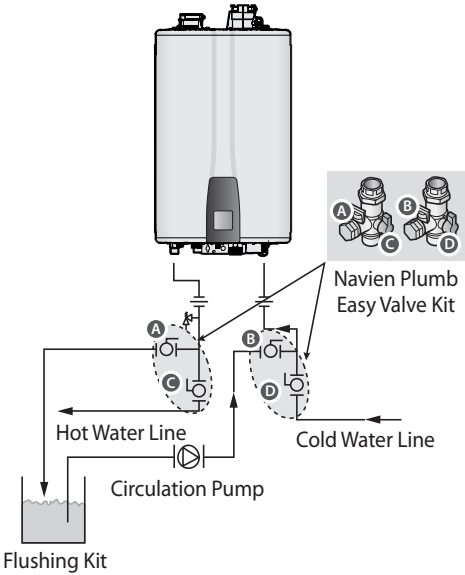

**Note** For more information about flushing the NPE-S2's Heat Exchanger, refer to "4.3 Flushing the Heat Exchanger" on page 12 of the User's Information Manual.

## 8.3 Technical Data

### Pressure Drop Curve

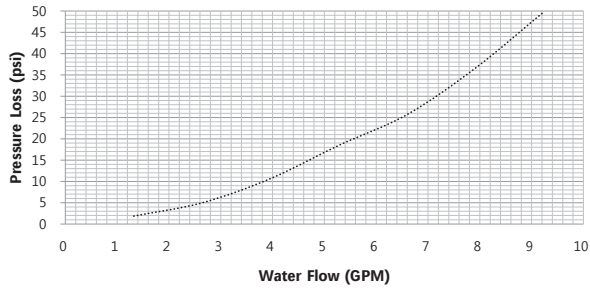

**[NPE-240A2/ 240S2]**

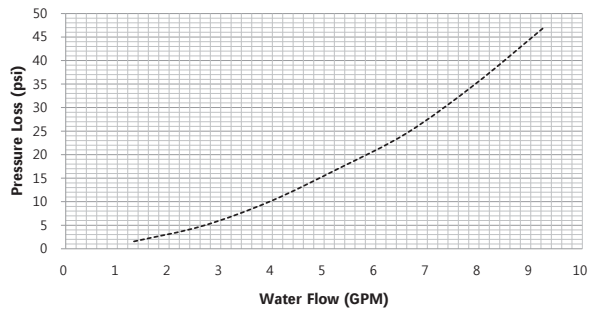

**[NPE-210A2/ 210S2]**

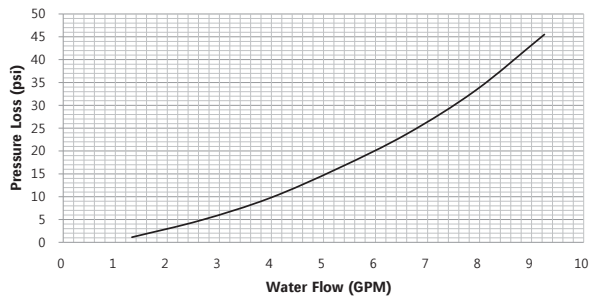

**[NPE-180A2/ 180S2]**

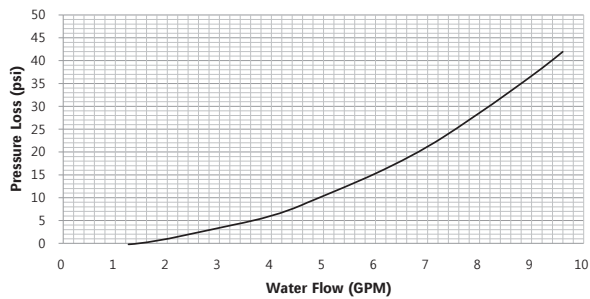

**[NPE-150S2]**

# Outlet Flow Data

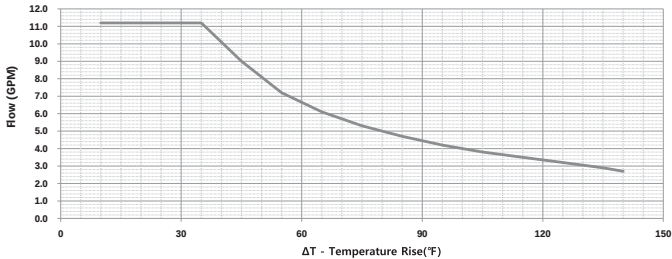

[NPE-240A2]

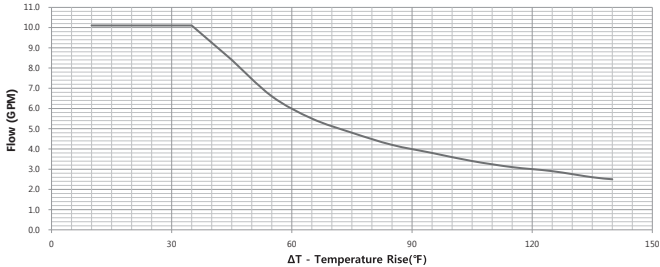

[NPE-210A2]

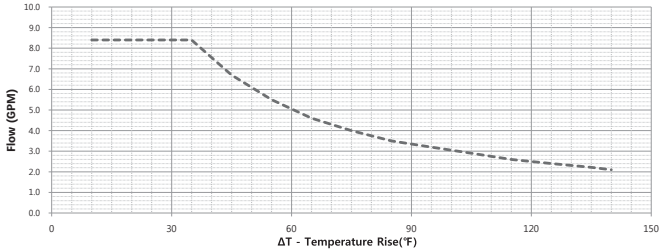

[NPE-180A2]

**Note** At altitudes above 2,000 ft (610 m), the outlet flow will be reduced by 3% (NG Model) or 4.5% (LP Model) for each 1,000 ft (305 m) of altitude gain.

## Outlet Flow Data

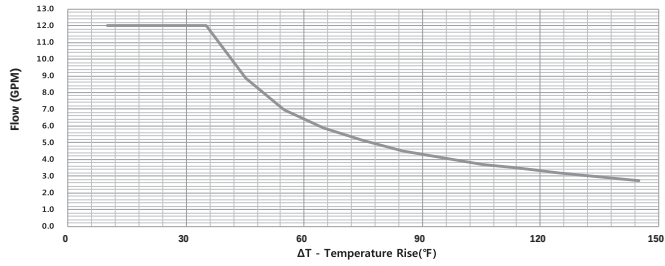

[NPE-240S2]

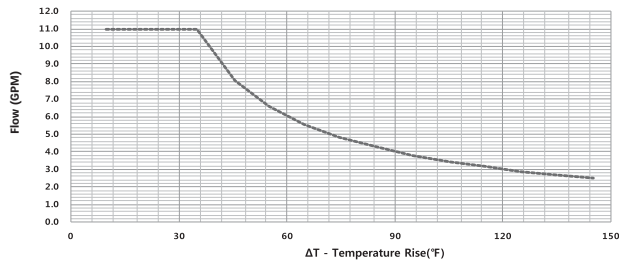

[NPE-210S2]

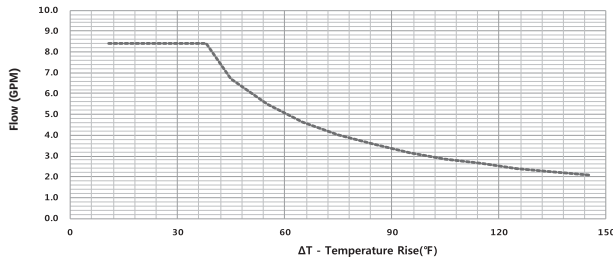

[NPE-180S2]

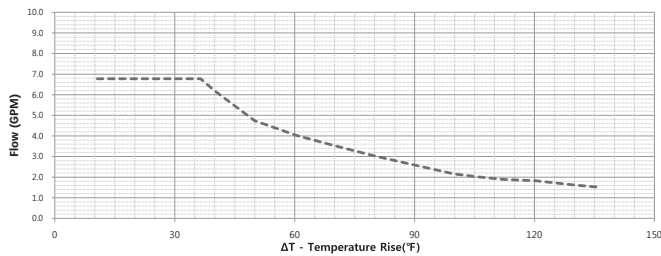

[NPE-150S2]

**Note**

At altitudes above 2,000 ft (610 m), the outlet flow will be reduced by 3% (NG Model) or 4.5% (LP Model) for each 1,000 ft (305 m) of altitude gain.

## 8.4 Wiring Diagram

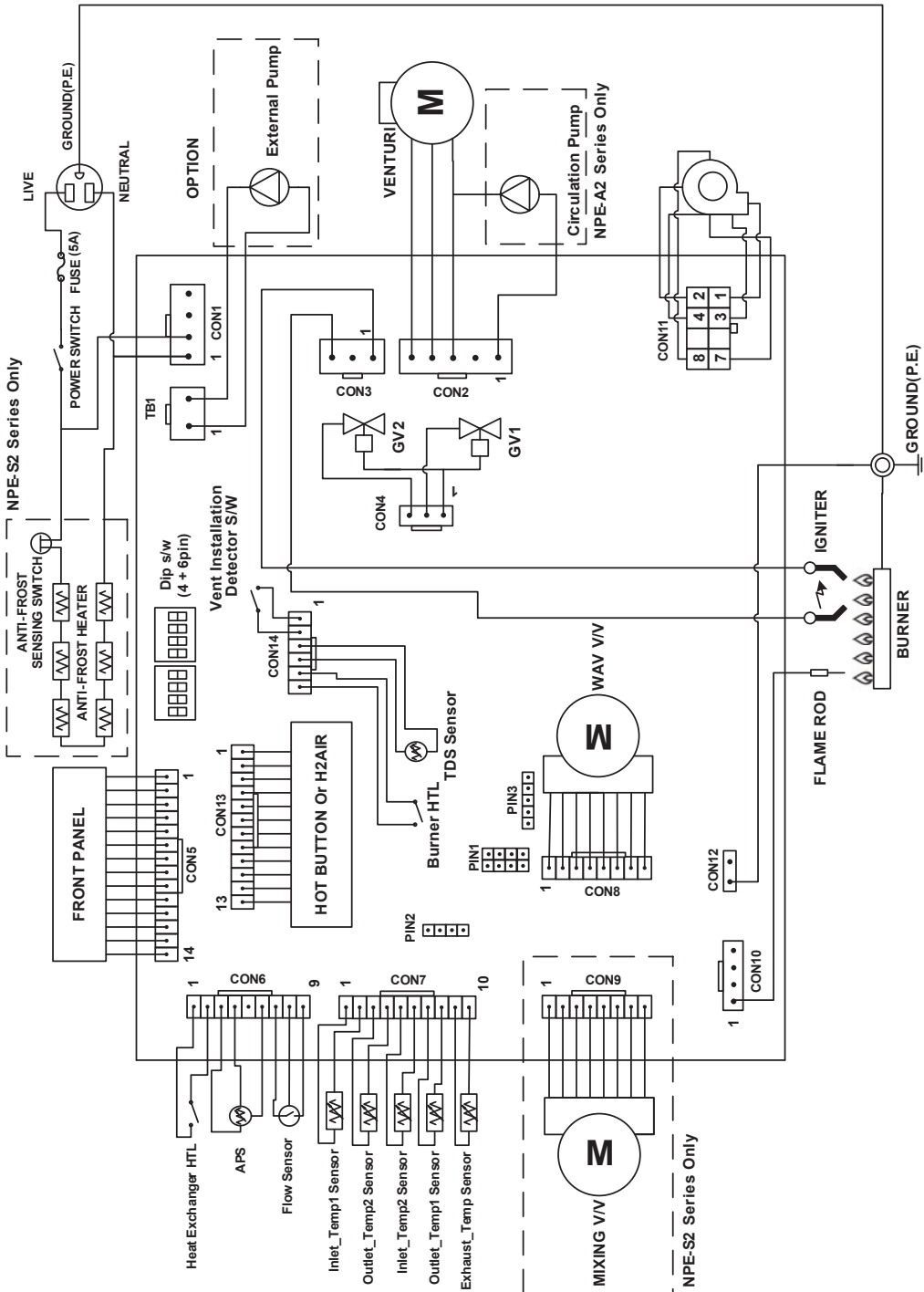

[NPE-150S2, 180A2/S2, 210A2/S2, 240A2/S2]

## 8.5 Ladder Diagram

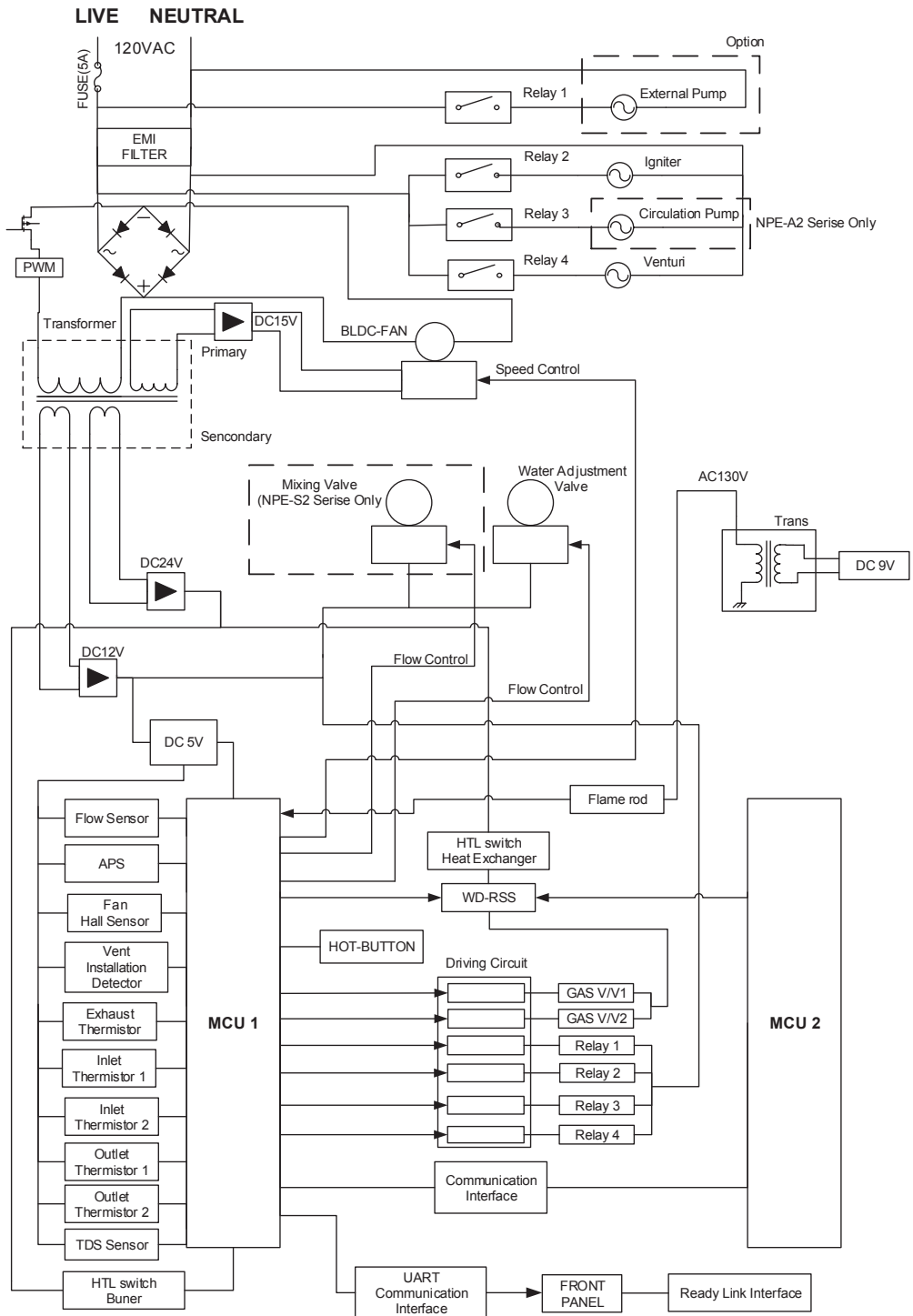

**[NPE-150S2, 180A2/S2, 210A2/S2, 240A2/S2]**

# 8.6 Component Assembly Diagrams and Parts Lists

## 8.6.1 Case Assembly

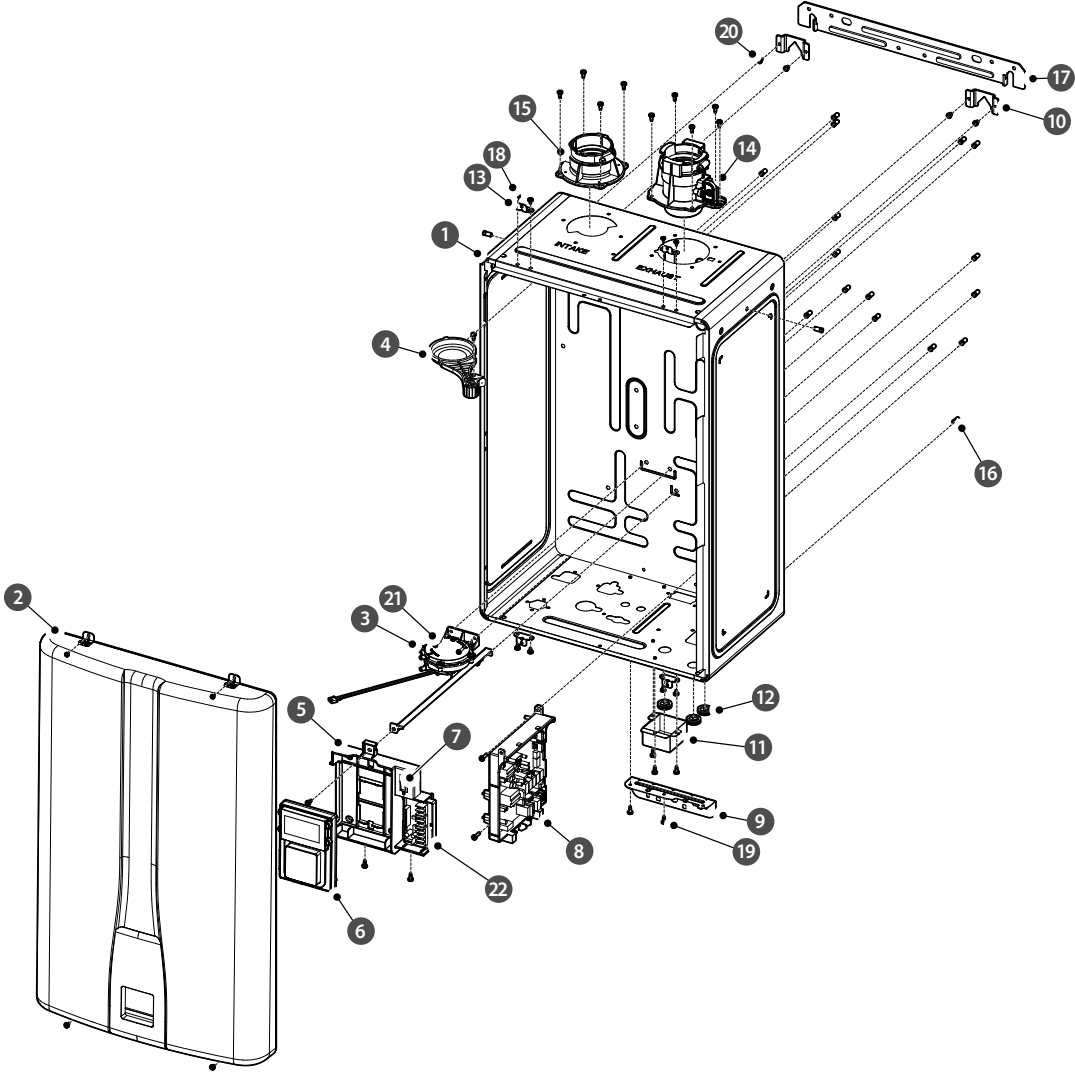

#	Description	Service Code	Part #	Remark
1	Case	-	20049732*	NPE-180A2/210A2/240A2
		-	20049515*	NPE-150S2/180S2/210S2/240S2
2	Cover	30026143A	30024855*	
3	Air Pressure Sensor	30021100B	30021100*	
4	Intake Air Filter	30016248B	30016248*	
5	Panel Bracket	-	20049470*	
6	Front Panel	30027275A	30024955*	
7	Power Switch	30009482A	30009482*	
8	PCB	30027274A	30024835*	NPE-180A2/210A2/240A2
			30024837*	NPE-150S2/180S2/210S2/240S2
9	Case Bracket (Lower)	-	20048214*	
10	Case Bracket (Upper)	-	20049507*	
11	Junction Box	-	20061726*	
12	Rubber Ring	-	20025127*	
13	Case Bracket (Lock)	-	20049636*	
14	Exhaust Duct Assembly	30024848B	30024848*	
15	Intake Air Duct Assembly	30008662B	30008662*	
16	Pop nut	-	20047199*	
17	Wall Bracket	-	20007610*	
18	Screw, STS410, 4x6	-	20050522*	
19	Screw, STS410, 4x10	20049000A	20049000*	
20	Screw, STS430, M4x6	-	20050523*	
21	Screw, S18A, M4x14	-	20041463*	
22	Hotbutton	30025294A	30025294*	

8.6.2 Burner Assembly (NPE-180A2/ 210A2/ 240A2)

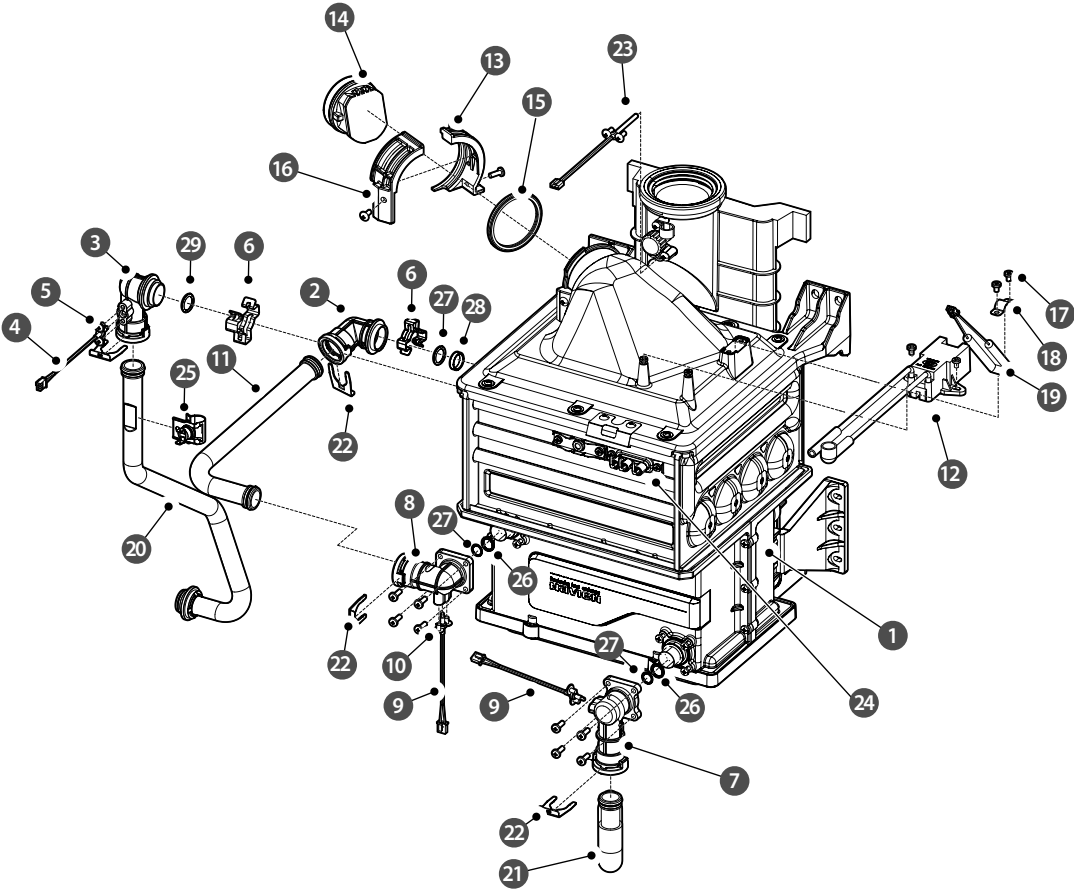

#	Description	Service Code	Part #	Remark
1	Heat Exchanger Assembly	30026111A	30024850*	NPE-210A2/240A2
		30026110A	30025104*	NPE-180A2
2	SC-Ex Inlet Adaptor	-	20049491*	
3	SC-Ex Outlet Adaptor	-	30024763*	
4	Thermistor	30008366A	30008366*	
5	Screw, S10A, 4x6	20017962A	20017962*	
6	Fastener	20007853A	20007853*	
7	Flow Sensor Assembly	30024866A	30024866*	
8	Latent-Ex Outlet Adaptor	-	30024764*	
9	Thermistor	30008366A	30008366*	
10	Screw, S10A, 4x6	20017962A	20017962*	
11	H-Ex Middle Pipe	-	30024769*	NPE-210A2/240A2
		-	30024768*	NPE-180A2
12	Ignition Transformer	30026063A	30026063*	
13	Fan Bracket (R)	-	20022096*	
14	Fan Damper	30008825A	30008825*	
15	Fan Packing	-	20022744*	
16	Fan Bracket (F)	20022095A	20022095*	
17	Screw, S18A, M4x6	-	20038859*	
18	Burner Fuse Bracket	-	20050642*	
19	Burner Fuse	30025036A	30025036*	
20	Hot Water Outlet Pipe	30024771A	30024771*	NPE-210A2/240A2
		30024770A	30024770*	NPE-180A2
21	Cold Inlet Pipe	30024767A	30024767*	NPE-210A2/240A2
		30024766A	30024766*	NPE-180A2
22	Pipe Clip	20045992A	20045992*	
23	Thermistor (Exhaust)	30009478A	30009478*	
24	Igniter	30028036A	30025442*	
25	High Limit Switch	30023954A	30023954*	
26	Packing (Φ26.5x2.4t)	-	20006868*	
27	O-ring (Φ17.5x2.7t)	20006949A	20006949*	
28	Backup Ring	-	20018744*	
29	O-ring (Φ21.7xΦ3.5)	-	20033699*	

### 8.6.3 Burner Assembly (NPE-150S2/180S2/ 210S2/ 240S2)

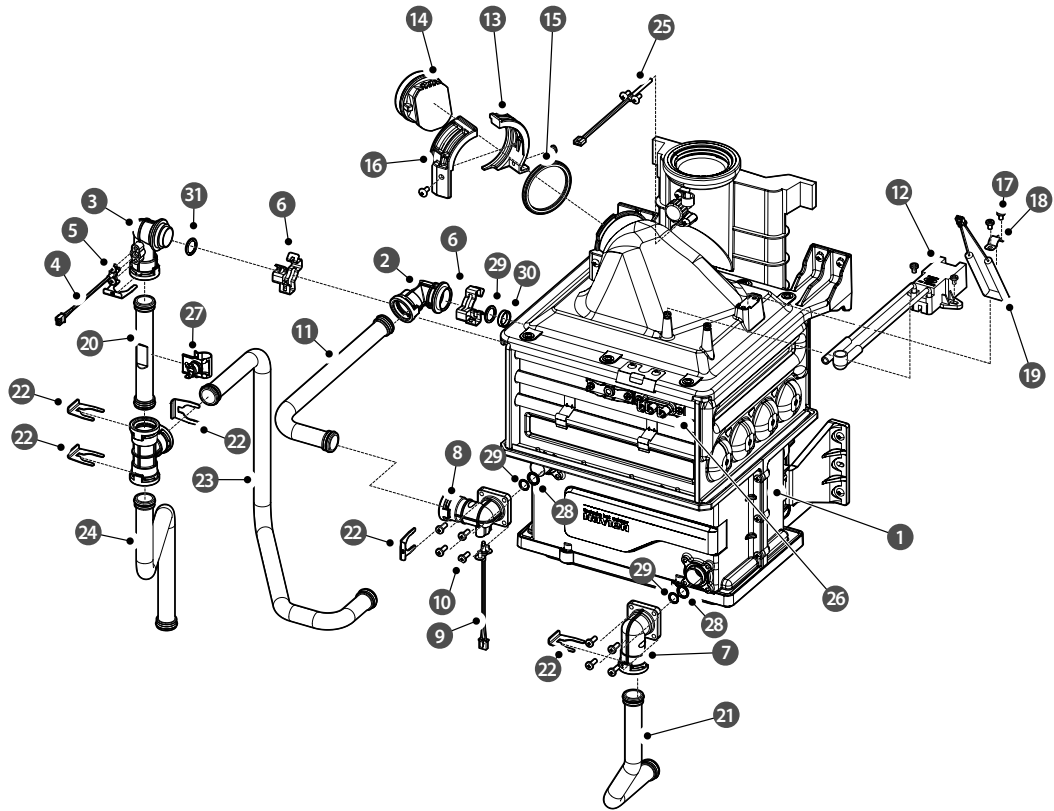

#	Description	Service Code	Part #	Remark
1	Heat Exchanger Assembly	30026111B	30025252*	NPE-210S2/240S2
		30026110B	30025110*	NPE-180S2
		30026109B	30025477*	NPE-150S2
2	SC-Ex Inlet Adaptor	-	20049491*	
3	SC-Ex Outlet Adaptor	-	30024763*	
4	Thermistor	30008366A	30008366*	
5	Screw, S10A, 4x6	20017962A	20017962*	
6	Fastener	20007853A	20007853*	
7	Latent-Ex Inlet Adaptor	-	20049517*	
8	Latent-Ex Outlet Adaptor	-	30024764*	
9	Thermistor	30008366A	30008366*	
10	Screw, S10A, 4x6	20017962A	20017962*	

#	Description	Service Code	Part #	Remark
11	H-Ex Middle Pipe	-	30024769*	
		-	30024768*	
		-	30025435*	
12	Ignition Transformer	30026063A	30026063*	
13	Fan Bracket (R)	-	20022096*	
14	Fan Damper	30008825A	30008825*	
15	Fan Packing	-	20022744*	
16	Fan Bracket (F)	20022095A	20022095*	
17	Screw, S18A, M4×6	-	20038859*	
18	Burner Fuse Bracket	-	20050642*	
19	Burner Fuse	30025036A	30025036*	
20	Heat Exchanger Outlet Pipe	30024780A	30024780*	NPE-180S2/210S2/240S2
		30024779A	30024779*	NPE-150S2
21	Cold Inlet Pipe	30024778A	30024778*	NPE-210S2/240S2
		30024777A	30024777*	NPE-180S2
		30024776A	30024776*	NPE-150S2
22	Clip	20045992A	20045992*	
23	Mixing Pipe	30024784A	30024784*	NPE-210S2/240S2
		30024783A	30024783*	NPE-180S2
		30024782A	30024782*	NPE-150S2
24	Hot Water Outlet Pipe	30024787A	30024787*	NPE-210S2/240S2
		30024786A	30024786*	NPE-180S2
		30024785A	30024785*	NPE-150S2
25	Thermistor (Exhaust)	30028036A	30025442*	NPE-180S2/ 210S2/ 240S2
		30028039A	30025472*	NPE-150S2
26	Igniter	30025442A	30025442*	
27	High Limit Switch	30023954A	30023954*	
28	Packing (Φ26.5x2.4t)	-	20006868*	
29	O-ring (Φ17.5x2.7t)	20006949A	20006949*	
30	Backup Ring	-	20018744*	
31	O-ring (Φ21.7xΦ3.5)	-	20033699*	

### 8.6.4 Waterway Assembly (NPE-180A2/210A2/240A2)

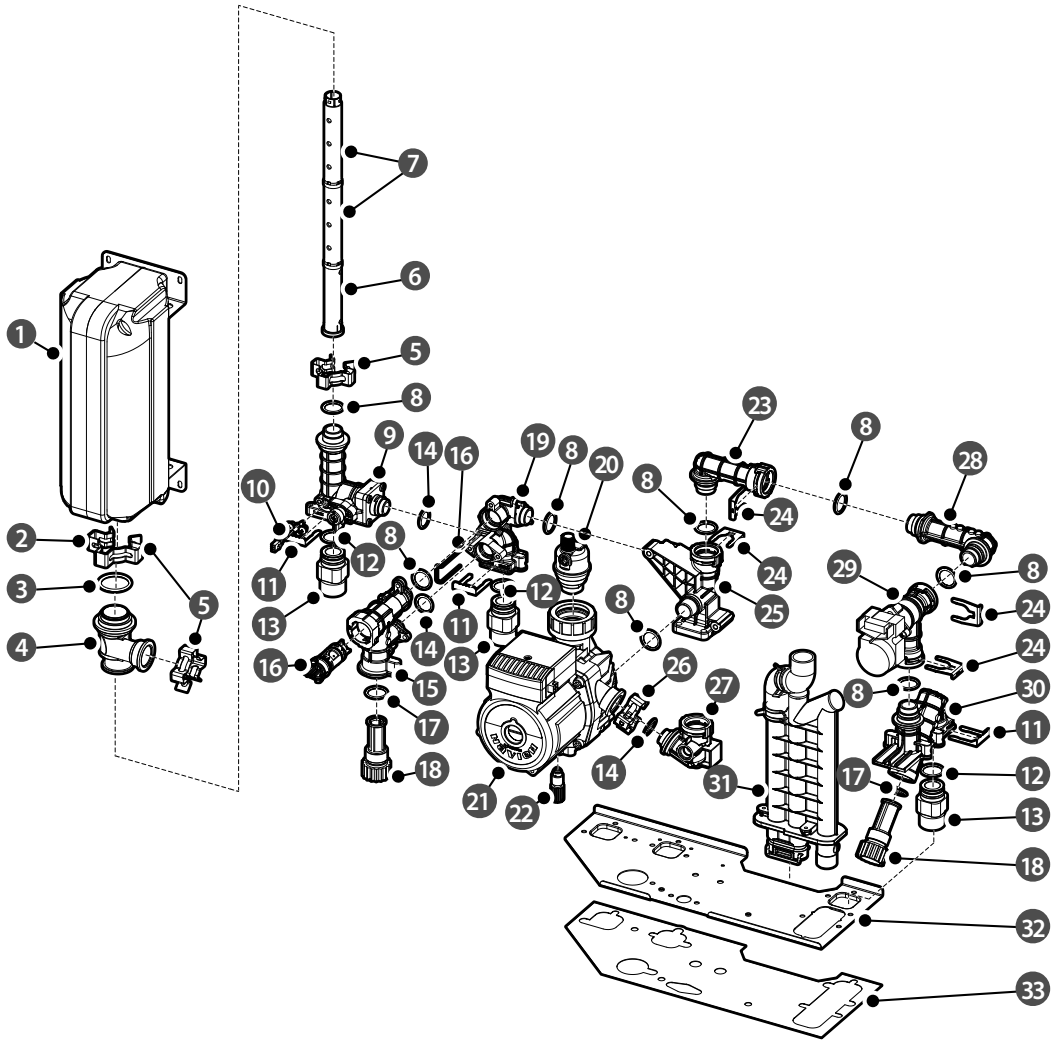

#	Description	Service Code	Part #	Remark
1	Buffer Tank	30016125A	30023708*	
2	Fastener	20017724A	20017724*	
3	O-RING (P29)	20017923A	20017923*	
4	Buffer Tank Adapter	20035697A	20035697*	
5	Fastener	-	20017726*	
6	Buffer Tank Pipe A	-	20017759*	
7	Buffer Tank Pipe B	-	20017760*	
8	O-RING (P18)	20006947A	20006947*	

#	Description	Service Code	Part #	Remark
9	Hot Water Outlet Adapter	-	30008338*	
10	Thermistor	30008366A	30008366*	
11	Clip	20007733B	20007733*	
12	O-RING (P20)	20017212A	20017212*	
13	Pipe Adapter	20024496A	20024496*	
14	O-RING (P16)	20017210A	20017210*	
15	Check Valve Adapter	20048412A	20048412*	
16	Check Valve	30024442A	30008360*	
17	O-RING (P19)	20017211A	20017211*	
18	Water Filter	30008171A	30008171*	
19	Return Connect Adapter	20048405A	20048405*	
20	Pump Air Separator	30014451A	30013056*	
21	Circulation Pump	30010780C	30008355*	
22	Drain Plug	30008630D	30008630*	
23	Pump Connect Adapter	20048418A	20048418*	
24	Clip	20045992A	20045992*	
25	Pump Inlet Adapter	20048414A	20048414*	
26	Fastener	20007859A	20007859*	
27	Pump Outlet Adapter	20048419A	20048419*	
28	WAV Outlet Adapter	20048415A	20048415*	
29	Water Adjust Valve	30024183A	30024183*	
30	Cold Water Adapter	20048454A	20048454*	
31	Syphon	30024921A	30024921*	
32	Bracket	-	20048396*	
33	Bracket Packing	-	20048400*	

8.6.5 Waterway Assembly (NPE-150S2/180S2/210S2/240S2)

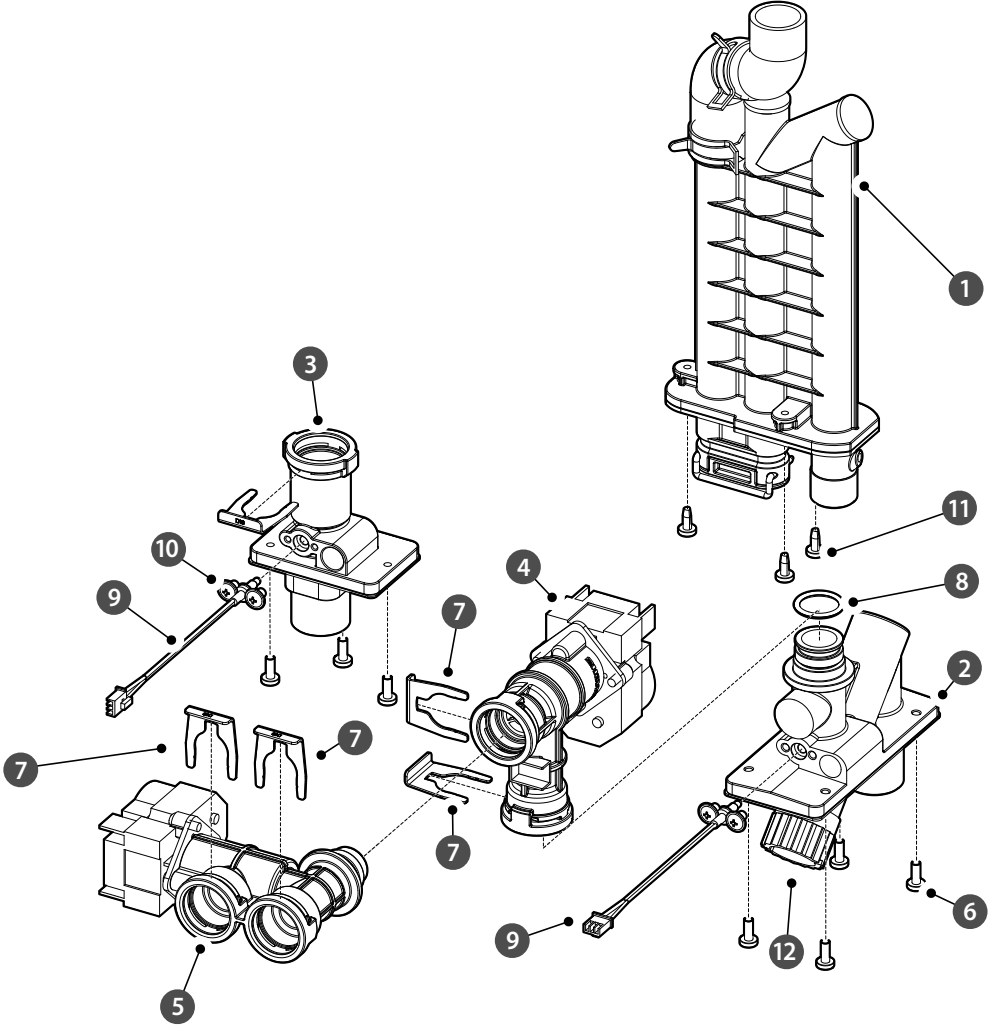

#	Description	Service Code	Part #	Remark
1	Syphon	30024921A	30024921*	
2	Cold Water Inlet Adapter	30024923A	30024923*	
3	Hot Water Outlet Adapter	-	30024924*	
4	Water Adjust Valve (Built in Flow Sensor)	30022123A	30022123*	
5	Mixing Valve	30022124A	30022124*	
6	Screw, STS430, M4×10	-	20038758*	
7	Clip	20045992A	20045992*	
8	O-RING (P18)	20006947A	20006947*	
9	Thermistor	30008366A	30008366*	
10	Screw, S10A, M4×6	-	20027618*	
11	Screw, STS410, 4×10	20049000A	20049000*	
12	Water Filter	30008171A	30008171*	

### 8.6.6 Fan (Gas) Assembly

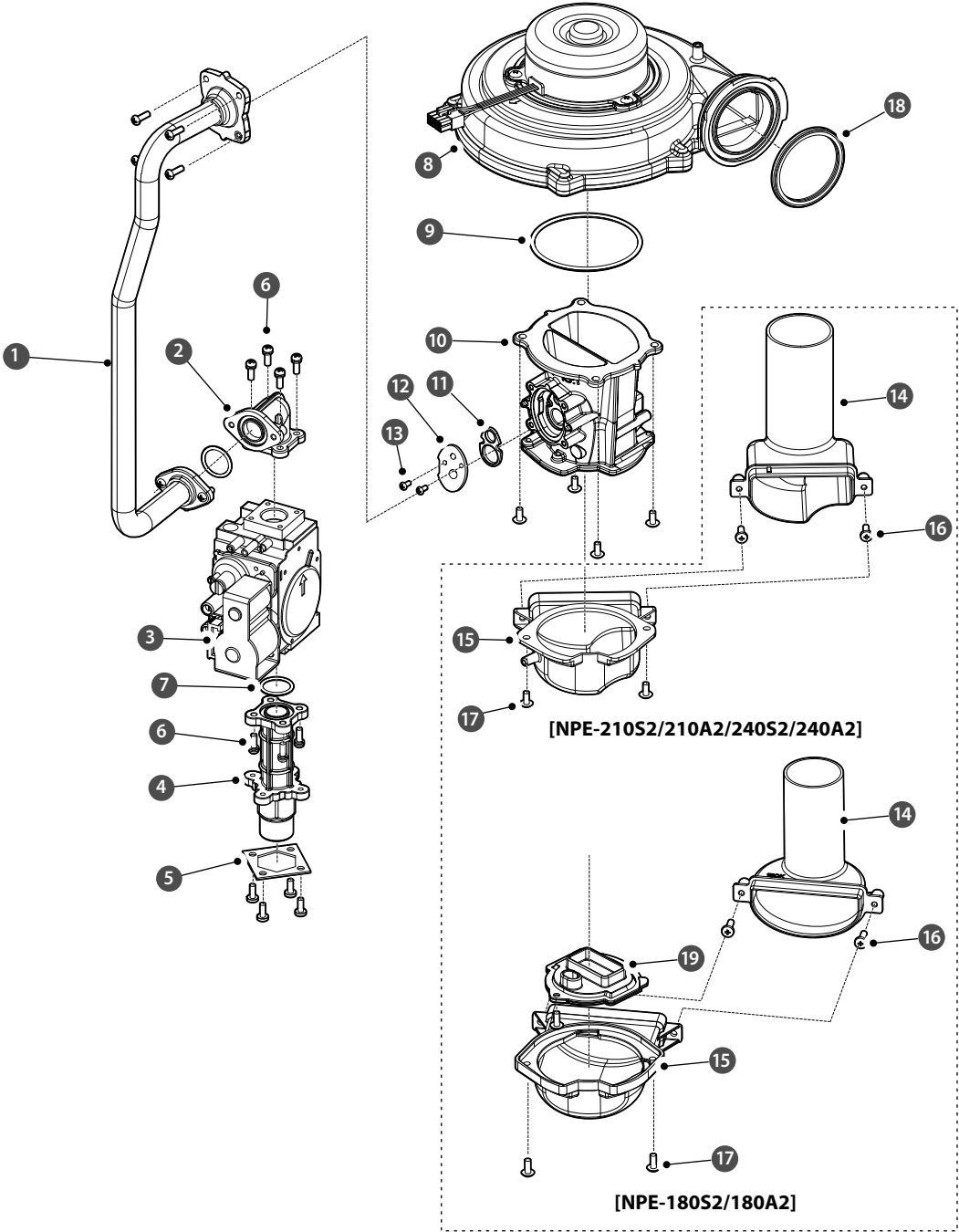

[NPE-180S2/180A2/210S2/210A2/240S2/240A2]

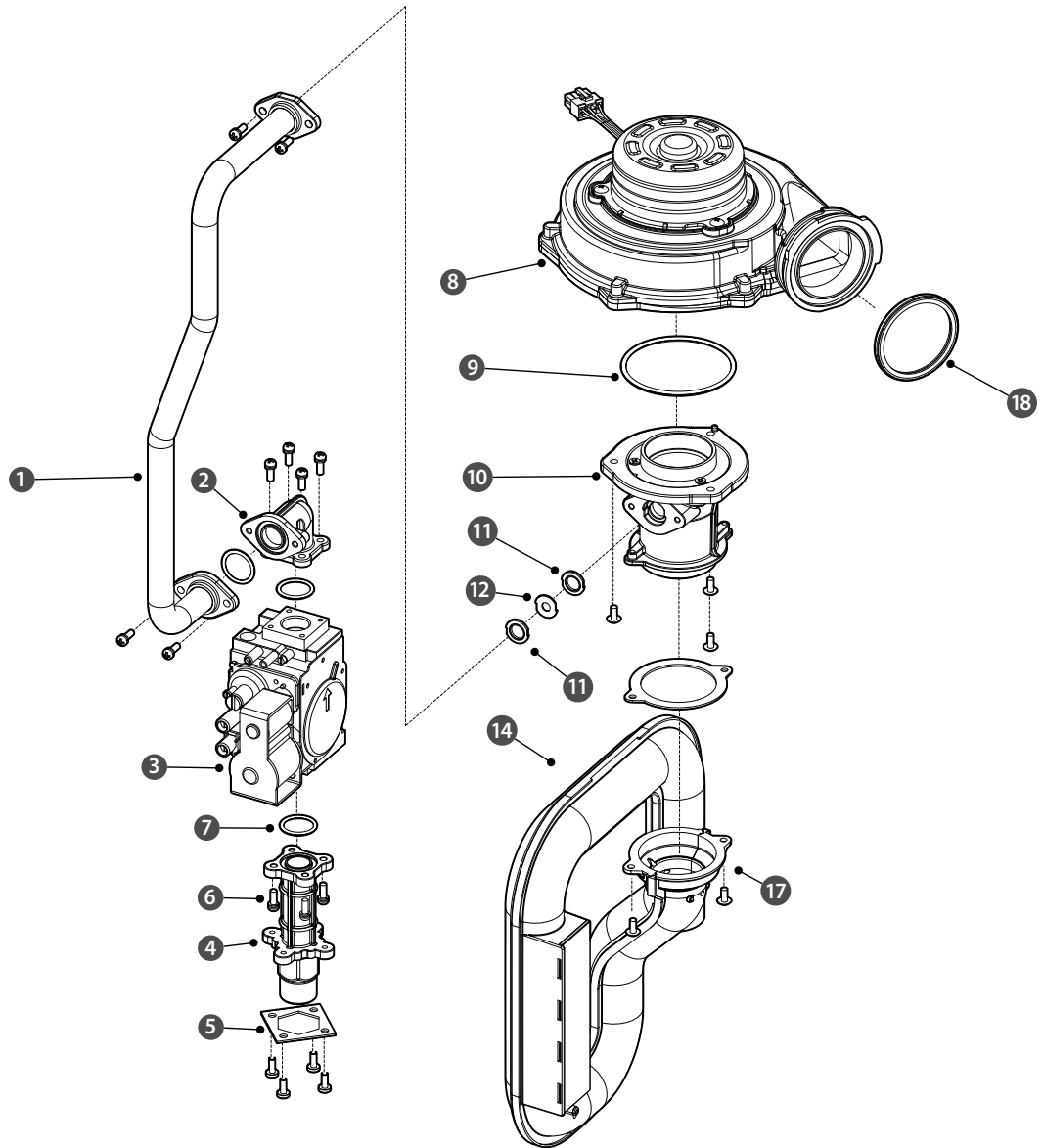

[NPE-150S2]

#	Description	Service Code	Part #	Remark
1	Gas Pipe	30024773A	30024773*	NPE-210S2/240S2/210A2/240A2
		30024772A	30024772*	NPE-180S2/180A2
		30025069A	30025069*	NPE-150S2
2	Gas Connector	20018430A	20018430*	
3	Gas Valve	30011586B	30011586*	
4	Gas Inlet Adapter	20023809A	20023809*	
5	Gas Inlet Adapter Packing	-	20023581*	
6	Screw, S10A, M4x12	20006390A	20006390*	
7	O-Ring (P20)	20006934A	20006934*	
8	Fan Assembly	30015421A	30015421*	NPE-150S2
		30025295A	30025295*	NPE-180S2/180A2/210S2/210A2/ 240S2/240A2
9	O-Ring (G70)	20007001A	20007001*	NPE-150S2
	O-Ring (G75)	20018079A	20018079*	NPE-180S2/180A2/210S2/210A2/ 240S2/240A2
10	Single Venturi	30014688A	30014688*	NPE-150S2
	Dual Venturi	30027149A	30024967*	NPE-180S2/180A2
			30025251*	NPE-210S2/240S2/210A2/240A2
11	Venturi Packing	20022660A	20022660*	
12	Gas Orifice	20049501B	20049501*	NPE-210S2/240S2/210A2/240A2 (NG)
		20050546A	20050546*	NPE-210S2/240S2/210A2/240A2 (LP)
		20049500B	20049500*	NPE-180S2/180A2 (NG)
		20050545A	20050545*	NPE-180S2/180A2 (LP)
		20029420B	20029420*	NPE-150S2 (NG)
		20034178A	20034178*	NPE-150S2 (LP)
13	Screw, S10A, M3x6, 3	-	20018065*	
14	Silence	-	20032570*	NPE-210S2/240S2/210A2/240A2
		-	20031242*	NPE-180S2/180A2
15	Silence Adapter	-	20032569*	NPE-210S2/240S2/210A2/240A2
		-	20049499*	NPE-180S2/180A2
14 & 15	Silence Assembly	30015142A	30015142*	NPE-210S2/240S2/210A2/240A2
		30024867A	30024867*	NPE-180S2/180A2
		30029081A	30029081*	NPE-150S2
16	Screw, S10A, 4x12	-	20006555*	
17	Screw, S18A, M4x10	-	20034293*	
18	Fan Packing	-	20022744*	
19	Reducer	-	30024970*	NPE-180S2/180A2

## 8.7 Installation Checklist

After installing the water heater, review the following checklist. You should be able to answer “Yes” to all of the items in the checklist. If not, review the appropriate sections to complete the installation. To troubleshoot any operational problems refer to “Troubleshooting” in the Owner’s Manual.

If you have additional questions or need assistance with installation, contact Technical Support at 1-800-519-8794 or 1-949-420-0420, or refer to the technical support section of Navien’s website ([www.navieninc.com](http://www.navieninc.com)).

Installing the Water Heater	Yes	No
Have you maintained the required clearances from building openings and intake air vents?		
Have you minimized the distance between the water heater and the vent termination?		
Have you minimized the distance between the water heater and major fixtures?		
Have you maintained the proper service and maintenance clearances?		
Is the make-up air supply sufficient for proper operation?		
Is the make-up air supply free from dust, dirt, corrosive elements, and flammable vapors?		
Is the water heater and vent piping clear of combustibile materials, including clothing, cleaning materials, and rags?		

Connecting the Gas Supply	Yes	No
Does the gas supply match the type specified on the water heater’s rating plate?		
Is the gas line at least 1/2 in. or 3/4 in. ID (Inner Diameter)?		
Is the gas supply line sufficient in length and diameter to deliver the required BTUs?		
Have you measured the pressure of the gas supply line?		
Is the gas supply pressure within the recommended ranges specified in this manual?		
Is the gas supply line equipped with a manual full port valve?		
Have you tested the gas line pressure and all fittings for leaks?		
Has the gas company inspected the installation, if required?		

Connecting the Water Supply	Yes	No
Is the water supply pressure sufficient (greater than 40 PSI)?		
Have you installed shut off valves on the inlet and outlet to facilitate cleaning of the inlet water filter?		
Have you bled the air out at each fixture?		
Have you checked each fixture to ensure hot water is being supplied?		
Have you cleaned the inlet water filter after operating the water heater for 10 minutes?		
If you installed a recirculation line, have you insulated the hot water pipes and the return line?		
Is the 2-way valve in the EXT position if a recirculation line is installed?		

Connecting a Pressure Relief Valve	Yes	No
Have you installed an approved pressure relief valve on the water heater?		
Does the rating of the pressure relief valve match or exceed the maximum BTU rating of the water heater?		
Is the pressure relief valve at least $\frac{3}{4}$ in. in diameter?		
Have you installed the pressure relief valve on the hot water outlet pipe near the water heater?		
Have you installed a discharge drain tube from the pressure relief valve to within 6–12 in. (150–300 mm) of the floor?		

Connecting the Condensate Drain	Yes	No
Have you installed a condensate drain line from the water heater to a suitable drain? Is the discharge point clearly visible?		
If a condensate pump is used, have you checked if it was operational?		

Venting the Water Heater	Yes	No
Have you vented the water heater with 2 in. or 3 in. PVC, CPVC, Polypropylene, Stainless Steel, UL-1738, Type BH Special Gas Vent (ULC-S636) for Category IV Water Heaters (Canada), or in accordance with all local codes and the guidelines in this manual?		
Have you ensured that PVC cellular core pipe has not been used as venting for the water heater?		
Is the vent sloped upward toward the vent termination at a rate of $\frac{1}{4}$ in. per foot (2 % grade)?		
Are all vent runs properly supported?		
Have you properly supported the vent termination?		
Have you properly sealed all air intake and exhaust joints, from the flue collar to the vent termination screens?		
Have you installed vent termination screens on the exhaust and intake pipes?		
Have you checked the venting for leaks?		
Is the vent termination at least 12 in. (300 mm) above the exterior grade?		
Have you ensured that sufficient make-up air is available?		
Is the total vent length within the maximum vent length restriction?		
Is there adequate clearance between the intake and exhaust termination?		

Connecting the Power Supply	Yes	No
Is the supplied voltage 110-120 V AC?		
Is the water heater plugged into a properly grounded outlet?		

Connecting the Power Supply	Yes	No
If you have made a direct power supply connection, have you installed a power switch to facilitate end-user maintenance?		
Have you checked the polarity of the electrical connection?		
Is the system properly set up for cascade operation (master and slave water heaters), if applicable?		

Setting with the Front Panel	Yes	No
Have you verified the desired settings using the front panel?		
Have you verified the parameters using the front panel?		

Operating the Water Heater	Yes	No
Have you shown the owner how to clean the inlet water filter?		
Have you given the Installation Manual and Owner's Manual to the owner for future reference?		
Have you shown the owner how to shut off the gas in case of an emergency?		

## 8.8 Navien H2Air Add-on Controller Kit (Optional)

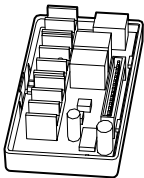

The Navien H2Air is an add-on controller for the Navien NPE-A2/S2 water heaters. It adds input and output functions to the NPE-A2/S2 water heaters for a combination application where space heating and domestic hot water (DHW) are supplied simultaneously. With this add-on controller, a thermostat (1 or 2-stage) and an outdoor sensor can be installed along with a hydronic air handler to add space heating functionality to the system.

**Note** This device is designed to work with the NPE-A2/S2 models ONLY.

### Basic Principles

The following diagram shows the basic operation of NPE-A2/S2 water heater system with the Navien H2Air add-on controller.

**Note** Do not configure the system for DHW recirculation when it is configured to run an air handler using the H2Air add-on controller. DHW recirculation and Navien H2Air configurations cannot be used at the same time.



## 8.9 AHU Application with RS-485 Communication (optional)

**Note**

- This application is designed to work with the single unit ONLY.
- The air handler must also be compatible with RS-485 communication features. Consult with the air handler manufacturer for additional guidelines and instructions.

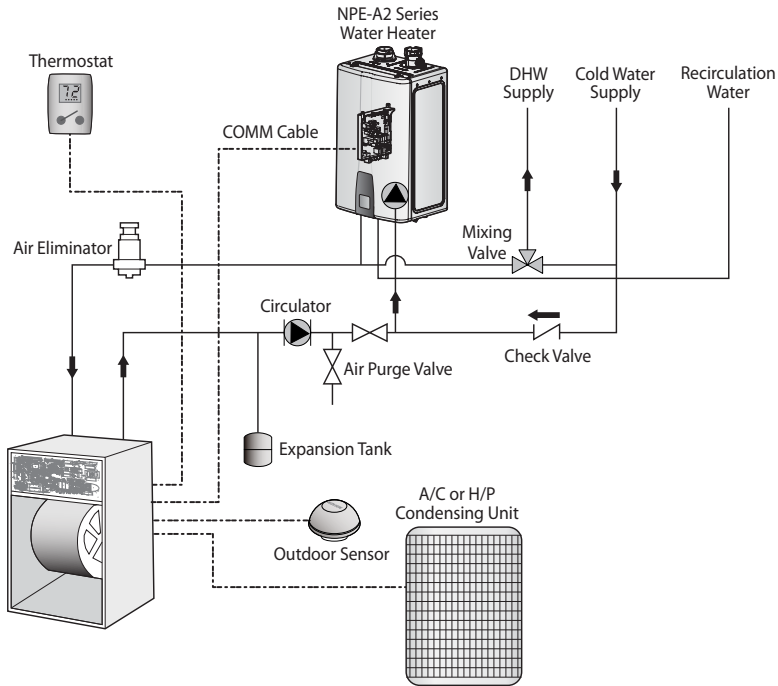

For details, contact the AHU manufacturer.

**Note**

System application drawings are intended to explain the system piping concept only. Refer to "7.5.1.3 Setting the Application" on page 101 for communication setting.

## 8.10 Requirements for the State of Massachusetts

### NOTICE BEFORE INSTALLATION

This appliance must be installed by a licensed plumber or gas fitter in accordance with the Massachusetts Plumbing and Fuel Gas Code 248 CMR Sections 4.00 and 5.00.

IMPORTANT: In the State of Massachusetts (248 CMR 4.00 & 5.00)

For all side wall horizontally vented gas fueled equipment installed in every dwelling, building or structure used in whole or in part for residential purposes, including those owned or operated by the Commonwealth and where the side wall exhaust vent termination is less than seven (7) feet above finished grade in the area of the venting, including but not limited to decks and porches, the following requirements shall be satisfied:

1. **INSTALLATION OF CARBON MONOXIDE DETECTORS.** No installation or replacement of a vented gas appliance shall be permitted unless a battery powered or electrically hard wired carbon monoxide detector is present on the same floor as the appliance or on the next adjacent floor when the appliance is located in a crawl space unless the appliance is located in a detached, uninhabitable garage. For all residential dwellings, a carbon monoxide detector must also be present on each habitable level of the dwelling. These requirements shall not be deemed to waive any additional requirements imposed by M.G.L. c. 148 §26F1/2.
2. **APPROVED CARBON MONOXIDE DETECTORS.** Each carbon monoxide detector as required in accordance with the above provisions shall comply with NFPA 720 and be ANSI/UL 2034 listed and IAS certified.
3. **SIGNAGE.** Whenever any through-the-wall vent is installed less than seven feet above the finished grade, a metal or plastic identification plate shall be permanently mounted to the exterior of the building at a minimum height of eight feet above grade directly in line with the exhaust vent terminal. The sign shall read, in print size no less than 0.5 inches in size, **"GAS VENT DIRECTLY BELOW. KEEP CLEAR OF ALL OBSTRUCTIONS"**.
4. **INSPECTION.** The state or local gas inspector of the side wall horizontally vented gas fueled equipment shall not approve the installation unless, upon inspection, the inspector observes carbon monoxide detectors and signage installed in accordance with the provisions of 248 CMR 5.09 and 5.12.

## 9. LIMITED WARRANTY NAVIEN, INC.

### Effective Terms

This 3-15 year limited warranty on heat exchangers, 3/5 year limited warranty on parts, and 1 year limited warranty on labor ("Warranty") covers defects in materials or workmanship when the Navien NPE-2 Water Heater ("Product") is installed by a properly licensed plumber or contractor and operated in strict compliance with the Installation & Operations manual procedures, subject to the terms within this Warranty document. Improper installation or use will void this Warranty. This Warranty runs from date of installation and extends to the original purchaser and subsequent owners, but only while the Product remains at the site of the original installation. This Warranty includes a limited warranty as set forth below.

### What is covered?

Subject to the foregoing terms, Navien will repair or replace the covered Product or any part or component that is defective in materials or workmanship for a period of five (5) years in regards to parts and up to fifteen (15) years in regard to the heat-exchanger for Standard<sup>1</sup> or Controlled-Recirculation<sup>2</sup> in a Single-Family Residential Application. Navien will pay labor charges for the repair subject to Navien's prior written approval and in accordance with Navien's schedule of approved labor allowances for a period of one (1) year from the date of installation. All repair parts must be genuine Navien parts. All repairs and replacements must be performed by an individual or servicing company that is properly licensed to do the type of repair.

When the Product is or has ever been used in an Uncontrolled-Recirculation<sup>3</sup> Single-Family residential application, the parts warranty will be reduced to three (3) years and the heat exchanger warranty will be reduced to five (5) years.

When the Product is or has ever been used in a Combi<sup>4</sup> or Commercial<sup>5</sup> application, using Standard<sup>1</sup> or Controlled-Recirculation<sup>2</sup>, then the heat exchanger warranty will be reduced to eight (8) years.

When the Product is or has ever been used in a Combi<sup>4</sup> or Commercial<sup>5</sup> application, using Uncontrolled-Recirculation<sup>3</sup>, then the parts and heat exchanger warranties will both be reduced to three (3) years.

During the applicable warranty period, replacement of the Product or components may be authorized by Navien only. Navien does not authorize any person or company to assume for it any obligation or liability in connection with the replacement of the Product or its components. If it is determined that repair or replacement of a part, under warranty, is not possible, the Product will be replaced with a new Product having at least the same BTU capacity as the product at issue. The replacement component or product will be warranted only for the unexpired portion of the applicable warranty period for the original component or Product.

### Applicable Warranty Periods

Application		Labor Warranty	Parts Warranty	Heat Exchanger Warranty
NPE-2 Series Water Heater (Residential)	Standard <sup>1</sup> or Cont-Recirc. <sup>2</sup>	1 year	5 years	15 years
	Uncont-Recirc <sup>3</sup>	1 year	3 years	5 years
NPE-2 Series Water Heater (Combi <sup>4</sup> or Commercial <sup>5</sup> )	Standard <sup>1</sup> or Cont-Recirc. <sup>2</sup>	1 year	5 years	8 years
	Uncont-Recirc <sup>3</sup>	1 year	3 years	3 years

<sup>1</sup>**Standard:** No recirculation through the water heater.

<sup>2</sup>**Controlled-Recirculation:** Recirculation through the water heater is controlled by either the water heater or an external aquastat. An aquastat is the minimum pump control requirement for DHW or storage tank controlled-recirculation.

<sup>3</sup>**Uncontrolled-Recirculation:** External pumps configured to circulate continuously through the water heater.

<sup>4</sup>**Combi:** When the Product is being used for domestic hot water ("DHW") and space heating.

<sup>5</sup>**Commercial:** Anything other than a Single-Family Residential Application.

### How do I get service?

You must contact the original installer of your Product. Your installer will need to contact Navien to report the issue. If the original installer cannot be identified or you no longer choose to use that service provider, you may choose any service provider who is properly licensed to complete the necessary repair. The installer and/or service provider must comply with Navien's warranty service and return policy procedures as available on Navien's website including contacting Navien's Technical Support Department at (800) 519-8794, option 2, prior to commencing any service.

Proof of the date of installation must be provided to Navien. At Navien's request, the defective Product or part must be returned to Navien. When the Product is installed in new construction, the date of installation shall be established as the date upon which the end-user takes title to the real property. If proof of the installation date is unavailable, then six months after the date of manufacture will be used.

Additional terms and conditions are continued on the reverse side.

Customer Name :	
Customer Address :	
Telephone :	Fax :
Email :	
Installer Name :	License No :
Installer Address :	
Place of Purchase :	
Model No :	
Serial No :	
Date of Purchase :	



### Navien, Inc.

20 Goodyear, Irvine, CA 92618  
Tel : 1-800-519-8794  
Fax : 949-420-0430  
www.navieninc.com

For instant warranty registration, please register your product online at [www.navieninc.com](http://www.navieninc.com)

## What is not covered?

Navien's Limited Warranty shall be void in the event of an occurrence of any of the following:

- Product purchased through the internet, other e-commerce channels, or any installer that obtained the Product from a supplier or distributor not authorized by Navien.
- Improper installation, failure to install in strict compliance with the Installation Manual procedures, installed by a non-licensed installer, and installation in violation of applicable rules, laws or building codes.
- Failure to perform regular maintenance, misuse, operation at settings other than those recommended or specified, non-compliance with instructions or guidelines set forth in the User's Operation Manual.
- Modification or alteration of the Product in any manner, including but not limited to, removal of any component or part, addition of any non-approved components, relocating or moving the Product from its original installation site, or any accidental or intentional damage to the Product.
- Installation for non-recommended uses.
- Any damage caused by local adverse conditions including but not limited to hard water deposits, lime or mineral build-up, operating in corrosive atmospheric elements.
- Damage or problems caused by gas flow issues, electrical surges, flooding, fire, abnormal external temperature, and any other cause of damage not directly caused by a manufacturing defect.
- Installer's failure to fully comply with the Warranty Service and Return Policy procedures previously provided to Installer and as is available on Navien's website. Such policies include but are not limited to the Installer's failure to first contact Navien Tech Support while in front of the product for purposes of trouble shooting the identified problem or issue.
- Use of the NPE-2 Series Water Heater for space heating only purposes shall void the warranty.
- Performance problems caused by improper sizing of the water heater, the gas supply line, the venting connection, combustion air openings, electric service voltage, wiring, fusing or any other components, parts or specifications.
- Improper conversion from natural gas to LP gas or LP gas to natural gas or attempt to operate with a type of gas not specified for the water heater.
- Any damage, malfunction or failure caused by abuse, negligence, alteration, accident, fire, flood, freezing, wind, lightning and other acts of God.
- Operating, using or storing the water heater in a corrosive or contaminated atmosphere or environment.
- Operating the water heater at water temperatures outside the factory calibrated temperature limits and/or exceeding the maximum setting of the high limit control.
- Operating the water heater when it is not supplied with potable water at all times.
- Subjecting the heat exchanger to pressures or firing rates greater or lesser than those shown on the rating plate.
- Installation at any location outside the United States and Canada.
- Removal or alteration of the rating plate.

## Warranty Limitations

EXCEPT AS EXPRESSLY PROVIDED HEREIN, THERE ARE NO OTHER WARRANTIES, EXPRESSED OR IMPLIED, INCLUDING, BUT NOT LIMITED TO WARRANTIES OR MERCHANTABILITY OR FITNESS FOR A PARTICULAR PURPOSE, WHICH EXTEND BEYOND THE DESCRIPTION OF THE WARRANTY HEREIN AND FURTHER NAVIEN SHALL NOT BE LIABLE FOR INDIRECT, INCIDENTAL, SPECIAL, CONSEQUENTIAL, PUNITIVE OR OTHER SIMILAR DAMAGES THAT MAY ARISE, INCLUDING LOST PROFITS, DAMAGE TO A PERSON OR PROPERTY, LOSS OF USE, INCONVENIENCE, OR LIABILITY ARISING FROM IMPROPER INSTALLATION, SERVICE OR USE OF THE PRODUCT. ANY IMPLIED WARRANTIES OF MERCHANTABILITY AND FITNESS ARISING UNDER STATE LAW ARE LIMITED IN DURATION TO THE PERIOD OF COVERAGE PROVIDED BY THIS WARRANTY, UNLESS THE PERIOD PROVIDED BY STATE LAW IS LESS.

No one is authorized to make any other warranties on behalf of Navien. Some states do not allow the exclusion or limitation of incidental or consequential damages, or how long an implied warranty lasts, so the above limitation may not apply to you.

This Limited Warranty gives you specific legal rights and you may also have other rights which vary from state to state.

Rev. 9.11.2023

Retain this document for future reference.



For instant warranty registration, please register your product online at [www.navieninc.com](http://www.navieninc.com)

# Notes

---

# Notes

---

# Installation Manual

## NPE Condensing Water Heaters

### Getting Service

If your water heater requires service:

- All repairs require pre-authorization by Technical Support.
- Request for your installer or any licensed professional to contact Technical Support at 1-800-519-8794 Option 2 once at the installation site.
- A short list of independent service providers in your area can be found on the website: [www.navieninc.com/installers](http://www.navieninc.com/installers).
- Contact a licensed professional for the affected system (for example, a plumber, gas fitter, or electrician).

When you contact Technical Support, please have the following information at hand:

- Model number
- Serial number
- Date purchased
- Installation location and type
- Error code, if any appears on the front panel display

Version: 2.0 (January, 2026)



Navien, Inc.  
800.519.8794 [www.navieninc.com](http://www.navieninc.com)  
20 Goodyear, Irvine, CA 92618